

A. Answer the following.

1. Use all the digits to make the greatest and the smallest possible six-digit numbers.

8, 5, 9, 6, 0, 1 Greatest possible number _____

Smallest possible number _____

2. Arrange in descending order – 43679851; 43680851; 43869851.
3. Write the number name for 8340392.

4. The expanded form of 359807 is

5. Put commas and write number name as per International System of place values for 79620356

B. Fill in the blanks.

1. The numeral for nine crore twenty-four lakh is _____.
2. The smallest 7-digit number is _____.
3. The greatest 8-digit number formed using the digits 0, 5, 8 and 9 is _____.
4. The predecessor of 48,11,000 is _____.
5. The successor of the smallest 8-digit number is _____.

C. Write as Hindu-Arabic numerals.

1. XXVII _____
2. LXI _____
3. CCLIX _____
4. CDXXXVIII _____

Teacher's Signature: _____

Remarks: _____

A. Put $>$, $<$ or $=$.

1. 7,23,143 seven lakh twenty-two thousand one hundred twenty-four
2. 2,46,714 two lakh twenty-seven thousand six hundred thirteen
3. 86,12,482 ninety-six lakh twelve thousand four hundred eighty-one
4. 41,341,333 thirty-one million three hundred forty-one thousand three hundred twenty-one

B. Round off the following numbers to the nearest 10.

1. 154 _____
2. 119 _____
3. 129 _____

C. Round off the following numbers to the nearest 100.

1. 8614 _____
2. 9376 _____
3. 3247 _____
4. 12,729 _____

D. Round off the following numbers to the nearest 1000.

1. 9212 _____
2. 28,584 _____
3. 65,955 _____
4. 5,12,700 _____

Teacher's Signature: _____

Remarks: _____

Worksheet 1

A. Solve.

- _____ - 100 = 9000
- _____ should be added to 9900 to get 10000.
- 72932 + _____ = 72932
- 7519 + 56720 + 38415 = _____ + 56720 + 7519

B. Write the missing digits.

1.

| | | | | | | |
|---|---|---|---|---|---|---|
| | 7 | □ | 3 | 4 | 7 | □ |
| - | □ | 2 | 3 | 2 | □ | 3 |
| | | | | | | |
| | 3 | 0 | 0 | 2 | 3 | 5 |

2.

| | | | | | | |
|---|---|---|---|---|---|---|
| | 7 | □ | 4 | 2 | 4 | □ |
| - | 4 | 3 | 2 | □ | 0 | 7 |
| | | | | | | |
| | 3 | 2 | □ | 2 | 4 | 0 |

3.

| | | | | | | |
|---|---|---|---|---|---|---|
| | 9 | 3 | □ | 6 | 5 | 5 |
| + | □ | 5 | 3 | □ | 1 | □ |
| | | | | | | |
| | 9 | □ | 7 | 9 | □ | 5 |

4.

| | | | | | | |
|---|---|---|---|---|---|---|
| | 5 | □ | 5 | □ | 3 | □ |
| + | □ | 0 | 2 | 3 | □ | 5 |
| | | | | | | |
| | 7 | 9 | □ | 8 | 9 | 8 |

C. Solve.

- ₹3,85,950 were given by the government to build a road in a town. The people of the town collected ₹65,175 more. How much money was available to build the road?

- A merchant had 36,555 sacks of wheat in his godown. On Sunday he sold 4,434 sacks and on Monday 3,999 sacks. How many sacks did he sell in all these two days? How many sacks were left?

Teacher's Signature: _____

Remarks: _____

Worksheet 2

A. Solve.

1. $6 + 36 + 3 - 3 \times 6 =$ _____
2. $64 - 8 \times 3 - 3 =$ _____
3. $19 \times 2 + 4 \div 2 =$ _____
4. $25 \times 0 - 0 \div 25 =$ _____

B. Solve.

1. $6 \times 2 + 7 =$ _____
2. $80 \div 8 - 3 =$ _____
3. $38 - 28 \div 7 =$ _____
4. $2 + 24 \div 2 \times 0 =$ _____

C. Solve.

1. How many apples are kept in 255 boxes, if each box contains 1,540 apples? _____
2. Jess exports 3,767 boxes of carrot seeds. What amount of money does he pay, if each box is priced at ₹455? _____
3. One box of toffees costs ₹590. What will be the cost of 42,100 such boxes? _____
4. Ritika deposits ₹5,555 every month. How much will she deposit in 36 months? _____
5. The cost of a suitcase is ₹2086. What will be the cost of 1,000 such suitcases? _____

Teacher's Signature: _____

Remarks: _____

A. What number am I?

1. I am the fifth multiple of 8. _____
2. I am a factor of all the numbers. _____
3. I am the smallest multiple of 12. _____
4. I am the greatest factor of 27. _____

B. Find the prime factors of the numbers.

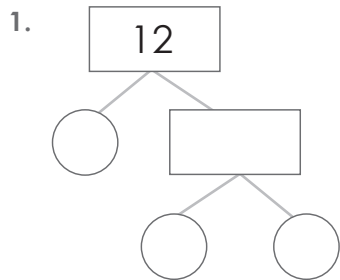

Prime factors:

$$12 = \underline{\quad} \times \underline{\quad} \times \underline{\quad}$$

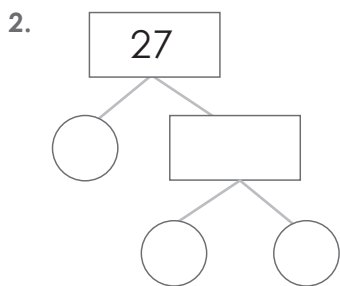

Prime factors:

$$27 = \underline{\quad} \times \underline{\quad} \times \underline{\quad}$$

C. Find the HCF using the prime factorisation method.

1. 28 and 40 _____
2. 38 and 54 _____
3. 55, 65 and 75 _____
4. 28, 48 and 70 _____

Teacher's Signature: _____

Remarks: _____

Worksheet 2

A. Check for divisibility. Tick (✓) the correct numbers.

- | | | | | | | |
|-------------------|-----|--------------------------|-----|--------------------------|-----|--------------------------|
| 1. Divisible by 5 | 260 | <input type="checkbox"/> | 417 | <input type="checkbox"/> | 323 | <input type="checkbox"/> |
| 2. Divisible by 3 | 450 | <input type="checkbox"/> | 138 | <input type="checkbox"/> | 226 | <input type="checkbox"/> |
| 3. Divisible by 9 | 457 | <input type="checkbox"/> | 513 | <input type="checkbox"/> | 900 | <input type="checkbox"/> |

B. Fill in the missing factors.

| | | | | | | | | |
|----|---|---|---|---|--|----|----|----|
| 12 | 1 | 2 | | 4 | | 12 | - | - |
| 18 | 1 | | 3 | | | | - | - |
| 30 | 1 | 2 | | 5 | | | 15 | |
| 40 | 1 | | 4 | 5 | | | | 40 |
| 63 | | 3 | | | | 63 | - | - |

C. Solve.

1. The product of two numbers is 600. The LCM is 120. Find the HCF.

2. The HCF and LCM of two numbers are 4 and 252, respectively. One of the numbers is 28, find the other number.

Worksheet 1

A. Write each fraction in its lowest form.

1. $\frac{5}{75}$ _____

2. $\frac{22}{42}$ _____

3. $\frac{17}{34}$ _____

4. $\frac{24}{36}$ _____

B. Write two equivalent fractions for each of the following fractions.

1. $\frac{4}{12}$ _____

2. $\frac{5}{40}$ _____

3. $\frac{3}{5}$ _____

4. $\frac{2}{3}$ _____

5. $\frac{1}{2}$ _____

C. Put >, < or = in the .

1. $\frac{5}{8}$  $\frac{7}{9}$

2. $\frac{6}{11}$  $\frac{5}{3}$

3. $\frac{9}{2}$  $\frac{18}{4}$

4. $\frac{3}{4}$  $\frac{5}{7}$

5. $\frac{8}{9}$  $\frac{4}{3}$

6. $\frac{7}{11}$  $\frac{11}{7}$

D. Solve.

1. $\frac{3}{6} - \frac{3}{10}$

2. $6 - 1\frac{1}{2}$

3. $\frac{3}{5} + \frac{2}{6}$

4. $\frac{8}{11} + \frac{3}{22}$

Teacher's Signature: _____

Remarks: _____

A. Find the equivalent fraction of $\frac{4}{5}$ with

1. denominator 20.
2. numerator 12.
3. denominator 25.

B. Arrange in ascending order.

1. $\frac{17}{27}$, $\frac{19}{27}$, $\frac{7}{27}$, $\frac{11}{27}$

2. $\frac{31}{7}$, $\frac{31}{23}$, $\frac{31}{29}$, $\frac{31}{13}$

C. Arrange in descending order.

1. $\frac{12}{13}$, $\frac{7}{13}$, $\frac{9}{13}$, $\frac{11}{13}$

2. $\frac{18}{7}$, $\frac{18}{5}$, $\frac{18}{13}$, $\frac{18}{17}$

A. Write the decimal and fractional expansion for the following.

| | | Decimal | Fractional |
|----|--------|---------|------------|
| 1. | 0.04 | | |
| 2. | 8.92 | | |
| 3. | 16.032 | | |
| 4. | 0.552 | | |
| 5. | 6.7 | | |

B. Convert the following unlike decimals into like decimals.

1. 2.02, 5.113, 7, 4.1

2. 25.1, 12.53, 2.2, 41.789

C. Arrange in columns and add/subtract.

1. $100.81 + 60.9$

2. $256 + 2002.7$

3. $74 - 28.02$

4. $194.05 - 45.9$

D. Solve

- The thickness of a book is 5.6 cm. What will be the total thickness of 25 such books?
- Ved runs a distance of 12.5 km in 5 rounds of the park. How much distance does he cover in 1 round?
- The cost of 8 bags is ₹10,450.44. Find the cost of each bag.

Teacher's Signature: _____

Remarks: _____

Worksheet 2**A. Build decimal numbers with**

1. 5 in the tens place, 1 in the ones place, 4 in the tenths place.

2. 8 in the ones place, 6 in the hundredths place.

3. 4 in the hundredths place, 3 in the thousandths place.

B. Write True or False.

1. 0.21 is equivalent to 0.210.

2. 2.200 is equivalent to 2.201.

3. 3.007 is equivalent to 3.0070.

4. 4.330 is equivalent to 4.335.

C. Arrange in ascending order.

1. 43.65, 43.56, 4.356, 435.6

2. 21.385, 213.85, 23.185, 281.35

D. Solve.

1. The height of one floor of a building is 10.25 m. What will be the height of 10 such floors?

2. Shallu distributed 6.4 kg of oranges equally between 4 families. How many kg will each family get?

3. A packet of juice holds 1.75 l of juice. How much juice will 22 such packets hold?

Teacher's Signature: _____

Remarks: _____

Worksheet 1

A. Convert to a fraction.

- | | | |
|--------|--------|--------|
| 1. 43% | 2. 34% | 3. 72% |
| 4. 63% | 5. 9% | 6. 27% |

B. Write the fraction for the coloured parts of each figure. Convert the fraction to a percentage.

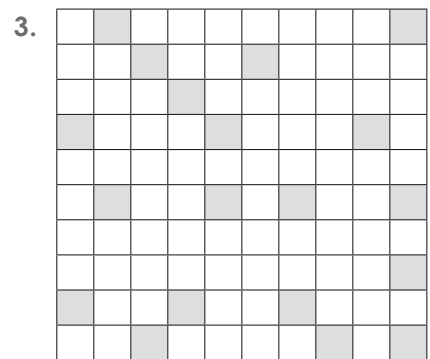
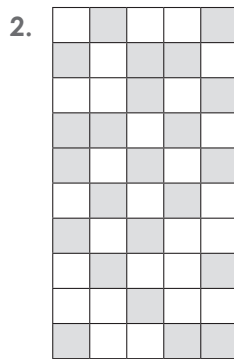
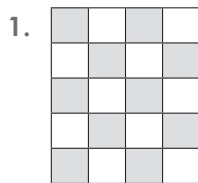

Fraction = _____ Fraction = _____ Fraction = _____

Percentage = _____ Percentage = _____ Percentage = _____

C. Convert to a percentage.

- | | | |
|----------|----------|---------|
| 1. 0.93 | 2. 4.92 | 3. 6.83 |
| 4. 29.45 | 5. 48.64 | 6. 0.08 |

D. Find.

- | | | |
|---------------|----------------|---------------|
| 1. 20% of 500 | 2. 5% of 720 | 3. 50% of 400 |
| 4. 40% of 190 | 5. 100% of 320 | 6. 30% of 620 |

Teacher's Signature: _____

Remarks: _____

Worksheet 2**A. Find the value of the following percentages.**

1. 25% of 200 days
2. 20% of 285 pages
3. $4\frac{1}{4}$ % of 360 m
4. 12% of 60 l
5. $3\frac{1}{3}$ % of 180 km
6. 60% of 90 kg

B. What per cent is each of the following?

1. 1.5 g of 60 g
2. 0.5 m of 50 m
3. 45 hours of 150 hours
4. 120 p of ₹1
5. 1.5 l of 30 l
6. $3\frac{1}{2}$ kg of 10 kg

C. Solve the word problems.

1. Out of 50 students in the class, 20 students performed in dramatics. What percentage of students did not particulate in dramatics?
2. $\frac{4}{5}$ of the farmers grow wheat in their fields. What per cent of the farmers grow wheat?
3. 65% of 4280 students in a school are girls. How many girls are there in the school?

Worksheet 1

A. Identify the type of angle formed by the hands of the clock.

1.



2.



3.



4.



B. Draw the following angles using a protractor. Use a compass and a ruler to bisect each angle.

1. $\angle ABC = 80^\circ$

2. $\angle MNO = 120^\circ$

C. Fill in the blanks.

1. _____ is a fixed point in the circle.
2. A line segment from the centre to any point on the circle is called the _____
3. The chord that passes through the centre of the circle is called the _____
4. The perimeter or boundary of the circle is called its _____
5. The diameter of a circle divides it into two equal parts. Each part is called a _____

Teacher's Signature: _____

Remarks: _____

Worksheet 2

A. Fill in the blanks.

1. Lines which cross each other at a point are called _____ lines.
2. Lines in a plane that never meet and are always at an equal distance from each other are called _____ lines.
3. Two lines that intersect at right angles are called _____ lines.
4. Two angles whose sum equals 180° are called _____
5. To measure angles, we use an instrument called a _____

B. Draw the following angles using a protractor.

- | | |
|----------------|---------------|
| 1. 60° | 2. 90° |
| 3. 120° | 4. 30° |

C. Find the diameters of the circles whose radii are the following.

- | | | |
|-----------|-----------|-------------------|
| 1. 4.5 cm | 2. 7.8 cm | 3. $3\frac{1}{2}$ |
| _____ | _____ | _____ |

D. Find the radii of the circles whose diameters are the following.

- | | | |
|----------|-----------|---------|
| 1. 10 cm | 2. 8.8 cm | 3. 9 cm |
| _____ | _____ | _____ |

Teacher's Signature: _____

Remarks: _____

Worksheet 1

A. Tick (✓) the word that looks the same after a half turn.

1. NOON

2. HOME

3. SOON

4. MOM

5. COME

6. SIS

B. Colour the views to match the colours in the figure.

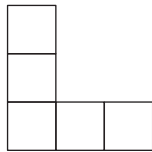
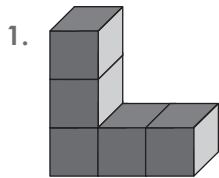

Front view

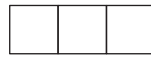

Top view

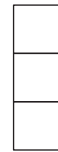

Side view

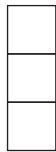
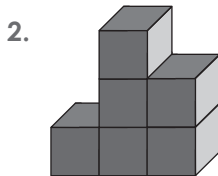

Side view

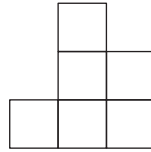

Front view



Top view

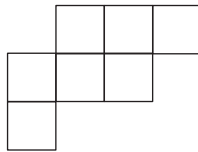
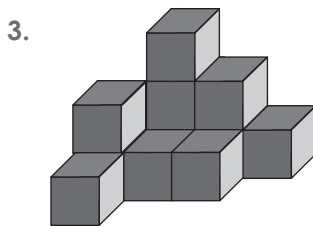

Top view

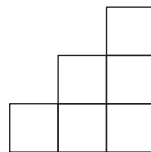

Side view

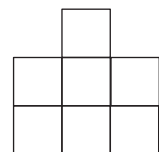

Front view

C. Draw a line of symmetry through the given letters.

1. C

2. M

3. O

4. H

5. M

Teacher's Signature: _____

Remarks: _____

Worksheet 2

A. How would the following shapes look on quarter turn and half turn?

| | SHAPE | ON $\frac{1}{4}$ TURN | ON $\frac{1}{2}$ TURN |
|----|-------|-----------------------|-----------------------|
| 1. | | | |
| 2. | | | |
| 3. | | | |
| 4. | | | |
| 5. | | | |

B. Identify which view.

1.
 ___ view ___ view ___ view

2.
 ___ view ___ view ___ view

3.
 ___ view ___ view ___ view

Teacher's Signature: _____

Remarks: _____

A. Find the selling price.

| | COST PRICE | PROFIT/LOSS | SELLING PRICE |
|----|------------|--------------|---------------|
| 1. | ₹90 | Profit = ₹17 | |
| 2. | ₹390 | Profit = ₹35 | |
| 3. | ₹185 | Loss = ₹25 | |
| 4. | ₹880 | Loss = ₹90 | |
| 5. | ₹1350 | Loss = ₹135 | |

B. Find the profit %.

1. $SP = ₹780, CP = ₹650$

2. $SP = ₹550, CP = ₹500$

3. $CP = ₹400, SP = ₹750$

4. $CP = ₹2500, SP = ₹2700$

C. Find the loss %.

1. $SP = ₹1200, CP = ₹1500$

2. $SP = ₹4400, CP = ₹5500$

3. $CP = ₹1000, SP = ₹750$

4. $CP = ₹3400, SP = ₹1700$

Teacher's Signature: _____

Remarks: _____

Worksheet 2

Vishal went to a nearby shop to make some purchase. Study the given bill for the items purchased by him and answer the following questions.

| ITEMS | | QUANTITY (QTY) | RATE (in ₹) | AMOUNT (in ₹) |
|-------|--------------|----------------|-------------|---------------|
| 1. | Cardboard | 5 | 25 | 125 |
| 2. | Pen | 6 | 20 | 120 |
| 3. | Notebook | 10 | 15 | 150 |
| 4. | Colour box | 2 | 75 | 150 |
| 5. | Pencil box | 5 | 30 | 150 |
| | Total | 28 | | 695 |

1. What kind of shop is this? _____
2. Which place did Vishal go for the purchase? _____
3. What were the items purchased? _____
4. How many items did Vishal purchase? _____
5. How many colour boxes were purchased? _____
6. How much did Vishal pay for the cardboard? _____
7. What was the date of purchase? _____
8. What was the total amount paid by Vishal for the bill? _____

Teacher's Signature: _____

Remarks: _____

Worksheet 1

A. Read the given map. Study the legend and answer the questions.

1. Label the road as M.G. Road
2. Colour the park green
3. What lies opposite the supermarket on the other side of the road?

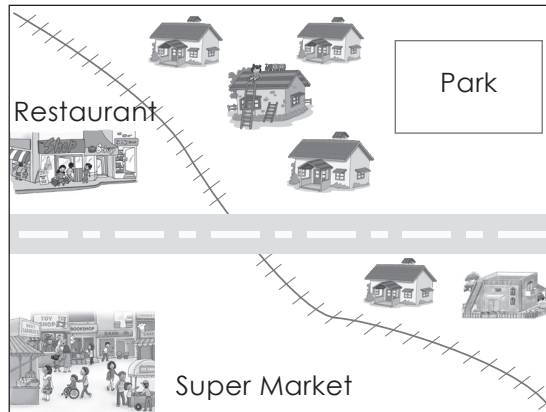

- | | |
|--|---------------|
| | Park |
| | House |
| | Super Market |
| | Restaurant |
| | Railway track |
| | Road |

4. What symbol is used to represent the Railway track?

B. Use a scale to join the dots. Measure the length with a cm scale.

Answer the questions. Scale 1 cm on map = 2 km

1. How far is the car showroom from the school?
On the map = 2.3 cm
On the ground = ____ km
2. How far is the football field from the school?
On the map = 4.3 cm
On the ground = ____ km

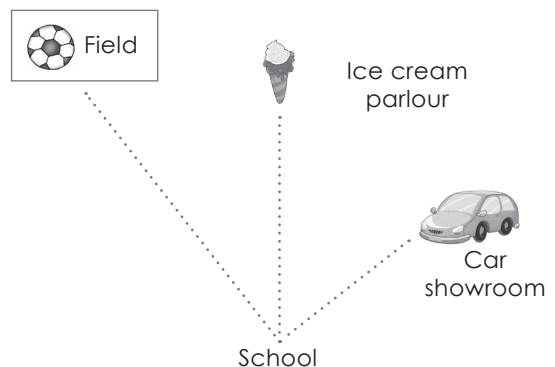

3. To go from school to the ice cream parlour, in which direction do we move?

Teacher's Signature: _____

Remarks: _____

Worksheet 2

A. Tick (✓) the correct option. The scale of the map is 1 cm = 300 km.

1. If the distance between City A and City B on the map is 3.3 cm, the distance on the ground is

- | | | | |
|------------|--------------------------|------------|--------------------------|
| a. 9900 cm | <input type="checkbox"/> | b. 990 cm | <input type="checkbox"/> |
| c. 990 km | <input type="checkbox"/> | d. 9900 km | <input type="checkbox"/> |

2. If the distance between City B and City C is 8100 km, the distance on the map is

- | | | | |
|-----------|--------------------------|-----------|--------------------------|
| a. 27 km | <input type="checkbox"/> | b. 27 cm | <input type="checkbox"/> |
| c. 270 cm | <input type="checkbox"/> | d. 270 km | <input type="checkbox"/> |

B. Find the direction of each with respect to the girl.

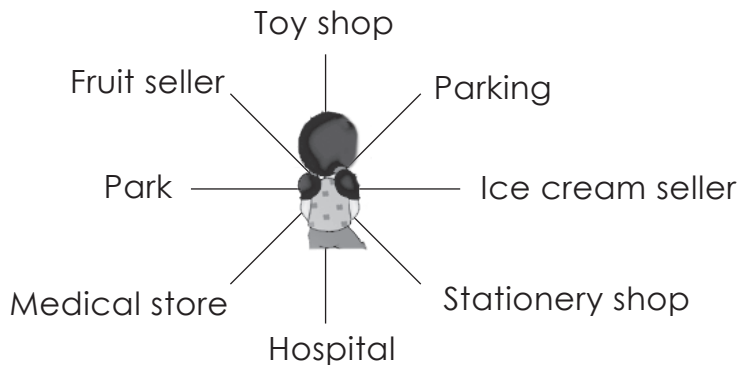

- The stationery shop is in the _____
- The ice cream seller is in the _____
- The medical store is in the _____
- The hospital is in the _____
- The parking is in the _____

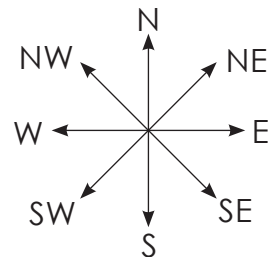

Teacher's Signature: _____

Remarks: _____

Worksheet 1

A. Write each time in 24-hour clock.

1. 5:15 a.m. _____
2. 1:00 a.m. _____
3. 12:00 midnight _____
4. 10:30 p.m. _____
5. 12:30 a.m. _____
6. 12:45 p.m. _____
7. 8:05 p.m. _____
8. 7:20 a.m. _____

B. Find the sums.

1. 6 h 40 min + 4 h 50 min

2. 4 years 6 months + 6 years 7 months

C. Find the difference.

1. 6 h 35 min 55 sec – 4 h 25 min 33 sec

2. 8 h 25 min 10 sec – 3 h 25 min 40 sec

D. Multiply.

1. 7 weeks 4 days by 8

2. 5 weeks 3 days 20 hours by 8

E. Divide.

1. 10 weeks 5 days by 5

2. 25 weeks 6 days 12 hours by 6

Teacher's Signature: _____

Remarks: _____

Worksheet 2

A. Read the time on each clock and answer these questions.

1.



What will be the time after 35 minutes?

2.



What was the time 1 hour 15 minutes before?

3.



What will be the time after 2 hours 5 minutes?

4.



What will be the time after 6 hours 20 minutes?

B. Fill in the table.

| | Starting date | Duration | Finishing date |
|----|---------------|----------|----------------|
| 1. | 11 December | | 25 December |
| 2. | | 11 days | 11 June |
| 3. | 15 November | | 15 December |
| 4. | | 15 days | 31 August |
| 5. | 5 April | | 1 May |

Teacher's Signature: _____

Remarks: _____

A. Complete the table.

| | MEASUREMENT | IN BIGGER UNITS | IN SMALLER UNITS |
|----|-------------|-----------------|------------------|
| 1. | 9 m 40 cm | 9.40 m | 940 cm |
| 2. | | 8.900 kg | |
| 3. | | | 750 ml |
| 4. | 5 l 426 ml | | |
| 5. | 4 m 23 cm | | |
| 6. | | 2.825 l | |
| 7. | | | 5056 g |
| 8. | 23 kg 120 g | | 23120 g |

B. Multiply.

1. 26 m 8 cm by 11

2. 12 kg 675 g by 34

C. Divide.

1. 15 l 245 ml by 5

2. 15 m 39 cm by 9

D. Convert the following into smaller units.

1. 8.01 litres into

a. decilitres

b. centilitres

c. millilitres

2. 408 kilograms into

a. hectograms

b. decagrams

c. grams

Teacher's Signature: _____

Remarks: _____

A. Tick (✓) the correct option.

1. 2 cm 9 mm = _____ mm

a. 209

b. 29

c. 290

2. 3 kg 500 g = _____ kg

a. 3500

b. 3.5

c. 3050

3. 9 l = _____ ml

a. 9000

b. 900

c. 90

4. 3 km 228 m = _____ km

a. 3.228

b. 3228

c. 32280

5. 7 l 125 ml = _____ l

a. 7.125

b. 71.25

c. 71.250

B. Solve the word problems.

1. Parth walked 5.678 km on Monday and 7.897 km on Tuesday. Find the total distance he has walked on both the days.
2. A tank can hold 300 l 250 ml. If it has 298 l 234 ml, how much more water can be filled in it?
3. The cost of 1 kg of cherries is ₹175. Find the cost of 6 kg 250 g of cherries.
4. 27 l 30 ml of juice was divided equally among 3 friends. How much did each friend get?

Teacher's Signature: _____

Remarks: _____

Worksheet 1

A. Fill in the table.

| LENGTH OF THE RECTANGLE | BREADTH OF THE RECTANGLE | PERIMETER OF THE RECTANGLE |
|-------------------------|--------------------------|----------------------------|
| 9 cm | 7 cm | |
| 40 km | 8 km | |
| 26 m | 3 m | |

B. Find the area of each of the following figures.

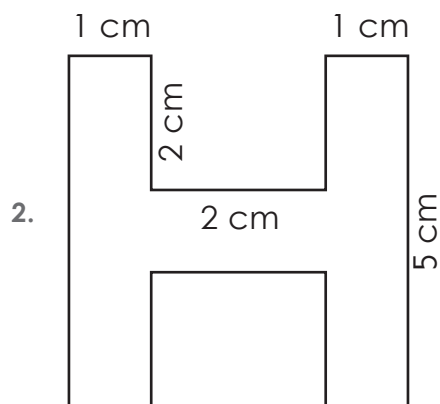
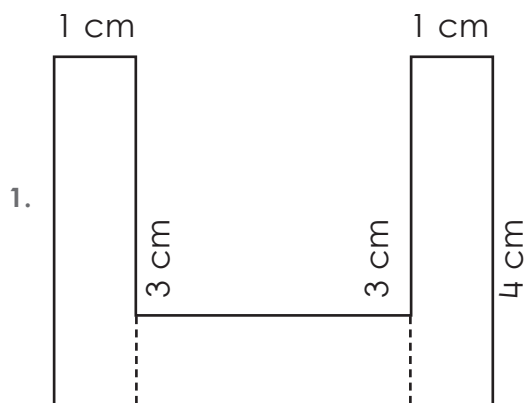

C. Find the volume of these objects.

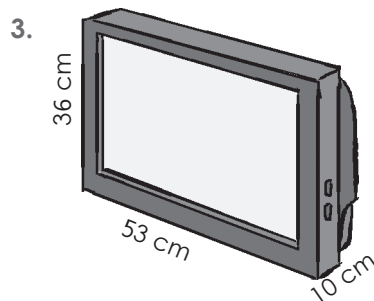
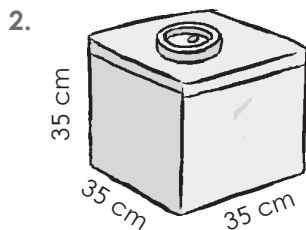
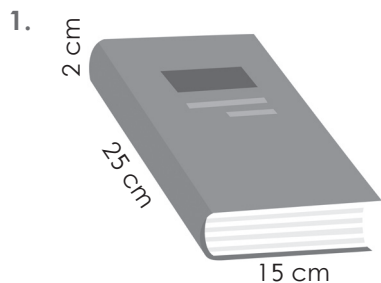

Teacher's Signature: _____

Remarks: _____

Worksheet 2

A. Find the area of a square whose perimeter is as given below.

1. 64 cm
2. 102 cm

B. Calculate the area of these shapes in square units. The side of each square is 1 unit.

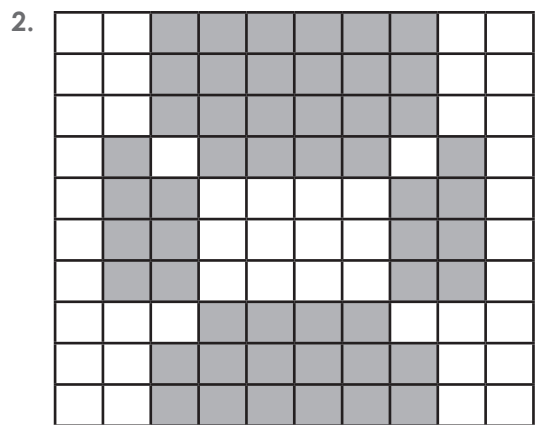
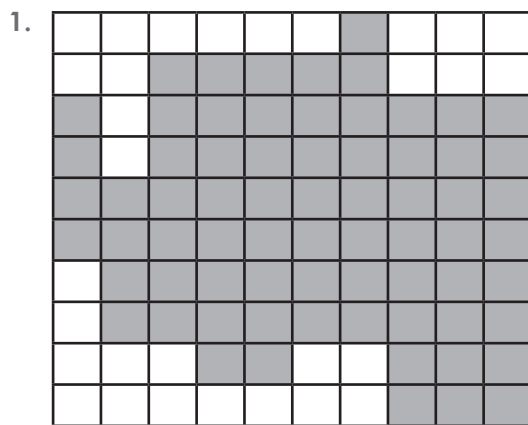

C. Find the volume for each of the objects given below.



length = 15 m
 width = 6 m
 height = 2 m
 volume = _____



length = 10 cm
 width = 9 cm
 height = 30 cm
 volume = _____

Teacher's Signature: _____

Remarks: _____

Worksheet 1

The given chart shows the number of visitors that an amusement park had over the course of a year.

1. In which month did the amusement park receive the most visitors?

2. How many visitors came to the park that month?

3. Why do you think so many visitors came during that month?

4. How many visitors, in total, came to the park during September, October and November?

5. Describe the pattern you see in the number of visitors from April to November.

6. What might explain no visits to the park during February and March?

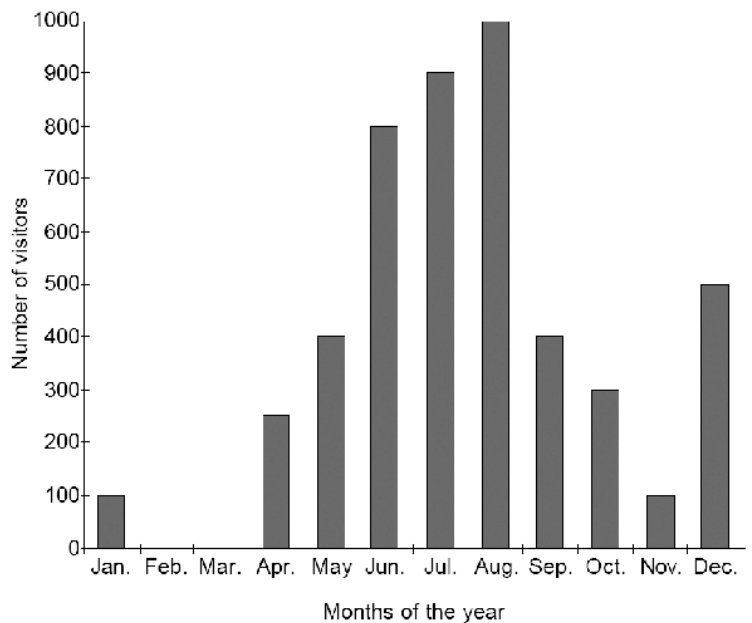

Teacher's Signature: _____

Remarks: _____

The line graph shows the number of students in various houses of Class V. Read the line graph and answer these questions.

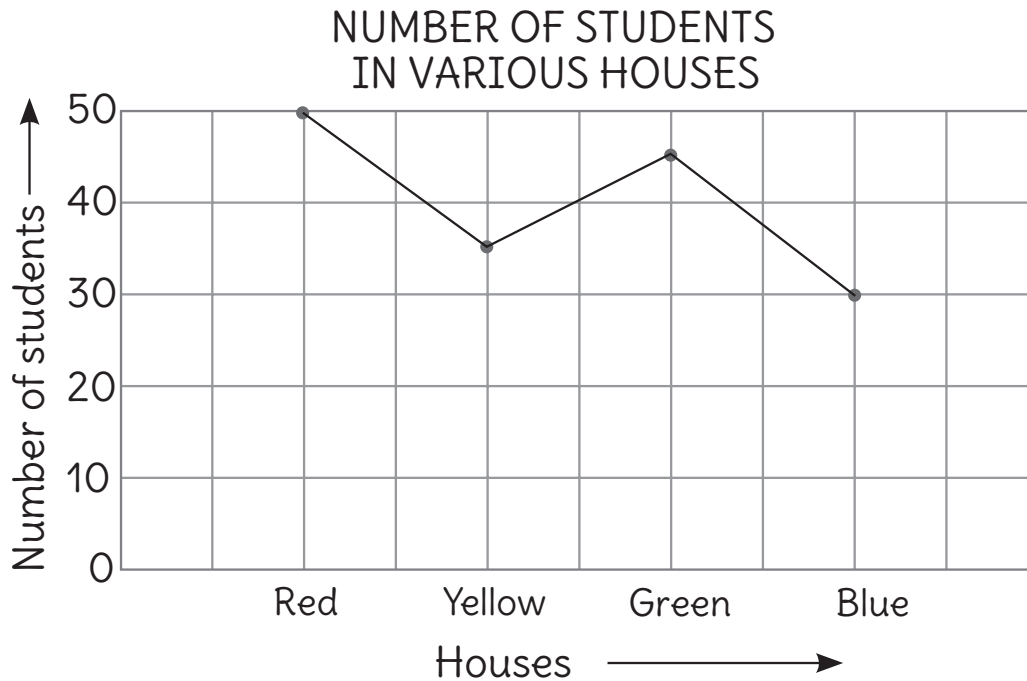

1. Which house has the minimum students? _____
2. How many students are there in the Green house? _____
3. How many more students are there in the Green house than the Blue house? _____
4. How many less students are there in the Yellow house than in the Red house? _____

Teacher's Signature: _____

Remarks: _____