

TEACHER'S HANDBOOK



STELLAR LEARNING

Physics

10

On
Board!

BOOKS

An imprint of Ratna Sagar P. Ltd.

Contents

10. Light – Reflection and Refraction	5
11. The Human Eye and the Colourful World	33
12. Electricity	46
13. Magnetic Effects of Electric Current	63
14. Sources of Energy	77

Light – Reflection and Refraction

Checkpoint _____ (Page 6)

- Objects like the sun that emit light of their own are called
 - radioactive objects.
 - luminous objects.
 - reflector objects.
 - primary objects.

Ans. The correct answer is (b).

- How many laws of reflection are there?

(a) 4	(b) 3
(c) 2	(d) 1

Ans. The correct answer is (c).

- The angle of incidence is
 - the angle that the incident ray makes with the mirror.
 - the angle that the incident ray makes with the normal at the point of incidence.
 - 180° minus the angle that the incident ray makes with the mirror.
 - the angle that the incident ray makes with the reflected ray.

Ans. The correct answer is (b).

- The image formed by a plane mirror is
 - virtual, erect, behind the mirror and smaller than the object.
 - virtual, erect, behind the mirror and the same size as the object.
 - virtual, inverted, behind the mirror and the same size as the object.
 - real, erect, behind the mirror and the same size as the object.

Ans. The correct answer is (b).

- If the angle between the mirror and the incident ray is 30°, the angle of reflection is

- | | |
|---------|---------|
| (a) 30° | (b) 60° |
| (c) 15° | (d) 90° |

Ans. If the angle between the mirror and the incident ray is 30°, the angle between the incident ray and the normal is $90^\circ - 30^\circ = 60^\circ$. This is the angle of incidence. Since the angle of incidence = angle of reflection, the correct answer is (b).

- Two plane mirrors are kept at the following angles one by one. In which case is the number of images formed the maximum?

- | | |
|---------|---------|
| (a) 30° | (b) 60° |
| (c) 45° | (d) 90° |

Ans. The formula for the number of images formed when two plane mirrors are kept at an angle n° is

$$\text{No. of images} = \left(\frac{360^\circ}{n^\circ} \right).$$

If the number calculated is even, you subtract 1 from it.

Thus, the lower the value of n , the higher is the number of images formed.

Therefore, the correct answer is (a).

- Fill in the blanks:** An image that can be obtained on a screen is called a image, while one that cannot be obtained on a screen is called a image.

Ans. An image that can be obtained on a screen is called a real image, while one that cannot be obtained on a screen is called a virtual image.

- If you have a mole on your right cheek, on which cheek will the mole appear to be in your image in a plane mirror?

Ans. Since the image formed by a plane mirror is laterally inverted, the mole will appear on the left cheek in the image.

9. The image given below shows the reflection of a ray of light from a plane mirror kept horizontal on the ground. What is the measure of angle A in the figure?

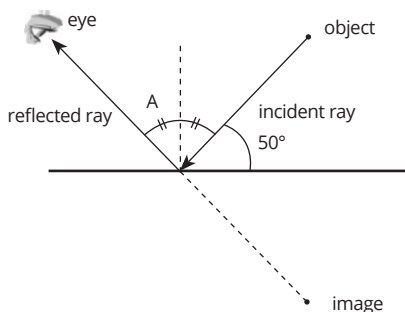

Ans. The angle made by the incident ray with the mirror is 50° . Therefore, the angle made by the incident ray with the normal is $90^\circ - 50^\circ = 40^\circ$. This is the angle of incidence, which is equal to A, the angle of reflection. Therefore, $A = 40^\circ$.

10. In a kaleidoscope, the mirrors make an angle of with each other.

Ans. In a kaleidoscope, the mirrors make an angle of 60° with each other.

(I) REFLECTION OF LIGHT

Milestone

(Page 16)

Multiple-Choice Questions

1. The angle of incidence is the angle between
- the normal to the mirror surface and the incident ray.
 - the normal to the mirror surface and the mirror surface.
 - the incident ray and the mirror surface.
 - the reflected ray and the mirror surface.

Ans. The correct answer is (a).

2. In this set of 26 capital letters of the English alphabet, the number of those which will appear the same in a plane mirror are

A B C D E F G H I
J K L M N O P Q R
S T U V W X Y Z

- 7.
- 9.
- 11.
- 13.

Ans. We have to mark out those letters that will look the same from left to right and from right to left, i.e. which remain the same in case of lateral inversion. These letters are A, H, I, M, O, T, U, V, W, X, and Y. Therefore, the correct answer is (c).

3. A concave mirror is distinguished from a convex mirror using the property of
- convergence.
 - divergence.
 - magnification.
 - none of these.

Ans. A concave mirror is a converging mirror. Therefore, the correct answer is (a).

4. $f = \frac{R}{2}$ is valid

- for convex mirrors but not concave mirrors.
- for concave mirrors but not convex mirrors.
- for both convex and concave mirrors.
- for neither convex nor concave mirrors.

Ans. The correct answer is (c).

5. An object is placed at the centre of curvature of a concave mirror. The distance between its image and the pole is

- equal to f .
- between f and $2f$.
- equal to $2f$.
- greater than $2f$.

Ans. The image is also formed at the centre of curvature in this case. Therefore, the correct answer is (c).

6. The magnification of an image formed by a spherical mirror is negative. It means that the image is

- smaller than the object.
- larger than the object.
- erect.
- inverted.

Ans. The correct answer is (d).

7. A point object is placed on the principal axis of a spherical mirror. The object distance is

- definitely negative.
- definitely positive.
- positive if the object is to the left of the centre of curvature.
- positive if the object is to the right of the centre of curvature.

Ans. According to the sign convention for mirrors, the object distance is always negative. Therefore, the correct answer is (a).

8. A ray of light is incident on a concave mirror. If it is parallel to the principal axis, the reflected ray will

- pass through the focus.
- pass through the centre of curvature.
- pass through the pole.
- retrace its path.

Ans. The correct answer is (a).

9. Nature of the image is not affected by the position of object in a
- (a) plane mirror. (b) concave mirror.
(c) convex mirror. (d) none of these.

Ans. The correct answer is (a).

Very Short Answer Type Questions

10. If an object is placed at a distance of 5 cm in front of a plane mirror, how far away will it be from its image?
- Ans.** Image distance is the same as the object distance in a plane mirror. Therefore, distance of the image from the mirror is 5 cm and the distance from the object is 10 cm.
11. What is lateral inversion?
- Ans.** Lateral inversion is the phenomenon because of which the left of an object appears to be right and right appears to be left in an image in a plane mirror.
12. What happens when a ray of light falls normally on the surface of a mirror?
- Ans.** It reflects back along the same direction.
13. What is the focal length for a plane mirror?
- Ans.** The focal length for a plane mirror is infinity.
14. In which kind of mirrors – plane, concave or convex – can you get a virtual image of an object placed in front of it?
- Ans.** It is possible to get a virtual image in case of all three mirrors.
15. A mirror has a focal length of +10 cm. Is it convex or concave?
- Ans.** According to the sign convention, if the focal length has a positive sign, it is a convex mirror.
16. Which side of a spoon can be approximated to a concave mirror and which side to convex mirror?
- Ans.** The front side which is used to scoop up food is concave and the side behind it is convex.
17. If the sum of focal length and radius of curvature of a spherical mirror is 30 cm, what is the focal length of the mirror?
- Ans.** If focal length is f , then radius of curvature is $2f$. Therefore, $f + 2f = 30$ cm gives $f = 10$ cm.

Short Answer Type-I Questions

18. If we hold a cardboard in front of us while facing a plane mirror, why can we not see our face?
- Ans.** This is because the light that falls on the cardboard gets reflected in all directions irregularly.
19. The angle between an incident ray and the surface of the plane mirror is 40° . What is the
- (a) angle of incidence and

(b) angle of reflection?

Ans. (a) Angle of incidence = $90^\circ - 40^\circ = 50^\circ$.

(b) Angle of reflection = angle of incidence = 50°

20. What is the difference between a ray of light and a beam of light?

Ans. The direction or path along which light travels in a medium is called a ray of light. It is represented by a straight line. A group of light rays is called a beam of light.

21. Distinguish between the focus of a concave mirror and a convex mirror.

Ans. The focus of a concave mirror lies in front of the mirror and is a real focus because light rays actually converge at the focus after reflection from the concave mirror. The focus of a convex mirror lies behind the mirror and is a virtual focus because light rays appear to come from the focus after reflection from a convex mirror.

22. Draw a ray diagram to show the path of the reflected ray corresponding to an incident ray that is directed towards the principal focus of a convex mirror. Mark on it the angle of incidence and the angle of reflection.

Ans.

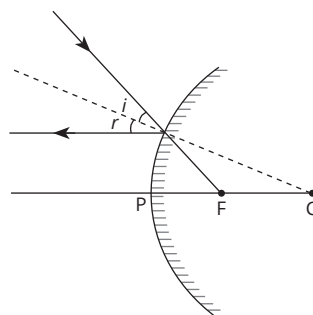

23. According to the New Cartesian Sign Convention for mirrors, what sign has been given to the following:

- (a) Height of inverted and real image
(b) Focal length of convex mirror

Ans. (a) Negative

(b) Positive

24. An object is placed 20 cm from a convex mirror. Its image is formed 12 cm from the mirror. Find the focal length of the mirror.

Ans. Given, $u = -20$ cm, $v = 12$ cm

Using the mirror formula,

$$\frac{1}{f} = \frac{1}{12} + \frac{1}{(-20)} = \frac{1}{30}$$

Therefore, the focal length is 30 cm.

25. The image of an object placed 16 cm from a concave mirror is formed at a distance of 24 cm from the

mirror. Calculate the possible focal lengths of the concave mirror from this information.

Ans. Given, $u = -16$ cm; v can be $+24$ cm or -24 cm

For $v = +24$ cm,

$$\frac{1}{f} = \frac{1}{24} + \frac{1}{(-16)} = \frac{-1}{48}$$

or $f = -48$ cm

For $v = -24$ cm,

$$\frac{1}{f} = \frac{1}{(-24)} + \frac{1}{(-16)} = \frac{-5}{48}$$

or $f = -9.6$ cm

Short Answer Type-II Questions

26. List any four characteristics of the image formed by a plane mirror.

Ans. (a) The image is formed behind the mirror and has the same size as the object.

(b) The image is laterally inverted.

(c) The image is virtual.

(d) The image is erect.

27. Define the following terms:

(a) Luminous objects (b) Diffused reflection

(c) Real image (d) Point of incidence

Ans. (a) Objects that emit light of their own are called luminous objects.

(b) Diffused reflection is the reflection of light or other waves or particles from a surface such that a ray incident on the surface is scattered at many angles rather than at just one angle.

(c) An image that can be obtained on a screen is called a real image.

(d) The point at which the incident ray of light strikes the reflecting surface of a mirror is called the point of incidence.

28. When a concave mirror is placed facing the sun, the sun's rays converge to a point 10 cm from the mirror. Now, an erect, 2 cm long pin is placed 15 cm away on the principal axis of the mirror. If you want to get the image of the pin on the card, where would you place the card? What would be the nature and height of the image?

Ans. Based on the information given, the focal length of the concave mirror, $f = -10$ cm

$u = -15$ cm, $h = 2$ cm

Using mirror formula,

$$\frac{1}{(-10)} = \frac{1}{v} + \frac{1}{-15}$$

or $v = -30$ cm

$$\frac{-v}{u} = \frac{h'}{h}$$

or $h' = \frac{-v \times h}{u} = \frac{30 \times 2}{-15} = -4$ cm

Therefore, the card should be held 30 cm from the mirror on the same side as the object. The image formed is a real and inverted image of height 4 cm.

29. An object is placed at a distance 12 cm from a convex mirror of radius of curvature 12 cm. Find the position of the image. If the height of the object is 1.2 cm, what will be the height of the image?

Ans. Radius of curvature of the convex mirror = 12 cm; therefore, focal length = 6 cm

$u = -12$ cm, $h = 1.2$ cm

Using mirror formula,

$$\frac{1}{6} = \frac{1}{v} + \frac{1}{-12}$$

or $v = 4$ cm

$$\frac{-v}{u} = \frac{h'}{h}$$

or $h' = \frac{-v \times h}{u} = \frac{-4 \times 1.2}{-12} = 0.4$ cm

Therefore, the image is formed 4 cm behind the mirror and is 0.4 cm in height.

30. An object is placed 24 cm from a concave mirror. Its image is inverted and twice the size of the object. Find the focal length of the mirror and the position of the image formed.

Ans. $u = -24$ cm, $m = -2$

We know that, $m = \frac{-v}{u}$

or $-2 = \frac{-v}{-24}$

or $v = -48$ cm

Using mirror formula,

$$\frac{1}{f} = \frac{1}{-48} + \frac{1}{-24} = \frac{-1}{16}$$

or $f = -16$ cm

Long Answer Type Questions

31. Distinguish between regular and irregular reflection.

Ans. In regular reflection, a parallel beam of light incident on a smooth and polished surface gets reflected along the same direction in the form of a parallel beam of light. In irregular reflection, a parallel beam of light incident on a rough surface gets reflected along different directions.

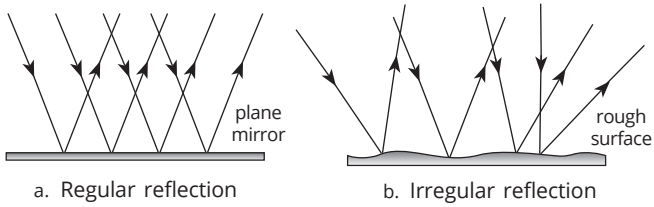

32. Draw ray diagrams showing the image formation by a concave mirror when an object is placed:
- between pole and focus of the mirror,
 - between focus and centre of curvature of the mirror,
 - at the centre of curvature of the mirror, a little beyond centre of curvature of the mirror, and
 - at infinity.

Ans. (a)

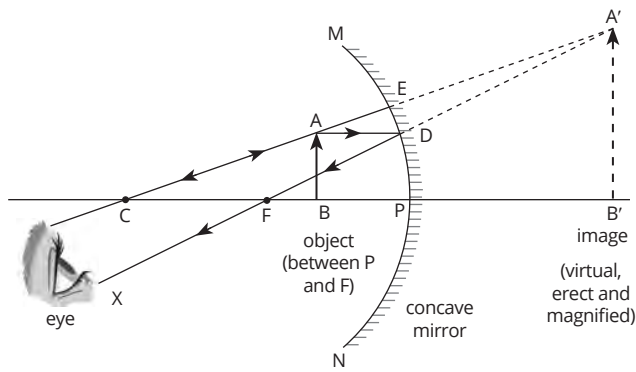

(b)

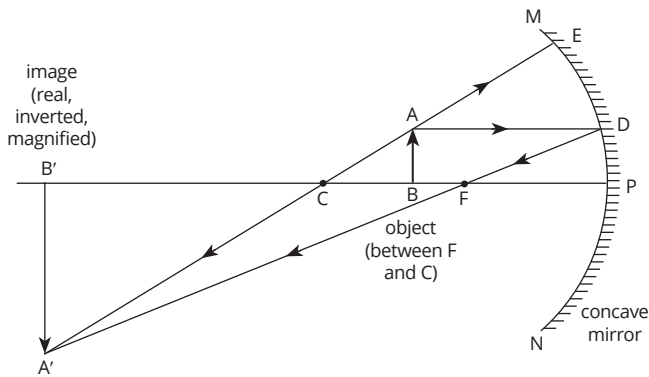

(c)

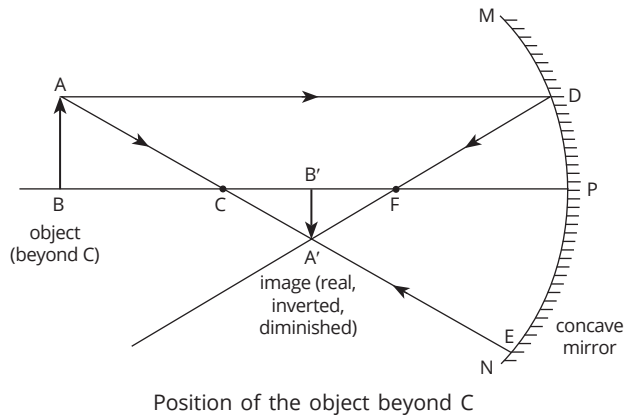
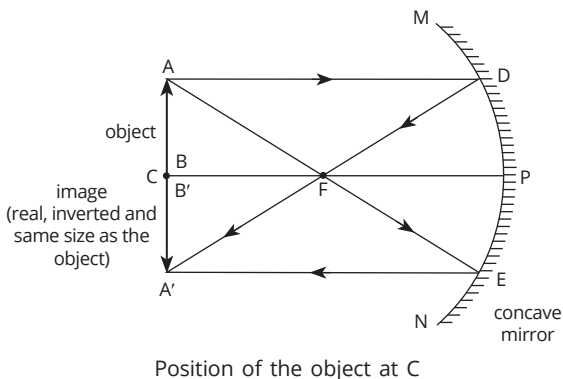

(d)

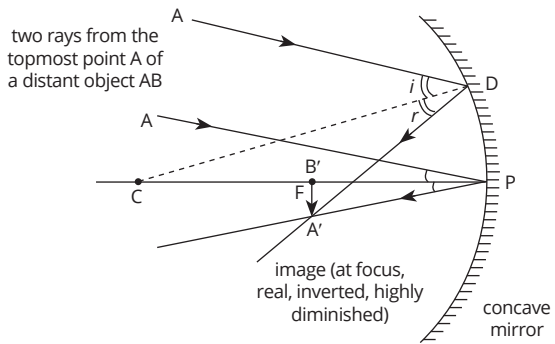

33. In the figure below, an object AB is shown placed in front of a concave mirror. Draw a ray diagram to show the formation of image for this object with suitable rays. Mention the position and nature of the image.

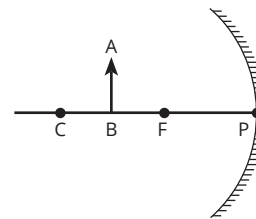

Ans. The image is formed beyond C and is real and inverted.

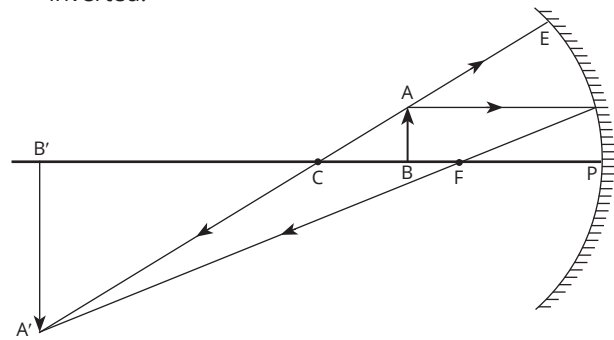

34. For an object placed at a distance of 30 cm from the pole of a mirror, an image is formed behind

the mirror at a distance of 7.5 cm from the pole of the mirror.

- What is the nature of the image?
- What is the nature of the mirror?
- Calculate the focal length of the mirror and magnification of the image.
- Draw a ray diagram to show the image formed.

Ans. (a) The image is formed behind the mirror, so it is virtual and erect in nature. Since image distance is smaller than object distance, the image is also diminished.

(b) Only a convex mirror forms a virtual, erect and diminished image, so this is a convex mirror.

(c) $u = -30$ cm, $v = 7.5$ cm

Using mirror formula,

$$\frac{1}{f} = \frac{1}{7.5} + \frac{1}{-30} = \frac{1}{10}$$

or $f = 10$ cm

$$\text{Magnification} = \frac{-v}{u} = \frac{-7.5}{-30} = \frac{1}{4} = 0.25$$

(d)

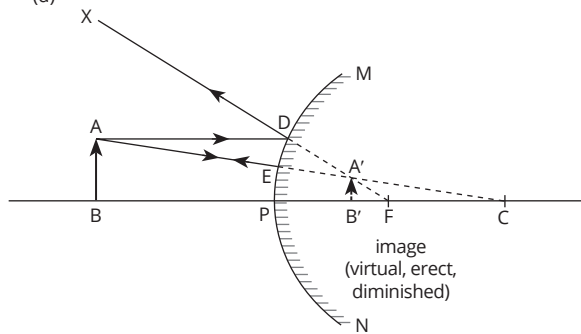

(b) The image is larger than the object.

(c) The ray diagram is given below.

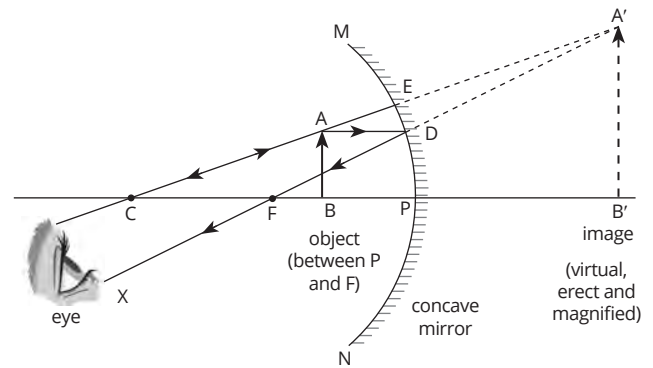

We can also obtain an erect image of the object using a convex mirror of focal length 15 cm by placing the object at any distance in front of the mirror. The image formed is smaller than the object. The ray diagram is given below.

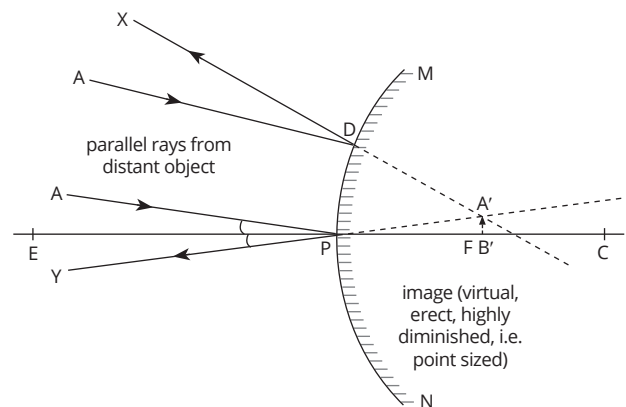

Higher Order Thinking Skills (HOTS) Questions

(Page 19)

1. We wish to obtain an erect image of an object using either a concave mirror or a convex mirror both of focal length 15 cm.

- What should be the range of distance of the object from the mirror in each case?
- Is the image larger or smaller than the object in each case?
- Draw a ray diagram to show the image formation in each case.

Ans. (a) We can obtain an erect image of an object using a concave mirror of focal length 15 cm if the object is placed in front of the mirror at a distance less than 15 cm from the pole.

2. For the given data showing object distance and focal length of three concave mirrors, answer the following questions:

Mirror	Object distance (cm)	Focal length (cm)
A	30	20
B	10	15
C	20	10

- Out of three mirrors, in which case will the mirror form an image having the same size as the object? Draw a ray diagram too.
- Which mirror is being used as a make-up mirror? Draw a ray diagram.

Ans. (a) Mirror C will form an image having the same size as the object as the object is placed at the centre of curvature of the mirror.

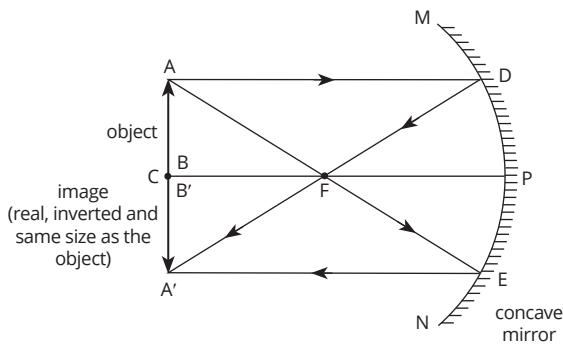

- (b) Mirror B is being used as a make-up mirror because the object distance is less than the focal length in this case. As a result, the image of the face formed is erect and enlarged.

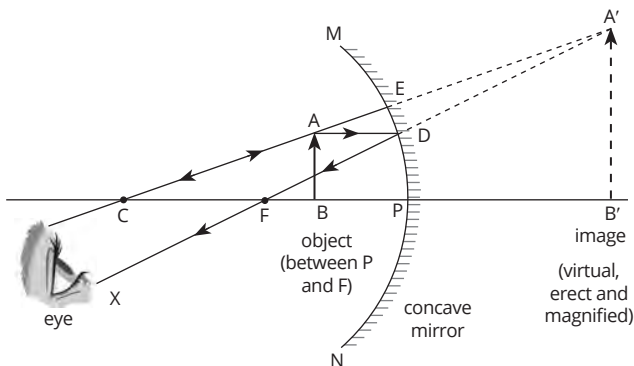

3. A person wants to see the full image of a tall building in a small mirror. Which type of mirror should be used by him?
Ans. He should use a convex mirror.
4. A concave mirror is placed in water. Will there be any change in its focal length?
Ans. No, there will be no change in the focal length.
5. If an object is brought towards a concave mirror, how do the position and size of the image change?
Ans. If an object is brought towards a concave mirror, the image grows from being diminished to the same size as the object to being enlarged. The position of the image is initially at the focus and then moves away from the mirror till it reaches infinity when the object is at the focus. When the object moves closer than the focus, the image is formed behind the mirror.
6. If a plane mirror is rotated by an angle Q , by how much will the angle between the incident and the reflected ray change?
Ans. The following figures show one case of rotation of a plane mirror, where $Q = 30^\circ$

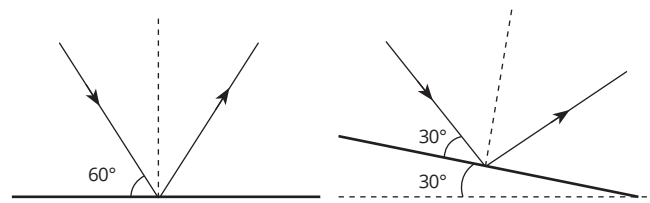

Initially, the mirror is horizontal and the light ray is incident on it at an angle of 60° . Thus, the angle between the incident ray and the reflected ray = $30^\circ + 30^\circ = 60^\circ$.

Then the mirror is rotated by 30° . Now the same ray is incident on the mirror at 30° . The angle between the incident ray and the reflected ray, now, is $60^\circ + 60^\circ = 120^\circ$.

Change in angle = $120^\circ - 60^\circ = 60^\circ = 2 \times 30^\circ$

Therefore, when the mirror rotates by Q , the angle between the incident and the reflected ray changes by $2Q$.

Self-Assessment

(Page 19)

Multiple-Choice Questions

1. A ray of light is travelling parallel to the principal axis of a concave mirror. Which of the figures given here gives the correct depiction of the reflected ray?

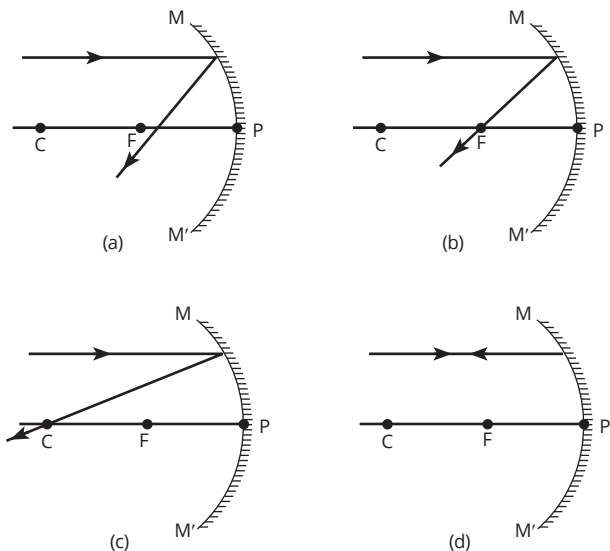

- Ans.** A ray parallel to the principal axis passes through the focus of the mirror after being reflected. Therefore, the correct answer is (b).

2. A mirror forms a virtual image of a real object.
- It must be a convex mirror.
 - It must be a concave mirror.
 - It must be a plane mirror.
 - It may be any of the mirrors mentioned above.

Ans. The correct answer is (d).

3. An object of size 2 cm is placed perpendicular to the principal axis of a concave mirror. The distance of the object from the mirror equals the radius of curvature. The size of the image will be
- 0.5 cm.
 - 1 cm.
 - 1.5 cm.
 - 2 cm.

Ans. When the object is placed at the centre of curvature, the image is also formed at the centre of curvature and is of the same size as the object. Therefore, the correct answer is (d).

4. Identify the incorrect statement regarding spherical mirrors.
- The focal length of a spherical mirror has a smaller magnitude than that of its radius of curvature.
 - The angle of incidence is equal to the angle of reflection. This is true for spherical mirrors also.
 - A spherical mirror never forms an image whose size is the same as that of the object.
 - The mirror equation is valid only if the aperture of the mirror is small.

Ans. The correct answer is (c).

Assertion–Reason Type Questions

For question numbers 5 to 14, two statements are given – one labelled Assertion (A) and the other labelled Reason (R). Select the correct answer to these questions from the codes (a), (b), (c) and (d) as given below.

- Both A and R are true and R is the correct explanation of the assertion.
- Both A and R are true but R is not the correct explanation of the assertion.
- A is true but R is false.
- A is false but R is true.

5. **Assertion:** The sun, moon and other planets are luminous objects.

Reason: Objects that emit light of their own are called luminous objects.

Ans. (a)

6. **Assertion:** Both convex and concave mirrors can form virtual images.

Reason: A virtual image is always erect with respect to the object.

Ans. (b)

7. **Assertion:** A ray of light passing through the centre of curvature of a concave mirror is reflected along the same path.

Reason: When a ray of light passes through the centre of curvature of a concave mirror, it strikes the mirror normally.

Ans. (a)

8. **Assertion:** Concave mirrors are used as shaving mirrors.

Reason: When an object is placed between the pole and focus of a concave mirror, the image is enlarged and erect.

Ans. (a)

9. **Assertion:** Concave mirrors are used in rear-view mirrors in vehicles.

Reason: Rear-view mirrors form an erect and wide view of the traffic behind the vehicle.

Ans. (d)

10. **Assertion:** The object distance (u) is always negative for plane, convex and concave mirrors according to the new Cartesian sign convention.

Reason: The image is always formed on the side opposite to the object in a plane, convex or concave mirror.

Ans. (c)

11. **Assertion:** For mirrors, the magnification (m) can also be given as $m = \frac{f}{f-u}$, where f is the focal length and u is the object distance.

Reason: The mirror formula states that $\frac{1}{f} = \frac{1}{v} - \frac{1}{u}$,

where f , u and v are the focal length, object distance and image distance, respectively.

Ans. (c)

12. **Assertion:** An image of the same size as the object can be produced in both plane and concave mirrors but never in convex mirrors.

Reason: Both plane and concave mirrors can produce virtual and erect images.

Ans. (b)

13. **Assertion:** The image formed for an object placed at infinity is highly diminished in both concave and convex mirrors.

Reason: The image formed for an object placed at infinity is virtual and erect in both concave and convex mirrors.

Ans. (c)

14. **Assertion:** If your image is initially erect but becomes inverted on moving away from a mirror, the mirror has to be convex.

Reason: The image is always of a smaller size than the object in a convex mirror.

Ans. (d)

Source-based/Case-based/Passage-based/ Integrated Questions

Answer the questions on the basis of your understanding of the following paragraphs and the related studied concepts.

15. Two-way mirrors, also known as semi-transparent mirrors, are commonly seen in films and TV shows where a person is being interrogated. The glass screen in the interrogation room works like a mirror for the people in the interrogation room. However, for people sitting in another room behind the screen, it works like transparent glass so that they can see what is happening inside the interrogation room. Such a reciprocal mirror, which is reflective on one side and transparent on the other, is prepared by coating the glass with a very thin layer of metal (usually aluminium). For the two-way mirror to work, the interrogation room has to be brightly lit, while the room behind the glass has to be dark.



- I. (a) If the mirror had been a perfectly transparent sheet of glass, how would the light rays from both rooms behave when striking the glass? What effect would this have on visibility across both rooms?
- (b) Since the two-way mirror is semi-transparent, some light rays from each room get reflected while others pass through. What happens when the reflected light rays in the bright room interact with the rays coming from the dark room? What effect does this interaction have on what the people in the bright room can see?
- (c) What happens when the reflected light rays in the dark room interact with the rays coming from the bright room? What effect does this interaction have on what the people in the dark room can see?
- (d) Two-way mirrors in interrogation rooms use plane mirrors. Can a two-way mirror work if the plane mirror is replaced by a spherical mirror, concave on one side and therefore convex on the other?
- Ans.** (a) Light rays would pass through completely. This would allow people from both rooms to see each other.
- (b) The reflected rays in the bright room are stronger than the rays from the dark room; thus, people

in the bright room only see their image in the glass.

- (c) The reflected rays in the dark room are weaker than the rays from the bright room; thus, people in the dark room can see through the glass.
- (d) Yes.
- II. (a) The characteristic that will remain unaltered as light moves from one medium to another is
- velocity.
 - wavelength.
 - frequency.
 - none of the above.

Ans. (iii) frequency.

- (b) Which of the following is a converging mirror?
- Plane mirror
 - Concave mirror
 - Convex mirror
 - None of these

Ans. (ii) Concave mirror

- (c) Two-way mirrors in interrogation rooms use plane mirrors. What is/are the characteristic/s of an image formed by a plane mirror?

- The image is laterally inverted.
- The image is virtual.
- The image is erect.
- All of the above.

Ans. (iv) All of the above.

- (d) Can a two-way mirror work if the plane mirror is replaced by a spherical mirror, concave on one side and therefore; convex on the other?

- No
- Yes
- Sometimes
- Cannot say

Ans. (ii) Yes

- (e) The image of an object formed by a plane mirror is

- diminished.
- real.
- virtual.
- none of these.

Ans. (iii) virtual.

16. Funhouse mirrors are common attractions at fairs and amusement parks. Spherical mirrors of different kinds are used to present odd-shaped images of people standing in front of them. The trick in designing these attractions is to use spherical mirrors with a low curvature, such that they resemble plane mirrors at first glance. When a person stands in front of a mirror like this, he or she expects a regular image as seen in a plane mirror. However, the angle of light has been distorted by the spherical mirror, and the image seen is fatter, longer, wider, or distorted, depending upon the mirror used.



- I. (a) What type of spherical mirror will make a person look fat and short in the image? What type of spherical mirror will make her look thin and tall?
- (b) In which of the two types of spherical mirrors will a person's image be erect when close to the mirror but become inverted when the person moves away from the mirror?
- (c) If both types of mirrors were in an open area, which type of mirror would capture a greater area of the image kept in front of it?
- (d) A 1.6-m tall woman stands 2 m in front of a funhouse convex mirror with a focal length of 0.5 m. What is the height of her image seen in the mirror?

- Ans.** (a) Concave for thin and tall, convex for short and fat
- (b) Concave mirror
- (c) Convex mirror
- (d) 0.32 m

- II. (a) A diminished virtual image can be formed only in which of the following mirrors?
- (i) A plane mirror
- (ii) A concave mirror
- (iii) A convex mirror
- (iv) None of the above

Ans. (iii) A convex mirror

- (b) The focal length of a convex mirror is 20 cm. What will be its radius of curvature?
- (i) 20 cm (ii) 30 cm
- (iii) 40 cm (iv) 60 cm

Ans. (iii) 40 cm

- (c) Anuj stands straight in front of a mirror in the fun house at a distance of 30 cm away from it. He sees his erect image whose height is $1/5$ th of his real height. The mirror used is a
- (i) plane mirror.
- (ii) convex mirror.
- (iii) concave mirror.
- (iv) none of the above.

Ans. (ii) convex mirror.

- (d) The focal length of a spherical mirror is
- (i) maximum for red light.

- (ii) maximum for white light.
- (iii) maximum for green light.
- (iv) same for all lights.

Ans. (iv) same for all lights.

- (e) Which one of the following does not apply to a concave mirror?
- (i) Focal length is negative.
- (ii) Image distance is always positive.
- (iii) Height of image can be negative or positive.
- (iv) None of the above.

Ans. (ii) Image distance is always positive.

Very Short Answer Type Questions

17. What are the values of angle of incidence and the angle of reflection for normal incidence on a plane mirror?
- Ans.** When a light ray is incident on a mirror along the normal, the angle of incidence is 0. Therefore, the angle of reflection is also 0.
18. In the diagram, the ray is incident parallel to the principal axis. Redraw the diagram, showing the reflected ray.

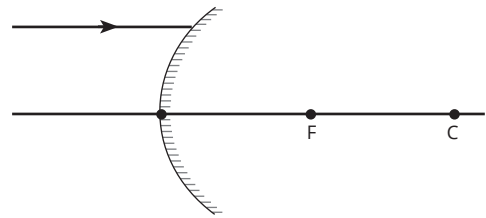

- Ans.** The ray gets reflected such that it appears to be coming from the focus of the mirror. The diagram is shown below:

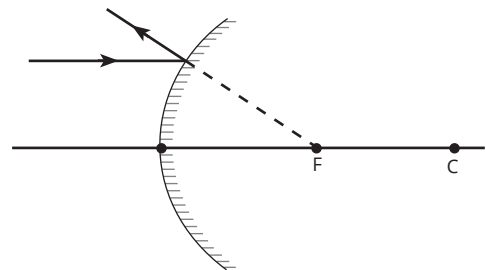

19. What is the minimum distance between an object and its real image in case of a concave mirror?

Ans. The minimum distance possible between the object and its real image in case of a concave mirror is 0. This happens when the object is at the centre of curvature and the image is also formed at the centre of curvature.

20. Why does a light ray passing through the centre of curvature of a spherical mirror return along the same path after reflection from the mirror?

Ans. This happens because the light ray is incident on the mirror along the normal. The angle of incidence is 0; therefore, the angle of reflection is also 0.

21. How can we obtain an erect and enlarged image of an object using a mirror?

Ans. An erect and enlarged image is possible when we use a concave mirror and place the object between the focus and the pole of the mirror. The image thus formed is virtual in nature.

Short Answer Type-I Questions

22. A man standing in front of a mirror finds his image having a very small head, a fat body and legs of normal size. What are the shapes of the three parts of the mirror?

Ans. The given mirror consists of three different types of mirrors. The upper part, responsible for the small head in the image is a convex mirror. The middle part, responsible for the fat body in the image is a concave mirror. The lowest part, responsible for normal-sized legs in the image is a plane mirror.

23. Find the position of an object which when placed in front of a concave mirror of focal length 20 cm, produces a virtual image which is twice the size of the object.

Ans. $f = -20$ cm, $m = 2$

$$m = \frac{-v}{u}$$

or $2 = \frac{-v}{u}$

or $v = -2u$

Using mirror formula,

$$\frac{1}{-20} = \frac{1}{-2u} + \frac{1}{u} = \frac{1}{2u}$$

or $u = -10$ cm

24. State the type of mirrors required to get (a) virtual and diminished image of an object, and (b) virtual and enlarged image of an object. Draw image formation in both the cases in the form of ray diagrams.

Ans. (a) Convex mirror.

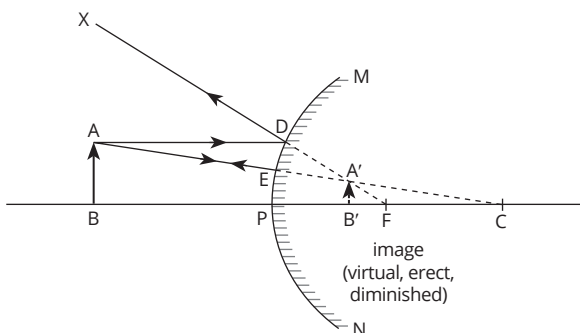

(b) Concave mirror.

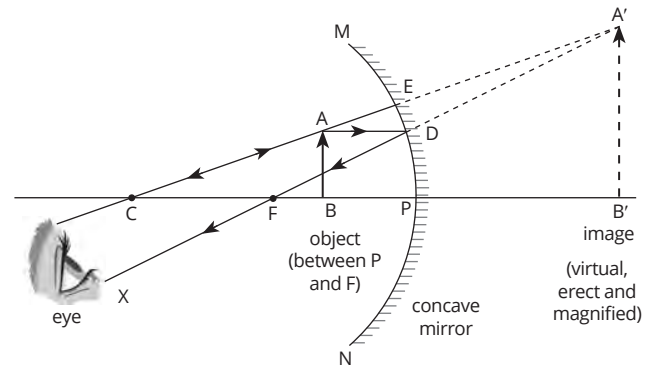

25. The radius of curvature of a concave mirror is 50 cm. Where should an object be placed from the mirror so as to form its image at infinity? Justify your answer.

Ans. For image to be formed at infinity in a concave mirror, the object has to be placed at the focus. Since the radius of curvature is 50 cm, the focal length of the given concave mirror is 25 cm. Therefore, the object should be placed 25 cm in front of the mirror.

Short Answer Type-I Questions

26. Draw the image formation by a concave mirror of focal length 15 cm for the following positions of the object. Diagrams may not be drawn to the scale. Indicate the nature and relative size of image in each case:

- (a) Object is placed at 30 cm from the mirror.
- (b) Object is placed 10 cm from the mirror.

Ans. (a) 30 cm is the radius of curvature of the mirror. Therefore, the image formed is real, inverted, and of the same size as the object.

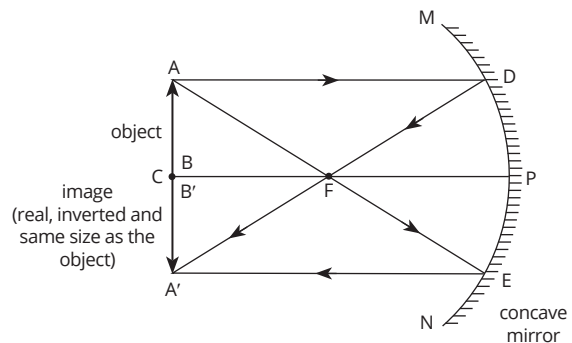

(b) When the object is placed between the focus and the pole of a concave mirror, the image formed is virtual, erect, and enlarged.

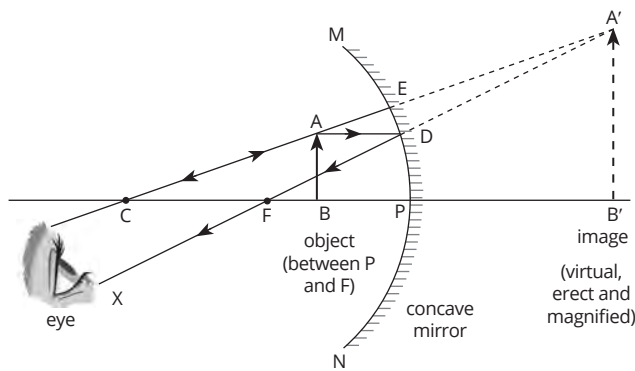

27. A convex mirror used as a rear-view mirror in a bus has a focal length of 200 cm. If a scooter is located at 400 cm from this mirror, find the position, nature and size of the image formed by the mirror.

Ans. $f = 200$ cm, $u = -400$ cm

Using mirror formula,

$$\frac{1}{200} = \frac{1}{v} + \frac{1}{-400}$$

or $v = 133.33$ cm

Therefore, the image is virtual, erect, and diminished to 1/3rd the size of the object.

28. An object 5 cm tall was placed in front of a spherical mirror at 20 cm distance from the mirror. If a virtual image, 10 cm tall, was formed behind the mirror, find the focal length of the mirror and the position of the image. Name the type of mirror used.

Ans. Since a virtual and enlarged image is formed, the mirror is a concave mirror.

$u = -20$ cm, $h = 5$ cm, $h' = 10$ cm

$$\frac{h'}{h} = \frac{-v}{u}$$

or $\frac{10}{5} = \frac{-v}{-20}$

or $v = 40$ cm

Using mirror formula,

$$\frac{1}{f} = \frac{1}{40} + \frac{1}{-20} = \frac{-1}{40}$$

or $f = -40$ cm

29. A shaving mirror has a radius of curvature of 30 cm. A man sees his image 2.5 times the size of his face. How far is the mirror from his face?

Ans. Radius of curvature = -30 cm (this is a concave mirror); therefore, focal length = -15 cm

$m = 2.5$ (sign is positive as the image is virtual and erect)

$$\frac{-v}{u} = 2.5$$

or $v = -2.5u$

Using mirror formula, $\frac{1}{-15} = \frac{1}{-2.5u} + \frac{1}{u}$

or $u = -9$ cm

Therefore, the mirror is 9 cm from the man's face.

Long Answer Type Questions

30. An object is held at 30 cm in front of a convex mirror of focal length 15 cm. At what distance from the convex mirror should a plane mirror be held so that the images in the two mirrors coincide with each other?

Ans. For the convex mirror,

$f = 15$ cm, $u = -30$ cm

Using mirror formula,

$$\frac{1}{15} = \frac{1}{v} + \frac{1}{-30}$$

or $v = 10$ cm

So, the image is formed 10 cm behind the mirror. The distance between the image and the object is $30 + 10 = 40$ cm. For an image from a plane mirror to coincide with this image, the plane mirror will have to be placed exactly between the object and the image. Therefore, the distance between the object and the plane mirror is $\frac{40}{2} =$

20 cm. Now, the object is 20 cm in front of the plane mirror and 30 cm in front of the convex mirror. Therefore, the distance between the plane mirror and the convex mirror is 10 cm. Both the mirrors have their reflecting surface facing the object.

31. When an object is placed at a distance of 60 cm from a convex mirror, the magnification produced is $\frac{1}{2}$. Where should the object be placed to get a

magnification of $\frac{1}{3}$?

Ans. $m_1 = \frac{1}{2}$, $u_1 = -60$ cm

$$m_1 = \frac{-v_1}{u_1}$$

or $v_1 = -m_1 \times u_1$

$$= \frac{-1}{2} \times -60 = 30$$
 cm

$$\frac{1}{f} = \frac{1}{30} + \frac{1}{-60}$$

or $f = 60$ cm

$$m_2 = \frac{1}{3}$$

or $\frac{-v_2}{u_2} = \frac{1}{3}$

or $v_2 = \frac{-u_2}{3}$

$$\begin{aligned} \frac{1}{f} &= \frac{1}{v_2} + \frac{1}{u_2} \\ &= \frac{-3}{u_2} + \frac{1}{u_2} \\ &= \frac{-2}{u_2} \end{aligned}$$

or $u_2 = -2f$
 $= -120 \text{ cm}$

32. List the sign conventions for reflection of light by spherical mirrors. Draw a diagram and apply these conventions in the determination of focal length of a spherical mirror which forms a $\frac{1}{3}$ times

magnified virtual image of an object placed 18 cm in front of it.

Ans. Sign convention at a glance

Parameter	For concave mirror	For convex mirror
1. Distance of the object	u is negative	u is negative
2. Distance of the virtual image	v is positive	v is positive
3. Distance of the real image	v is negative	No real image
4. Focal length	f is negative	f is positive
5. Radius of curvature	R is negative	R is positive
6. Height of the erect and virtual image	h' is positive	h' is positive
7. Height of the inverted and real image	h' is negative	No real image
8. Height of the object	h is positive	h is positive

Since the image is virtual and diminished, the mirror is a convex mirror.

$$u = -18 \text{ cm}$$

$$m = \frac{1}{3}$$

or $\frac{-v}{u} = \frac{1}{3}$

or $v = \frac{-1}{3} \times -18 = 6 \text{ cm}$

$$\frac{1}{f} = \frac{1}{6} + \frac{1}{-18} = \frac{1}{9}$$

or $f = 9 \text{ cm}$

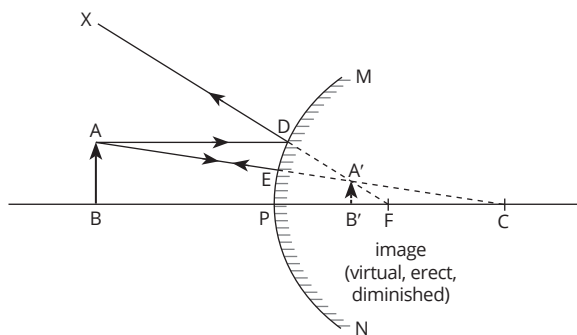

Let's Complete

(Page 23)

1. If an incident ray passes through the centre of curvature of a spherical mirror, the reflected ray will
- pass through the pole.
 - pass through the focus.
 - retrace its path.
 - be parallel to the principal axis.

Ans. The correct answer is (c).

2. To get an image larger than the object, one can use
- a convex mirror but not a concave mirror.
 - a concave mirror but not a convex mirror.
 - either a convex mirror or a concave mirror.
 - a plane mirror.

Ans. The correct answer is (b).

3. What is the magnification produced by a rear-view mirror fitted in a vehicle?
- Equals to 1
 - More than 1
 - Less than 1
 - Can be either more or less than 1, depending on the position of the object in front of it.

Ans. The image in a rear-view mirror is smaller than the size of the object. Therefore, the correct answer is (c).

4. The bulb used in a torch light is placed at a distance x from the mirror used. The value of x is

- $\frac{f}{2}$.
- f .
- $\frac{f}{3}$.
- $3f$.

Ans. The correct answer is (b).

5. Focal length of a concave mirror depends on its
- size.
 - aperture.
 - radius of curvature.
 - material used.

Ans. The correct answer is (c).

6. Which one of the following usually forms a real image?

- (a) Plane mirror (b) Concave mirror
(c) Convex mirror (d) All of these

Ans. The correct answer is (b).

7. The focal length of a concave mirror that produces four times large image of an object held at 5 cm from the mirror is

- (a) - 20 cm. (b) - 4 cm.
(c) 20 cm. (d) 5 cm.

Ans. $u = -5$ cm; $m = -4$ (as image is real and inverted)

$$m = \frac{-v}{u}$$

or $v = (-m \times u)$
 $= -(-4) \times -5$ cm = -20 cm

$$\frac{1}{f} = \frac{1}{-20} + \frac{1}{-5} = \frac{-1}{4}$$

or $f = -4$ cm

Therefore, the correct answer is (b).

8. A child runs towards a plane mirror with a velocity of 2 m/s. The speed with which her image moves towards her is

- (a) 2 m/s. (b) zero.
(c) 4 m/s. (d) none of these.

Ans. The image is as far behind the mirror as the object is in front of the mirror. Therefore, the image will move towards her with a speed equal to 2×2 m/s = 4 m/s. The correct answer is (c).

9. A ray of light falls on a plane mirror making an angle of 30° with the mirror. On reflection, the ray deviates through an angle of

- (a) 30° . (b) 60° .
(c) 120° . (d) 180° .

Ans. The angle by which the ray deviates is the $180^\circ -$ (sum of angle of incidence and angle of reflection). The angle of reflection = angle of incidence = $90^\circ - 30^\circ = 60^\circ$. The sum = $60^\circ + 60^\circ = 120^\circ$. Therefore, the angle of deviation = $180^\circ - 120^\circ = 60^\circ$

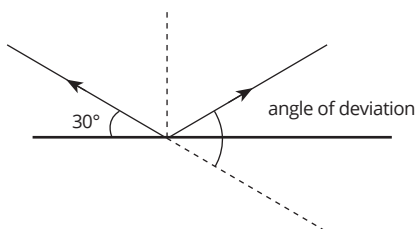

Therefore, the correct answer is (b).

10. The linear magnification produced by a convex mirror is always positive because

- (a) convex mirror is a small mirror.
(b) image formed by a convex mirror is always smaller in size than the object.
(c) image formed by a convex mirror is real.
(d) image formed by a convex mirror is always virtual and erect.

Ans. According to the sign convention, magnification is positive if the image is virtual and erect. Therefore, the correct answer is (d).

Value-based Questions

(Optional) (Page 23)

1. Raman's younger sister got confused when she tried to read a text page from a mirror. Raman intervened and explained that it is due to the phenomenon in which left of the object becomes the right of the image and vice versa.

- (a) What is the name given to the above characteristic of the image formed by the plane mirror in the above case?
(b) What values does Raman's action depict?

Ans. (a) Lateral inversion

(b) Patience, willingness to teach youngsters

2. One day, Susan was going to school in her uncle's car. She found that the rear-view mirror was missing in the car. She requested her uncle to get one installed so that he would be safer while driving?

- (a) What type of mirror is used in a car's rear-view mirror? Give reason.
(b) What values are shown by Susan?

Ans. (a) Convex mirror. The image formed in a convex mirror is highly diminished due to which it gives a wide field of view of the traffic at the back of the vehicle; the image produced is also erect.

(b) Concern for a family member, understanding of safety features, confidence

3. Asif was fetching a plane mirror, a convex mirror and a concave mirror from his laboratory to his class when he mixed them up by mistake. He wanted to put them in separate packets and label them. He sought Ravneet's help who managed to distinguish the mirrors without even touching them.

- (a) How was Ravneet able to distinguish between the three mirrors without touching them?
(b) What, according to you, are the values displayed by Ravneet?

Ans. (a) He conducted the following experiment. He asked to bring each mirror one by one close to his face and observe the image formed in it. The mirror is a

- (i) plane mirror, if the image is erect, of the same size as the object and does not change size or nature on moving the mirror closer to or away from the face
 - (ii) concave mirror, if the image is erect, magnified and becomes inverted on moving the mirror away from the face
 - (iii) convex mirror, if the image is erect, diminished and remains erect on moving the mirror away from the face
- (b) Willingness to help friends, practical application of concepts learned in classroom

(II) REFRACTION OF LIGHT

Milestone 1

(Page 30)

Multiple-Choice Questions

1. The ratio of $\sin i$ and $\sin r$ is
- (a) a variable.
 - (b) a constant.
 - (c) zero.
 - (d) none of these.

Ans. The ratio of $\sin i$ and $\sin r$ is the refractive index, which is a constant. Therefore, the correct answer is (b).

2. If a ray of light enters water from air such that its angle with the surface of water is 60° , the angle of incidence is

- (a) 30° .
- (b) 60° .
- (c) 90° .
- (d) 120° .

Ans. If the ray of light makes an angle of 60° , the angle it makes with the normal is $90^\circ - 60^\circ = 30^\circ$. This is the angle of incidence. Therefore, the correct answer is (a).

3. In the above question, if the refractive index of water is 1.33, the angle of refraction is

- (a) 12° .
- (b) 22° .
- (c) 32° .
- (d) 42° .

Ans. We know that

$$n_{21} = \frac{\sin i}{\sin r}$$

or $1.33 = \frac{\sin 30^\circ}{\sin r}$

or $\sin r = \frac{\left(\frac{1}{2}\right)}{1.33} = 0.375$

or $r = 22^\circ$

Therefore, the correct answer is (b).

4. Amongst air, water, glass and diamond, the highest refractive index is of

- (a) air.
- (b) glass.
- (c) diamond.
- (d) water.

Ans. The correct answer is (c).

Very Short Answer Type Questions

5. Between kerosene and water, which substance has higher optical density and which has higher mass density?

Ans. Kerosene has higher optical density, while water has higher mass density.

6. You are given three different media: A ($n = 1.5$), B ($n = 1.7$) and C ($n = 1.31$). In which of these does light travel the fastest?

Ans. Since absolute refractive index of a medium = $\frac{\text{speed of light in air}}{\text{speed of light in that medium}}$, for a constant

value of speed of light in air, we have

Absolute refractive index of a medium

$$\propto \frac{1}{\text{speed of light in that medium}}$$

The lower the refractive index, the higher is the speed of light in the medium.

Since C has the lowest refractive index among the three media, light travels the fastest in C.

7. Why does refractive index have no unit?

Ans. Refractive index has no unit because it is a ratio of quantities having the same units.

8. Why is there no effect of refraction on looking at objects through a glass pane?

Ans. A glass pane is thin, so the shifts in the rays of light passing through it are not noticeable.

Short Answer Type-I Questions

9. How do the lemons kept in water in a glass tumbler and *rasgullas* kept in sugar syrup in a glass jar appear when viewed from the side? Give reasons.

Ans. Lemons kept in water in a glass tumbler and *rasgullas* kept in sugar syrup in a glass jar appear to be larger than their actual size. This is because light rays traveling from the liquid into the air bend away from the normal due to refraction and appear to us as if they are originating from a point above the actual position of the lemons or the *rasgullas*.

10. How will the appearance of displacement of a pencil differ if instead of water it is immersed in liquids like kerosene or turpentine oil?

Ans. Kerosene or turpentine oil is optically denser

compared to water. Therefore, light rays coming from these oils into air will undergo greater amount of refraction. As a result, a pencil immersed in kerosene or turpentine oil will appear to be bent even more than it will when it is immersed in water.

11. A beam of light passes from air into a substance M. If the angle of incidence is 40° and the angle of refraction is 30° , calculate the refractive index of the substance. Given, $\sin 40^\circ = 0.6428$, $\sin 30^\circ = 0.5$.

Ans. Refractive index of the substance

$$\begin{aligned} &= \frac{\sin i}{\sin r} = \frac{\sin 40^\circ}{\sin 30^\circ} \\ &= \frac{0.6428}{0.5} = 1.2856 \end{aligned}$$

Short Answer Type-II Questions

12. What is observed when a thick glass slab is placed over some printed matter? Why does this happen? How will this effect change if the glass slab is replaced with a transparent plastic slab?

Ans. When a thick glass slab is placed over printed matter, the letters appear raised. This is because of refraction of light that occurs when it first passes from air into the glass and then from glass into the air. Any other transparent material will have a different refractive index and so the level by which the letters appear raised will be different. In the case of a transparent plastic slab, the refractive index is lower than glass, so the letters will appear less raised or almost not at all.

13. Light enters from air into dense flint glass having refractive index 1.65. What is the speed of light in the dense flint glass? If the refractive index of turpentine oil is 1.47, what is the refractive index of the dense flint glass with respect to turpentine oil? The speed of light in vacuum is 3×10^8 m/s.

Ans. Refractive index of flint glass

$$= \frac{\text{speed of light in air}}{\text{speed of light in flint glass}}$$

or Speed of light in flint glass

$$\begin{aligned} &= \frac{\text{speed of light in air}}{\text{refractive index of flint glass}} \\ &= \frac{3 \times 10^8 \text{ m/s}}{1.65} = 1.82 \times 10^8 \text{ m/s} \end{aligned}$$

Speed of light in turpentine oil

$$\begin{aligned} &= \frac{\text{speed of light in air}}{\text{refractive index of turpentine oil}} \\ &= \frac{3 \times 10^8 \text{ m/s}}{1.47} \\ &= 2.04 \times 10^8 \text{ m/s} \end{aligned}$$

Refractive index of flint glass with respect to turpentine oil

$$\begin{aligned} &= \frac{\text{speed of light in turpentine oil}}{\text{speed of light in flint glass}} \\ &= \frac{2.04 \times 10^8 \text{ m/s}}{1.82 \times 10^8 \text{ m/s}} = 1.12 \end{aligned}$$

14. What is the principle of reversibility of light? Show that the incident ray is parallel to the emergent ray of light when light falls obliquely on a side of a rectangular glass slab.

Ans. If a reflected or a refracted ray of light is reversed in direction, it will retrace its original path. This is known as the principle of reversibility of light.

Apparatus required: Rectangular glass slab, white sheet of drawing paper, drawing board, drawing pins and all-purpose pins.

Method

- Fix the sheet of white drawing paper on the drawing board with the help of drawing pins.
- Place the rectangular glass slab at the centre of the paper, mark its boundary with a sharp pencil and then remove the glass slab. Join the marked boundary and label it as LMNO.
- Mark a point B on the side LM and draw the normal NBN'. Make a suitable angle (say 30°) with the normal and fix two pins P_1 and P_2 in vertical position, such that the minimum distance between the pins is 5 cm. Replace the glass slab in the marked boundary LMNO.
- Looking through the glass slab from opposite side NO, locate the images of the pins P_1 and P_2 which appear as L_1 and L_2 due to refraction. Fix two more pins P_3 and P_4 such that these pins and the images L_1 and L_2 of the pins P_1 and P_2 are in straight line.
- Remove the pins P_1 , P_2 , P_3 and P_4 one by one and mark small circles around the positions of these pins with a pencil. Now, remove the glass slab.
- Join the points P_1 and P_2 and make a line AB. The line AB represents the incident ray. Join P_3 and P_4 to meet side NO at C and make a line CD. The line CD represents the emergent ray. Also, join B and C. The line BC represents the refracted ray.
- Measure the angle of incidence $\angle ABN$ ($\angle i$) and the angle of refraction $\angle N'BC$ ($\angle r$).
- Repeat the experiment for different angles of incidence and determine the corresponding angles of refraction.

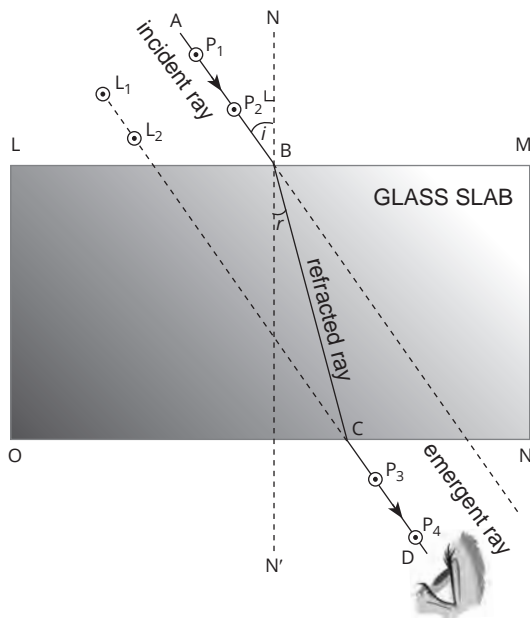

In the above experiment, it can be seen that the emergent ray CD and the incident ray AB are parallel to each other since the angle of emergence is equal to the angle of incidence for all values of angle of incidence.

Long Answer Type Question

15. Draw a ray diagram indicating the change in the path of light when a ray of light travelling
- in air is incident on water.
 - in air is incident on a glass slab.
 - in water emerges into air.
 - in glass emerges into air.

Ans. (a)

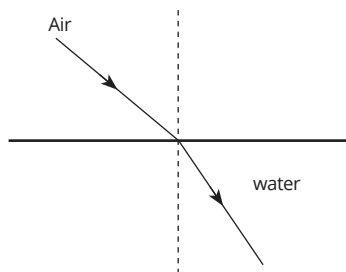

(b)

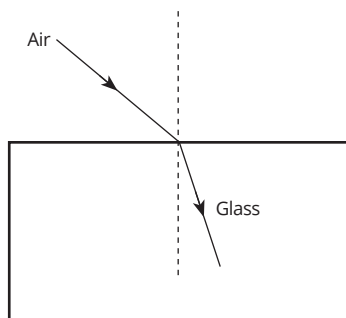

(c)

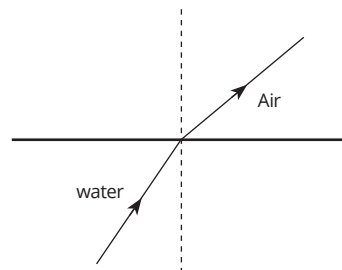

(d)

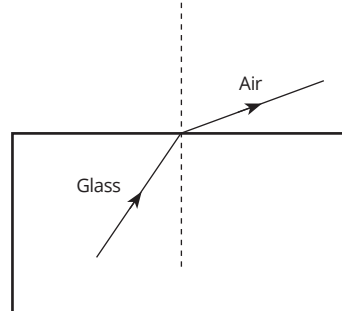

Milestone 2

(Page 39)

Multiple-Choice Questions

1. The image formed by a convex lens when the object is placed between the optical centre and the principal focus is
- diminished.
 - of the same size.
 - magnified.
 - none of these

Ans. The correct answer is (c).

2. In a lens, all distances are measured from
- focus.
 - optical centre.
 - pole.
 - radius of curvature.

Ans. The correct answer is (b).

3. A thin lens and a spherical mirror have a focal length of + 15 cm each.
- Both are convex.
 - The lens is convex and the mirror is concave.
 - The lens is concave and the mirror is convex.
 - Both are concave.

Ans. According to the sign conventions for lenses and mirrors, we can see that focal length is positive for convex lenses and convex mirrors. Therefore, the correct answer is (a).

4. A convex lens forms a virtual image when an object is placed at a distance of 18 cm from it. The focal length of the lens must be
- greater than 36 cm.
 - greater than 18 cm.
 - less than 36 cm.
 - less than 18 cm.

Ans. We know that a convex lens forms a virtual image only when the object is placed between the optical centre and the focus. Here, the object is placed at 18 cm, so we can say with certainty that the distance between the optical centre and the focus of this lens is greater than 18 cm. Therefore, the correct answer is (b).

5. The lens used mainly in spectacles for the correction of short-sightedness is
- (a) plane lens. (b) concave lens.
(c) convex lens. (d) none of these.

Ans. The correct answer is (b).

6. Which one of the following materials cannot be used for making a lens?
- (a) Plastic (b) Water
(c) Flint glass (d) Clay

Ans. The material used to make a lens has to allow light to pass through it. Therefore, the correct answer is (d).

Very Short Answer Type Questions

7. Name the instrument used for measuring the power of a lens.
- Ans.** The instrument used to measure the power of a lens is called a dioptremeter.
8. Suggest one point of a lens through which a ray of light passes undeviated.
- Ans.** A light ray can pass through the optical centre of a lens without deviation.
9. What is the sign for the values of f and u for a concave lens by convention?
- Ans.** The sign is negative for both f and u for a concave lens by convention.
10. Where should a pin be placed before a convex lens so that its image is formed at infinity?
- Ans.** The pin should be placed at the principal focus of the lens.

Short Answer Type-I Questions

11. How can you find the approximate focal length of a convex lens?
- Ans.** We can find the approximate focal length of a convex lens by focusing the light from sun on a sheet of paper. We take a convex lens and face it towards the sun. We take a sheet of paper and place it close to the lens such that the lens is between the sun and the sheet. When we move the lens slowly away from the sheet, at one stage, a very small, bright image will be formed on the sheet. The distance between the lens and the sheet in this position is the focal length of the convex lens.

12. Where should an object be placed in front of a convex lens so as to obtain its
- (a) real, inverted and magnified image.
(b) virtual, erect and magnified image.
(c) real, inverted and highly diminished image.
(d) real, inverted and same-sized image.

Ans. If the principal focus of the lens is F , then the positions for the object are as follows:

- (a) At F or between F and $2F$
(b) Between F and optical centre
(c) At infinity
(d) At $2F$

13. A beam of light travelling parallel to the principal axis of a concave lens appears to diverge from a point 20 cm behind the lens after passing through the lens. Find the power of the lens.

Ans. Based on the given information, we know that the focal length of the concave lens is -20 cm or -0.2 m

$$\begin{aligned} \text{Power of the lens} &= \frac{1}{-0.2 \text{ m}} \\ &= -5 \text{ D} \end{aligned}$$

14. An object is placed at a distance of 50 cm from a concave lens of focal length 20 cm. Find the nature and position of the image.

Ans. Given, $u = -50$ cm, $f = -20$ cm

Using lens formula,

$$\frac{1}{-20} = \frac{1}{v} - \frac{1}{-50}$$

$$\text{or } \frac{1}{v} = \frac{-1}{20} - \frac{1}{50} = \frac{-7}{100}$$

$$\text{or } v = -14.29 \text{ cm}$$

A concave lens always forms a virtual image. Moreover, since the sign of the image is negative (same as the object), it is an erect image.

Short Answer Type-II Questions

15. Explain with the help of ray diagrams why a convex lens is called a converging lens and a concave lens is called a diverging lens.

Ans.

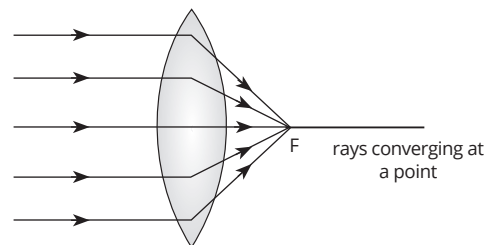

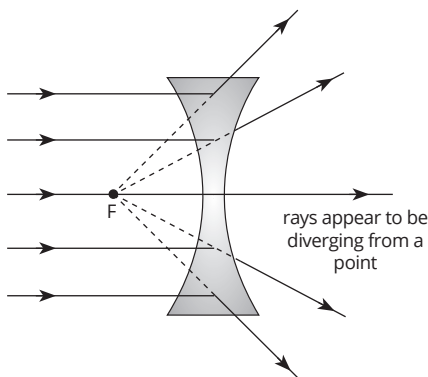

As we can see from the given images, parallel rays of light are made to meet at a point when they pass through a convex lens while they appear to be diverging from a single point when they pass through a concave lens. This is why, a convex lens is called a converging lens and a concave lens is called a diverging lens.

16. A 2 cm long pin is placed at a distance of 16 cm from a convex lens. Assuming it to be perpendicular to the principal axis, find the position, size and the nature of the image if the focal length of the lens is 12 cm.

Ans. Given, $u = -16$ cm, $f = 12$ cm, $h = 2$ cm

Using lens formula,

$$\frac{1}{f} = \frac{1}{v} - \frac{1}{u}$$

or
$$\frac{1}{12} = \frac{1}{v} - \frac{1}{-16}$$

or
$$v = +48$$
 cm

(the sign is different from that of the object, so the image is inverted)

We also know that $\frac{h'}{h} = \frac{v}{u}$, where h' is the size of the image

or
$$h' = \frac{h \times v}{u} = \frac{2 \text{ cm} \times 48 \text{ cm}}{-16 \text{ cm}} = -6 \text{ cm}$$

Therefore, the image is an enlarged, inverted, and real image of size 6 cm formed at 48 cm from the optical centre on the other side of the lens.

17. An object is placed before a concave lens of focal length 12 cm. The size of the image formed by the lens is half the size of the object. Calculate the distance of the object from the lens.

Ans. Given, $f = -12$ cm, $m = \frac{1}{2}$

$$m = \frac{v}{u}$$

or
$$\frac{v}{u} = \frac{1}{2}$$

or
$$v = \frac{u}{2}$$

Using lens formula, we have

$$\frac{1}{f} = \frac{1}{v} - \frac{1}{u}$$

or
$$\frac{1}{-12} = \frac{2}{u} - \frac{1}{u} = \frac{1}{u}$$

or
$$u = -12$$
 cm

Long Answer Type Questions

18. Two thin lenses of power + 2 D and - 1.5 D are placed in contact. Find the (a) power and (b) focal length of the combination of the lenses.
(c) Also state the nature of the lens formed by the combination of these two lenses.

Ans. Given $P_1 = +2$ D, $P_2 = -1.5$ D

(a) Power of the combination of the lenses

$$= P_1 + P_2 = +2 \text{ D} + (-1.5 \text{ D}) = +0.5 \text{ D}$$

(b) $P = \frac{1}{f}$ or $f = \frac{1}{P} = \frac{1}{0.5 \text{ D}} = 2 \text{ m} = 200 \text{ cm}$

(c) Since the focal length has a positive sign, the lens formed by the combination of the two lenses behaves as a convex lens.

19. To construct a ray diagram, we use two light rays for which it is easy to know their directions after refraction from the lens. List these two rays and state the path of these rays after refraction. Use these two rays to locate the image of the object placed between f and $2f$ of a convex lens.

Ans. The two rays used are: (i) a ray travelling parallel to the principal axis, which converges at the focus after passing through the lens, and (ii) a ray passing through the optical centre of the lens, which passes through the lens without deviation. The image formation using these two rays is shown in the figure below.

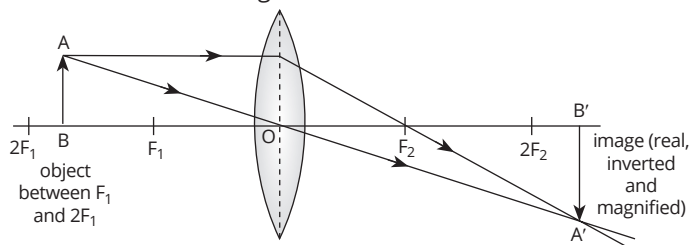

Higher Order Thinking Skills (HOTS) Questions

(Page 41)

1. How will the following be affected on cutting a converging lens into two halves along the principal axis?
- Focal length
 - Intensity of the image formed by half lens

Ans. (a) The focal length depends on the overall curvature of the lens, which does not change when it is halved. Therefore, the focal length remains the same.

(b) The intensity of the image depends upon the amount of light passing through the lens. When the lens is halved, the amount of light passing through one part is half that of the complete lens. Therefore, the intensity becomes half of what it was originally.

2. If you have one convex lens of focal length 25 cm and another of focal length 50 cm, which one will you use to obtain more convergent light? Justify your answer with a ray diagram, with a scale to represent 10 cm by 1 cm.

Ans. We know that the power of a lens is the reciprocal of its focal length. This power is the diverging or converging power of a lens. Therefore, the lower the focal length of a lens, the higher is its converging or diverging power. Thus, we will use the convex lens of focal length 25 cm out of the two to obtain more converging light. The ray diagrams are given below.

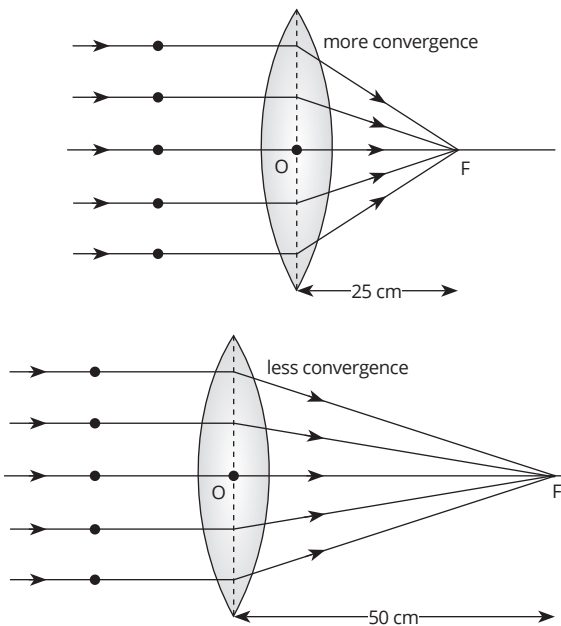

3. When a bird in air looks downwards at a fish in water, does the fish appear raised or deeper than it actually is? When the fish looks upwards at the bird, does the bird appear nearer or farther away?

Ans. The following two images explain the situation clearly. In the first figure, the bird looks down at the fish. In this case, light travels from a denser medium (water) to a rarer medium (air). As a result, the light ray moves away from the normal as shown. To the bird, it will appear as if the light

ray is originating from a position higher than it actually is. Thus, the fish will appear raised to the bird.

In the second figure, the fish looks up at the bird. Light travels from a rarer medium to a denser medium and bends towards the normal. To the fish, it appears as if the light ray is originating from a position closer than it actually is. Thus, the bird will appear nearer than it actually is.

Of course, if the bird is directly above the fish, the light rays will pass along the normal, there will be no deviation, and the bird and the fish will appear at the position they actually are at to each other.

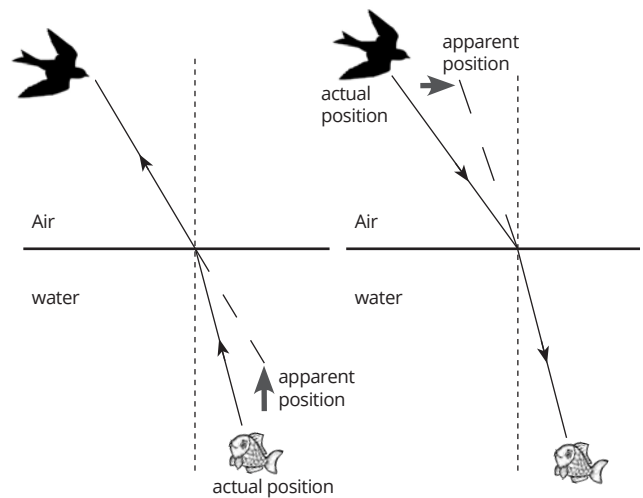

4. If one-half of a convex lens is painted black, will it form the complete image of an object?

Ans. Yes, it will still form the complete image of an object, but the intensity of the image will be lower.

5. When light undergoes refraction at the surface of separation of two media, what happens to its wavelength?

Ans. When light undergoes refraction, its frequency remains constant. Therefore, by the relation $\text{speed} = \text{wavelength} \times \text{frequency}$, the wavelength changes in the same proportion as the speed changes.

6. Can one burn a piece of paper by just using a convex lens instead of a matchstick or any direct flame? Support your answer with the help of an appropriate ray diagram.

Ans. Yes, one can burn a piece of paper by using only a convex lens without a matchstick or any direct flame as long as there is sunlight available.

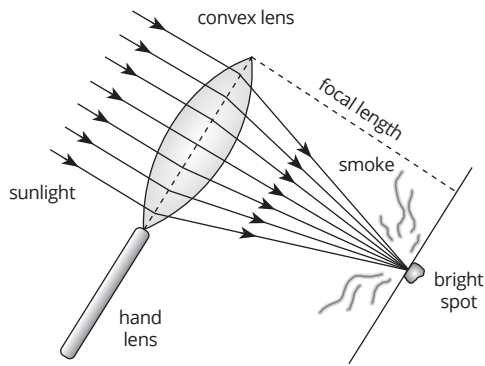

7. Complete the ray diagram in the figure given below in which AB is the object and A'B' is the image. Locate the lens and mark the focus of the lens using the letter F. What type of lens is this?



Ans. Since the image is real, this is a convex lens.

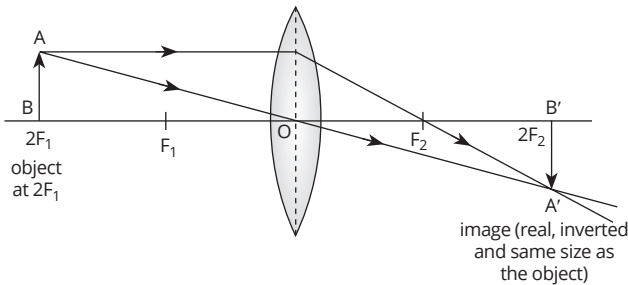

8. The figure given below shows an object AB placed on the principal axis of a lens L. The two foci of the lens are F_1 and F_2 . The image formed by the lens is erect, virtual and diminished.

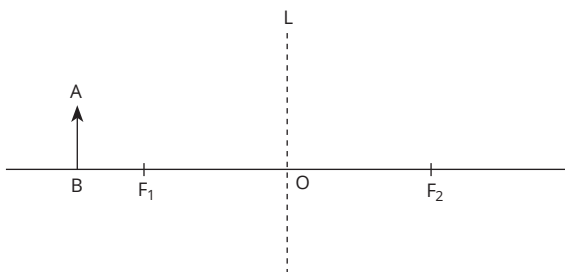

- Draw an outline of the lens L used and name it.
- Draw a ray of light starting from A and passing through O. Show how it emerges after refraction from the lens.
- Draw another ray from A which is incident parallel to the principal axis and show how it emerges after refraction from the lens.

- (d) Locate the final image formed.

Ans. (a) The lens is a concave lens.

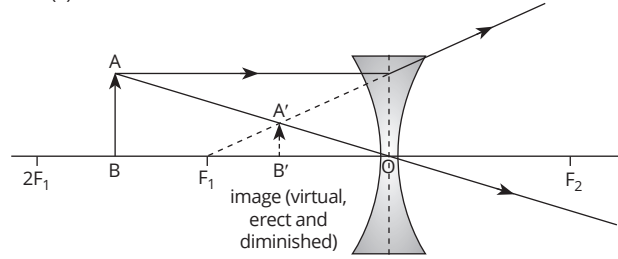

Self-Assessment

(Page 41)

Multiple-Choice Questions

- A ray of light travelling in air falls obliquely on the surface of a calm pond. It will
 - go into the water without deviating from its path.
 - deviate away from the normal.
 - deviate towards the normal.
 - turn back on its original path.

Ans. Since the light ray is passing from an optically rarer medium into a denser medium, it will bend towards the normal. Therefore, the correct answer is (c).

- A ray of light goes from a medium of refractive index n_1 to a medium of refractive index n_2 . The angle of incidence is i and the angle of refraction is r . The, $\frac{\sin i}{\sin r}$ is equal to

- n_1 .
- n_2 .
- $\frac{n_1}{n_2}$.
- $\frac{n_2}{n_1}$.

Ans. The correct answer is (d).

- A lens has a power of +0.5 D. It is
 - a concave lens of focal length 5 m.
 - a convex lens of focal length 5 m.
 - a convex lens of focal length 2 m.
 - a concave lens of focal length 2 m.

Ans. Power = $\frac{1}{f}$ (in m)

$$\text{Therefore, } f = \frac{1}{\text{Power}} = \frac{1}{0.5\text{D}} = 2 \text{ m}$$

The focal length is positive, so it is a convex lens. The correct answer is (c).

- The image formed by a convex lens will be real and inverted unless the object is
 - between F and O.
 - at F.

(c) between F and 2F. (d) cannot say.

Ans. The correct answer is (a).

Assertion–Reason Type Questions

For question numbers 5 to 14, two statements are given – one labelled Assertion (A) and the other labelled Reason (R). Select the correct answer to these questions from the codes (a), (b), (c) and (d) as given below.

- (a) Both A and R are true and R is the correct explanation of the assertion.
- (b) Both A and R are true but R is not the correct explanation of the assertion.
- (c) A is true but R is false.
- (d) A is false but R is true.

5. Assertion: When light travels from one medium to another, its speed changes.

Reason: When light travels from one medium to another, its frequency remains the same.

Ans. (b)

6. Assertion: The refractive index of medium 1 with respect to medium 2 is the reciprocal of the refractive index of medium 2 with respect to medium 1.

Reason: If a refracted ray is reversed in direction, it will retrace its original path.

Ans. (a)

7. Assertion: The refractive index of glass for red light is different from its refractive index for violet light.

Reason: The higher the refractive index of a medium, the more optically dense it is.

Ans. (b)

8. Assertion: Among water, kerosene and glycerine, the refractive index of water is the highest.

Reason: Among water, kerosene and glycerine, the speed of light is the greatest in water.

Ans. (d)

9. Assertion: A concave lens is also known as a negative lens.

Reason: A concave lens can only produce virtual images.

Ans. (b)

10. Assertion: The lens used in a magnifying glass is a convex lens.

Reason: A virtual, erect and highly enlarged image is obtained when the object is placed at the focus of a convex lens.

Ans. (c)

11. Assertion: A convex lens is used in a burning glass.

Reason: A convex lens converges rays from a

distant object onto a small point.

Ans. (a)

12. Assertion: A film and slide projector uses a concave lens.

Reason: The image required in a film and slide projector has to be real and enlarged.

Ans. (d)

13. Assertion: The image distance is always negative for a concave lens according to the New Cartesian Sign Convention.

Reason: The image in a concave lens is always virtual and formed on the same side as the object.

Ans. (a)

14. Assertion: The formula for magnification (m) for a lens can also be written as $m = \frac{f}{f+u}$, where f and u are focal length and object distance, respectively.

Reason: The lens formula is given as $\frac{1}{f} = \frac{1}{v} + \frac{1}{u}$, where f , v and u are focal length, image distance and object distance, respectively.

Ans. (c)

Source-based/Case-based/Passage-based/Integrated Questions

Answer the questions on the basis of your understanding of the following paragraphs and the related studied concepts.

15. Focal length, usually given in mm, is the fundamental description of a camera lens. The focal length is not the actual length of the lens but the optimal distance of the lens from the point where light rays converge to form a sharp image of an object on the digital sensor or 35 mm film at the focal plane of the camera. The focal length of a lens is determined when the lens is focused at infinity. There are two types of lenses, prime and zoom. While the zoom lens allows the benefit of a range of focal lengths, prime lenses have fixed focal lengths and higher apertures, which is an advantage in certain conditions.



- I. (a) What kind of spherical lens is used as the prime lens in a camera? For this lens, if it is focused at infinity, what is the nature and size of the image formed on the digital sensor?
- (b) Why is a large aperture advantageous in dark conditions?
- (c) For a camera prime lens of focal length 52 mm, if the object distance is 2.45 m, what is the image distance?
- (d) All other conditions being the same, will the magnification increase or decrease in the above camera if the focal length was decreased?

- Ans.** (a) Convex lens; Real, inverted, highly diminished
 (b) Clearer images because more light falls on the lens
 (c) 53.1 mm
 (d) Decrease

- II. (a) The maximum portion of the spherical surfaces from which refraction takes place is called the
- focal length of the lens.
 - aperture of the lens.
 - focus of the lens.
 - optical centre of the lens.

Ans. (ii) aperture of the lens.

- (b) Which lens is used in a camera?
- Concave lens
 - Convex lens
 - Plano-concave lens
 - None of the above

Ans. (ii) Convex lens

- (c) Where is the object placed to get an image from a camera?
- Between infinity and $2F$
 - At focus
 - At $2F$
 - Between F and optical centre

Ans. (i) Between infinity and $2F$

- (d) Which type of image is formed by a photographic camera?
- Small in size
 - Real
 - Inverted
 - All of the above

Ans. (iv) All of the above

- (e) Which one of the following materials cannot be used to make a lens?
- Glass
 - Clay
 - Plastic
 - None of the above

Ans. (ii) Clay

16. While projectors in the market can be quite expensive, a simple projector to enjoy a film projected on a wall with friends can be made easily at home. You will need a shoebox, a large magnifying glass of 4 D power with a plastic handle, a paper cutter, some strong glue, some cardboard, and a smartphone. Remove the handle of the magnifying glass, cut a hole in the side of the shoebox exactly the size of the lens of the glass, and stick the lens on the cut side from the inside so that light from outside can enter the entire lens. Use the cardboard to make a movable stand for the phone in horizontal position. The stand should be able to move easily within the shoebox. Cover the shoebox after placing the phone on the stand, and the projector is ready. The projector will have to be calibrated by moving to and fro to get a clear image on the wall. You will also need an app that flips the movie vertically on the phone while playing.



- I. (a) What kind of spherical lens is used in this projector? Why is the app to flip the film vertically needed?
- (b) What is the focal length of the lens used in the project?
- (c) For this lens, how long should the shoebox at least be for the projector to work?
- 5 cm
 - 25 cm
 - 50 cm
 - 100 cm
- (d) If the phone is at 30 cm from the lens in the above projector, what is the magnification of the film on the wall?
- 20 times
 - 5 times
 - 4 times
 - 2 times

- Ans.** (a) Convex lens; because the image formed is inverted.
 (b) 25 cm
 (c) (ii) 25 cm
 (d) (iv) 2 times

- II. (a) A lens thicker in the middle and thinner at the edges is
- concave lens.
 - convex lens.
 - plano-concave lens.
 - none of the above.

Ans. (ii) convex lens.

- (b) Which type of lens is used in magnifying glass?
- Convex lens
 - Concave lens
 - Both concave and convex lenses
 - None of the above

Ans. (i) Convex lens

- (c) In a projector, an object is placed between F_1 and $2F_1$ of a convex lens. Which of the following statements correctly describes its image?
- Enlarged, virtual and erect
 - Enlarged, real and inverted
 - Diminished, virtual and erect
 - Diminished, real and inverted

Ans. (ii) Enlarged, real and inverted

- (d) A magnifying glass is also known as
- projector.
 - camera.
 - simple microscope.
 - terrestrial telescope.

Ans. (iii) simple microscope.

- (e) To obtain a magnification of -0.5 with a convex lens, where should the object be placed?
- At F
 - Between optical centre and F
 - Beyond $2F$
 - None of the above

Ans. (iii) Beyond $2F$

Very Short Answer Type Questions

17. The power of a lens used in the reading glasses of a person is $+1.5$ D. Is the lens concave or convex?

Ans. Since the power has a positive sign, the focal length also has a positive sign. Therefore, it is a convex lens.

18. Refractive indices of glass, kerosene and water are 1.5, 1.44 and 1.33, respectively. Arrange the three substances in increasing order of optical density.

Ans. The lower the refractive index, the lower is its optical density. Therefore, the correct ascending order is water < kerosene < glass in terms of optical density.

19. If a light ray IM is incident on the surface AB of a glass slab $ABCD$ as shown in the following figure,

identify the correct emergent ray from NP , NQ and NR . Give a reason for your choice.

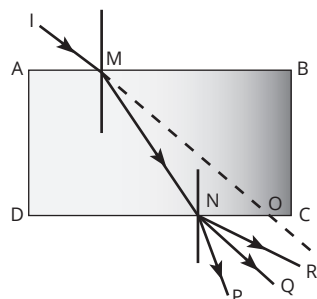

Ans. When a light ray passes through a rectangular glass slab, the emergent ray is parallel to the incident ray. Therefore, the correct emergent ray in this case has to be NQ .

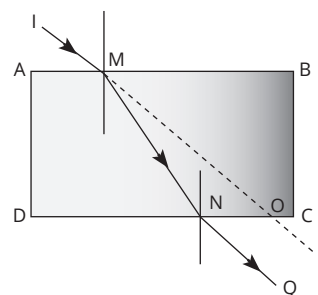

20. In the figure given below, complete the path of the ray incident on the lens.

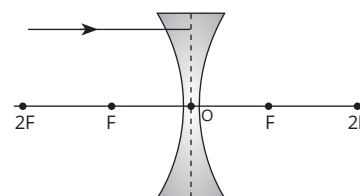

Ans. Since the ray is travelling parallel to the principal axis of the lens, it diverges from its path after passing through the lens such that it appears to originate from the focus as shown in the figure below:

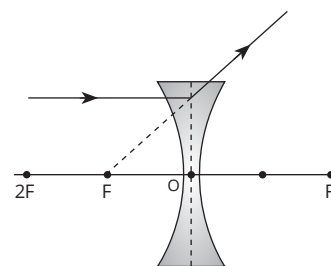

Short Answer Type-I Questions

21. With respect to air, the refractive indices of ice and rock salt are 1.31 and 1.54, respectively.

Calculate the refractive index of rock salt with respect to ice.

Ans. Refractive index of ice with respect to air

$$= \frac{\text{speed of light in air}}{\text{speed of light in ice}} \quad (\text{i})$$

Refractive index of rock salt with respect to air

$$= \frac{\text{speed of light in air}}{\text{speed of light in rock salt}} \quad (\text{ii})$$

Dividing equation (ii) by equation (i),

$$\frac{\text{Refractive index of rock salt with respect to air}}{\text{Refractive index of ice with respect to air}}$$

$$= \frac{\text{speed of light in ice}}{\text{speed of light in rock salt}}$$

= Refractive index of rock salt with respect to ice
or Refractive index of rock salt with respect to ice

$$= \frac{1.54}{1.31} = 1.18$$

22. Copy the figure given below and show the formation of image. What is the type of lens used in the figure? What is the type of image formed?

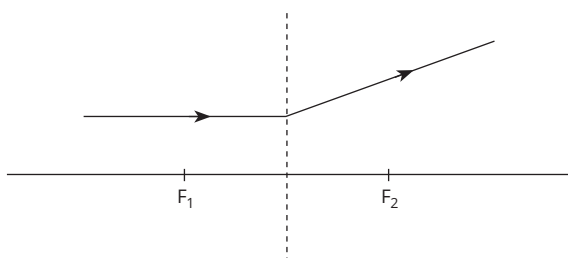

Ans. The lens used in the figure is a concave lens. The image formed is a virtual, erect, and diminished image.

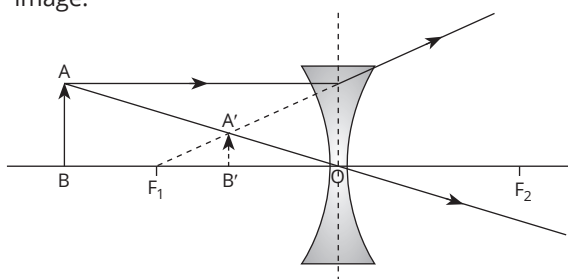

23. A tank of water is 4 m deep. How deep does it appear when seen normally?

Ans. Real depth/apparent depth = absolute refractive index of the medium

$$\text{or } \frac{4 \text{ m}}{\text{apparent depth}} = 1.33$$

$$\text{or } \text{apparent depth} = \frac{4}{1.33} = 3 \text{ m}$$

Therefore, the tank appears to be 3 m deep.

24. An object is placed at a distance of 10 cm from a concave lens of focal length 20 cm. Find the position of the image and discuss its nature.

Ans. Given, $u = -10 \text{ cm}$, $f = -20 \text{ cm}$

Using lens formula,

$$\frac{-1}{20} = \frac{1}{v} - \frac{1}{-10}$$

$$\text{or } \frac{1}{v} = \frac{-1}{20} - \frac{1}{10} = \frac{-3}{20}$$

$$\text{or } v = -6.67 \text{ cm}$$

Therefore, the image is a virtual, erect, and diminished image formed 6.67 cm from the lens on the same side as the object.

Short Answer Type-II Questions

25. A concave lens made of a material of refractive index n_1 is kept in a medium of refractive index n_2 . A parallel beam of light is incident on the lens. Complete the path of rays of light emerging from the concave lens if (a) $n_1 > n_2$, (b) $n_1 = n_2$, and (c) $n_1 < n_2$.

Ans. (a) When $n_1 > n_2$, light goes from a rarer to a denser medium. Therefore, on passing through a concave lens, it diverges.

(b) When $n_1 = n_2$, there is no change in medium. Therefore, no bending or refraction occurs.

(c) When $n_1 < n_2$, light goes from a denser to a rarer medium. Therefore, on passing through a concave lens, it converges.

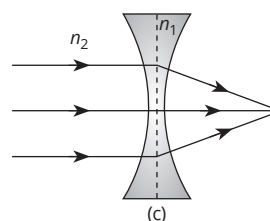
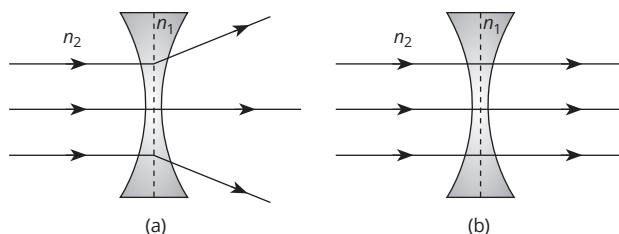

26. The focal length of a convex lens is f . How does the size of the image placed in front of it change as the object is brought progressively closer to the focus from a distance that is just greater than $2f$?

Ans. The size of the image grows as the object is brought towards the focus from a point just beyond $2f$. When the object is beyond $2f$, the image size is smaller than the object size. When

the object is at $2f$, the image size is the same as the object size. When the object is between f and $2f$, the image size is greater than the object size.

27. A converging lens is to project 4 times enlarged image of a lamp on a wall at a distance of 10 cm from the lamp. Find the focal length of the lens.

Ans. For a convex lens, the sign of the object is negative and the sign of a real image is positive. Also, the image is 4 times the size of the object. The distance of the image from the object is 10 cm

$$\text{or } |v| + |u| = 10$$

$$\text{or } |4u| + |u| = 10$$

$$\text{or } |u| = 2 \text{ and } |v| = 8$$

Using lens formula,

$$\frac{1}{f} = \frac{1}{8} - \frac{1}{-2} = \frac{5}{8} = \frac{1}{1.6}$$

$$\text{or } f = +1.6 \text{ cm}$$

28. An object is placed at a distance of 50 cm from a converging lens of power +4 D. Find the position, nature and magnification of image.

Ans. Power = +4 D, $u = -50$ cm

$$\text{Power} = \frac{1}{f} \text{ (in m)}$$

$$\text{or } f = \frac{1}{4D} = 0.25 \text{ m} = 25 \text{ cm}$$

Using lens formula,

$$\frac{1}{25} = \frac{1}{v} - \frac{1}{-50} = \frac{1}{v} + \frac{1}{50}$$

$$\text{or } \frac{1}{v} = \frac{1}{25} - \frac{1}{50} = \frac{1}{50}$$

$$\text{or } v = 50 \text{ cm}$$

$$m = \frac{v}{u} = \frac{50}{-50} = -1$$

Therefore, the image is a real and inverted image of the same size as the object formed at 50 cm from the lens on the side opposite to that of the object.

Long Answer Type Questions

29. A convex lens of focal length 18 cm and a concave lens of focal length 24 cm are placed in contact such that they have a common principal axis. Will the combination act as a convex lens or a concave lens? Find the focal length and power of the combination.

Ans. Power of convex lens, $P_1 = \frac{1}{0.18}$ D

$$\text{Power of concave lens, } P_2 = \frac{-1}{0.24} \text{ D}$$

Power of the combination,

$$\begin{aligned} P &= P_1 + P_2 \\ &= \frac{1}{0.18} \text{ D} - \frac{1}{0.24} \text{ D} \\ &= \frac{1}{0.72} \text{ D} = 1.39 \text{ D} \end{aligned}$$

Since the power is positive, the combination behaves like a convex lens

Also, focal length of the combination

$$= \frac{1}{P} = 0.72 \text{ m} = 72 \text{ cm}$$

30. (a) When an object is placed at a distance of 10 cm from a convex lens, its virtual image, twice as big as the object, is formed. Calculate the focal length of the lens.
(b) Where should the object be placed in front of the same lens so as to form its real image of twice the size?

Ans. (a) $u = -10$ cm, $v = 2u = -20$ cm

Using lens formula,

$$\frac{1}{f} = \frac{1}{-20} - \frac{1}{-10} = \frac{1}{20}$$

$$\text{or } f = 20 \text{ cm}$$

- (b) For image to be real, if $u = -x$ cm, $v = 2x$ cm

Using lens formula,

$$\frac{1}{20} = \frac{1}{2x} - \frac{1}{-x} = \frac{1}{2x} + \frac{1}{x} = \frac{3}{2x}$$

$$\text{or } x = 30 \text{ cm}$$

Therefore, the object should be placed 30 cm from the lens (i.e. $u = -30$ cm)

Let's Compete

(Page 44)

Multiple-Choice Questions

1. When two lenses are placed in contact, the property that can be added algebraically is
(a) focal length. (b) power.
(c) aperture. (d) radius of curvature.

Ans. The correct answer is (b).

2. The image formed by a concave lens is always
(a) magnified.
(b) highly enlarged.
(c) of the same size as the object.
(d) diminished.

Ans. The correct answer is (d).

3. Which of these is an application of a convex lens where the image is present beyond $2F_1$?

- (a) Magnifying glass (b) Searchlight
(c) Photographic camera (d) Terrestrial telescope

Ans. The correct answer is (c).

4. When two transparent media are compared, the one with a higher refractive index is termed optically

- (a) rarer. (b) fast.
(c) denser. (d) none of these.

Ans. The correct answer is (c).

5. If while moving from medium A to medium B, an incident ray of light makes an angle of 45° with the normal and the refracted ray makes 60° with the horizontal surface separating A from B, the refractive index of B with respect to A is

- (a) $\sqrt{2}$. (b) $\frac{1}{\sqrt{2}}$.
(c) $\frac{\sqrt{3}}{2}$. (d) $\frac{\sqrt{2}}{3}$.

Ans. The refracted ray makes an angle of 60° with the horizontal surface. So, the angle of refraction is $90^\circ - 60^\circ = 30^\circ$. Angle of incidence is given to be 45° . Refractive index of B with respect to A

$$= \frac{\sin i}{\sin r} = \frac{\sin 45^\circ}{\sin 30^\circ} = \frac{\frac{1}{\sqrt{2}}}{\frac{1}{2}} = \sqrt{2}. \text{ Therefore, the}$$

correct answer is (a).

6. Refractive index of a medium is $4/3$. The speed of light in the medium has a value

- (a) 3×10^8 m/s. (b) 2×10^8 m/s.
(c) 2.25×10^8 m/s. (d) 4×10^8 m/s.

Ans. Refractive index of a medium

$$= \frac{\text{speed of light in air}}{\text{speed of light in that medium}}$$

or Speed of light in that medium

$$= \frac{\text{speed of light in air}}{\text{refractive index of the medium}}$$

$$= \frac{3 \times 10^8 \text{ m/s}}{\left(\frac{4}{3}\right)} = 2.25 \times 10^8 \text{ m/s.}$$

Therefore, the correct answer is (c).

7. An object is placed at a distance of 20 cm from a convex lens and its real and inverted image of same size is formed on a screen placed on the other side of the lens. The focal length of the lens is

- (a) 10 cm. (b) 20 cm.
(c) 5 cm. (d) 40 cm.

Ans. $u = -20$ cm, $v = 20$ cm

$$\frac{1}{f} = \frac{1}{20} - \frac{1}{-20} = \frac{1}{10}$$

or $f = 10$ cm

Therefore, the correct answer is (a).

8. Focal length of a convex lens is 20 cm. Its power is

- (a) +5 D. (b) -5 D.
(c) +0.05 D. (d) -0.05 D.

Ans. $P = \frac{1}{f}$ (in m) = $\frac{1}{0.2} = 5$ D. Therefore, the correct answer is (a).

9. In the determination of focal length of a convex lens, image of grill of a window is formed on a screen. The index mark of screen holder is 37.5 cm and that of lens holder is 16.2 cm. The distance of grill from the lens is 2.5 m. Focal length of lens is

- (a) 2.5 m. (b) 37.5 cm.
(c) 16.2 cm. (d) 21.3 cm.

Ans. This experiment is similar to the experiment where the focal length of a convex lens is determined by focusing sunrays. The distance of the image from the lens is equal to the focal length of the lens. In this case, the image is formed on the screen, which is at mark 37.5 cm on a scale. The lens is at mark 16.2 cm on the scale. Thus, the distance between the screen and the lens is $37.5 \text{ cm} - 16.2 \text{ cm} = 21.3 \text{ cm}$. Therefore, the correct answer is (d).

10. In the above question, in order to obtain a sharp image of a grill, we can move

- (a) screen holder only.
(b) lens holder only.
(c) both screen holder and lens holder.
(d) neither screen holder nor lens holder.

Ans. The correct answer is (c).

Value-based Questions (Optional) (Page 45)

1. Anushka was walking around a pool of water. The pool appeared shallow to her, so she took a dive in it. It was actually a deep pool and she started shouting for help to get her out of the pool. Her friend, Virat, who was passing by, immediately dived into the pool and saved Anushka.
- (a) Why does a pool of water appear less deep than it actually is?
(b) What values are shown by Virat?

Ans. (a) A pool of water appear less deep than it actually is because the light rays travelling from the water to air bend away from the normal due to refraction making it appear that they are originating from points higher than they actually are.

(b) Bravery, confidence in one's own abilities, concern for another person

2. Murtaza, a class V student, wanted to make something really impressive for his science exhibition. He was sitting worried when his elder sister, Benazir, who was in class X, suggested that he could build a simple terrestrial telescope. Murtaza liked the idea and Benazir helped him in building the telescope.

(a) Show the image formation in a terrestrial telescope using a ray diagram.

(b) What values are shown by Benazir in the above scenario?

Ans. (a)

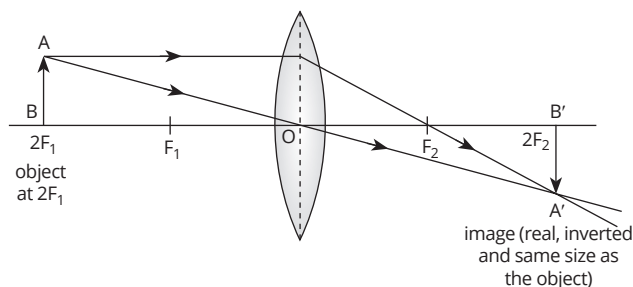

(b) Consideration for younger sibling, practical application of concepts learnt in classroom

3. Kriti had a few convex and concave lenses with her, which she ended up mixing together by mistake. She wanted to keep them in separate packets and label them. She sought Harpreet's help, who was able to distinguish between the convex and concave lenses in the mixture without even touching them.

(a) How was Harpreet able to separate the convex lenses from the concave lenses without touching them?

(b) What values are shown by Harpreet?

Ans. (a) By looking through them. Concave lenses always create erect images, while convex lenses generally create inverted images, except when the object is between O and F_1 .

(b) Willingness to help friends, practical application of concepts learned in classroom

The Human Eye and the Colourful World

Checkpoint _____ (Page 48)

1. How many colours is white light made up of?

- (a) 1 (b) 33
(c) 7 (d) 9

Ans. The correct answer is (c).

2. There are no sensory cells present at the junction of the retina and the optic nerve in the human eye, so no vision is possible here. This part of the eye is called the

- (a) blank spot. (b) blind spot.
(c) vacant spot. (d) null spot.

Ans. The correct answer is (b).

3. Which of these parts of the eye controls the size of the pupil and hence the amount of light entering the eye?

- (a) Retina (b) Cornea
(c) Optic nerve (d) Iris

Ans. The correct answer is (d).

4. The image formed by a convex lens when the object is placed at the focus is

- (a) real, inverted and highly enlarged.
(b) virtual, erect and highly enlarged.
(c) real, erect and diminished.
(d) virtual, inverted and diminished.

Ans. The correct answer is (a).

5. What process does light undergo inside a kaleidoscope?

- (a) Multiple reflections
(b) Multiple refractions

(c) A reflection followed by a refraction

(d) A refraction followed by a reflection

Ans. The correct answer is (a).

6. White light can be broken into its constituent colours using a prism. But is it possible to mix these constituent colours to obtain white light in laboratory conditions?

Ans. Yes, it is possible to mix the seven constituent colours to obtain white light in laboratory conditions.

7. For a convex lens of focal length 15 cm, find the distance at which the image is formed if the object is placed 30 cm from the lens.

Ans. Given, $f = 15$ cm, $u = -30$ cm

Using the lens formula, we have

$$\frac{1}{15} = \frac{1}{v} - \frac{1}{(-30)}$$

or
$$\frac{1}{v} = \frac{1}{30}$$

Therefore, the image is formed 30 cm on the other side of the lens.

8. When a light ray enters a glass slab from air and then passes out into air, what is the angle between the emergent ray and the incident ray?

Ans. Since the incident ray and the emergent ray are parallel in such a case, the angle between them is 0° .

9. In the colours of a rainbow, if red has the maximum wavelength, which colour has the least wavelength?

Ans. If red has the maximum wavelength, the least wavelength would be for the colour at the opposite end of the spectrum, which is violet.

10. What is the slowest rate at which still images of a moving object can be flashed on the human eye for the eye to perceive the object as moving?

Ans. The slowest rate is 16 images per second.

———— Milestone 1 ————

(Page 53)

Multiple-Choice Questions

1. The change of focal length of an eye lens is caused by the action of the
- (a) pupil. (b) retina.
(c) ciliary muscles. (d) iris.

Ans. The correct answer is (c).

2. Which of these are likely to be found in the spectacles of a person suffering from myopia?
- (a) Concave lens (b) Concave mirror
(c) Convex lens (d) Convex mirror

Ans. The correct answer is (a).

3. When the eye is focused on an object very far away, the focal length of the eye lens is
- (a) maximum.
(b) minimum.
(c) equal to that of the crystalline lens.
(d) optic nerve.

Ans. The correct answer is (a).

4. A parallel beam of light falling on the eye gets focused on the retina because of refractions at
- (a) the cornea.
(b) the crystalline lens.
(c) the vitreous humour.
(d) various surfaces in the eye.

Ans. The correct answer is (d).

5. When light rays are incident on the eye, the maximum deviation takes place at the
- (a) retina. (b) iris.
(c) vitreous humour. (d) cornea.

Ans. The correct answer is (d).

6. Decrease in the size of the eye lens is a cause of
- (a) myopia. (b) hypermetropia.
(c) colour blindness. (d) cataract.

Ans. The correct answer is (b).

Very Short Answer Type Questions

7. Why does excessive curvature of the eye cause myopia?

Ans. Excessive curvature decreases the focal length of the eye lens, which forms images in front of the

retina. This makes it difficult to look at distance objects.

8. How is it possible to correct eye defects these days without using spectacles?

Ans. Laser eye surgery is used these days to correct certain eye defects like myopia and hypermetropia.

9. What kind of lens does the human eye have?

Ans. The human eye has a double convex lens.

10. A person needs a lens of power +2 D for correcting his near vision. What is the focal length of the lens required?

Ans. We know that power of a lens = $\frac{1}{f}$, where f is the focal length of the lens in metres

$$\text{Therefore, } +2 \text{ D} = \frac{1}{f}$$

$$\begin{aligned} \text{or } f &= \frac{1}{2} \text{ m} \\ &= 0.5 \text{ m} \\ &= 50 \text{ cm} \end{aligned}$$

Short Answer Type-I Questions

11. Why is a normal eye not able to see clearly the objects placed closer than 25 cm?

Ans. If an object is placed closer than 25 cm, the lens of the normal human eye cannot curve enough to focus the image on the retina. This is why 25 cm is considered the near point of the eye or the minimum distance at which objects can be seen clearly without strain.

12. Compute the power of lens required to correct a hypermetropic eye with its near point at 75 cm from the eye.

Ans. The near point for the normal eye is 25 cm, while the hypermetropic eye in the question has a near point of 75 cm. We need a convex lens to correct the hypermetropic eye.

$$\text{Therefore, } u = -25 \text{ cm, } v = -75 \text{ cm}$$

Using the lens formula,

$$\frac{1}{f} = \frac{1}{(-75)} - \frac{1}{(-25)}$$

$$\text{or } \frac{1}{f} = \frac{2}{75}$$

$$\text{or } f = \frac{75}{2} \text{ cm} = \frac{0.75}{2} \text{ m}$$

$$\text{Power of the lens} = \frac{1}{f} \text{ (in m)}$$

$$= \frac{2}{0.75} = 2.67 \text{ D}$$

13. Name the defect of vision that arises due to gradual weakening of the ciliary muscles in old age. What type of lenses is required by the person suffering from this defect to see objects clearly?

Ans. The defect of vision that arises due to the gradual weakening of the ciliary muscles in old age is presbyopia. It can be corrected with the use of spectacles with a convex lens.

Short Answer Type-II Questions

14. What is the function of each of the following parts of an eye?

- Sclerotic
- Choroid
- Retina
- Cones
- Optic nerve

Ans. (a) Sclerotic – It is the outermost covering of the eye that protects the vital internal parts of the organ.

(b) Choroid – This dark pigmented membranous layer darkens the eye from inside and prevents any internal reflection.

(c) Retina – This is the innermost delicate membrane of the eye where the image of an object is formed. It also has cells called cones and rods that make the eye sensitive to colour and light intensity, respectively.

(d) Cones – Cones are cells that help the eye detect different colours.

(e) Optic nerve – It is composed of about one million nerve fibres that carry the signals from the eye to the brain.

15. An object of size 2 cm is placed at a point 25 cm away from the eye. Its image is formed on the retina, which is 2.5 cm behind the eye lens. Find the size of the image.

Ans. The lens in the eye is a double convex lens and the image formed is a real image.

Thus, $u = -25$ cm, $v = 2.5$ cm

$$h = 2 \text{ cm}$$

Using the formula, $\frac{h'}{h} = \frac{v}{u}$, we have

$$\frac{h'}{(2 \text{ cm})} = \frac{2.5 \text{ cm}}{(-25 \text{ cm})} = \frac{-1}{10}$$

or $h' = -0.2$ cm

Therefore, an inverted image of size 0.2 cm is formed.

16. Find the nature, focal length and power of lens required for the spectacles of two friends A and B whose eye defects are explained below:

(a) A can see clearly up to a distance of 30 cm.

He wants to read a book kept at a distance of 40 cm.

- (b) B is unable to see objects nearer than 150 cm. He wants to read a book placed at a distance of 25 cm.

Ans. (a) A is unable to see distant objects clearly, so he suffers from myopia and needs a concave lens to correct the problem.

Given, $u = -30$ cm, $v = -40$ cm

Using lens formula,

$$\frac{1}{f} = \frac{1}{(-40 \text{ cm})} - \frac{1}{(-30 \text{ cm})}$$

$$= \frac{1}{120 \text{ cm}}$$

or $f = 120$ cm

$$P = \frac{1}{f} \text{ (in m)}$$

$$= \frac{1}{(1.2)}$$

$$= 0.83 \text{ D}$$

- (b) B has difficulty in seeing nearby objects, so he suffers from hypermetropia and needs convex lens to correct the problem.

Given, $u = -25$ cm, $v = -150$ cm

Using lens formula,

$$\frac{1}{f} = \frac{1}{(-150 \text{ cm})} - \frac{1}{(-25 \text{ cm})}$$

or $f = 30$ cm

$$\text{Power} = \frac{1}{0.3} = 3.33 \text{ D}$$

Long Answer Type Questions

17. Draw a labelled diagram of the human eye.

Ans.

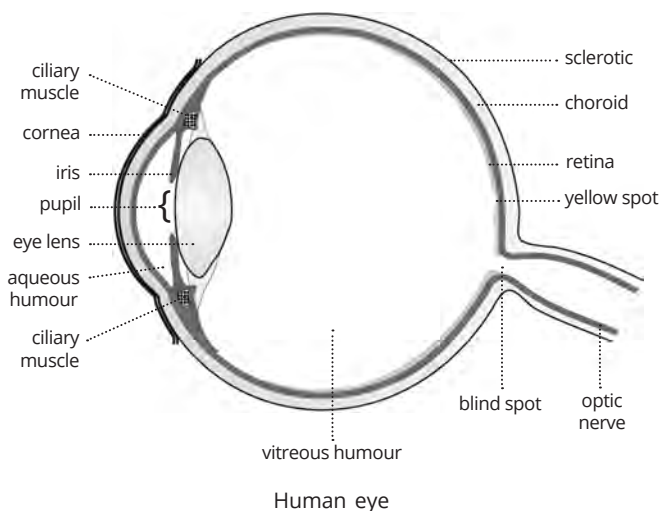

18. Draw diagrams to show the change in image formation brought about in the human eye in case of hypermetropia by the use of the right corrective lens.

Ans.

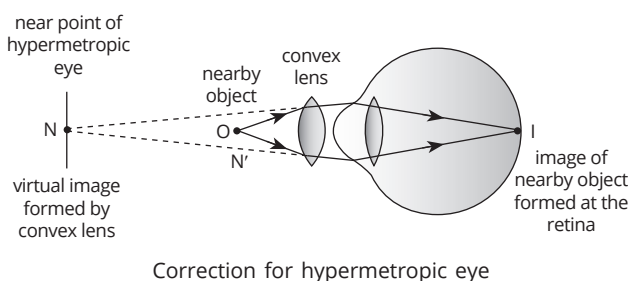

Correction for hypermetropic eye

Milestone 2

(Page 58)

Multiple-Choice Questions

1. The number of surfaces bounding a prism is

(a) 3. (b) 4.
(c) 5. (d) 6.

Ans. A prism has three rectangular bases and two triangular sides. Therefore, the correct answer is (c).

2. If the earth had no atmosphere, the sky would have looked

(a) red. (b) blue.
(c) yellow. (d) dark.

Ans. The correct answer is (d).

3. The coloured band of light obtained by dispersion of light is called

(a) image. (b) shadow.
(c) spectrum. (d) none of these.

Ans. The correct answer is (c).

4. A deviation in the path of a ray of light can be produced

(a) by a glass prism but not by a rectangular glass slab.
(b) by a rectangular glass slab but not by a glass prism.
(c) by a glass prism as well as a rectangular glass slab.
(d) neither by a glass prism nor by a rectangular glass slab.

Ans. In a rectangular slab, the emergent ray has the same direction as that of the incident ray. So, a deviation in the path of a light ray is not possible. Therefore, the correct option is (a).

5. The colour in the sequence VIBGYOR that has the least wavelength is

(a) violet. (b) red.
(c) blue. (d) yellow.

Ans. The correct answer is (a).

6. Which of these phenomena takes place inside a water droplet when a rainbow is formed?

(a) Total internal refraction
(b) Total internal reflection
(c) Double reflection
(d) Total external reflection

Ans. The correct answer is (b).

Very Short Answer Type Questions

7. When a prism splits white light into seven constituent colours, which colour gets deviated the most?

Ans. A prism causes the greatest deviation in the colour with the lowest wavelength. This colour is violet.

8. Why are true solutions not able to show Tyndall effect?

Ans. True solutions are not able to show Tyndall effect because the particles in true solutions are too small to be able to scatter light.

9. If the angle of incidence and the angle of refraction are denoted by i_1 and r_1 , respectively, for the first refraction in a prism, according to convention how are the angles of incidence and refraction denoted for the second refraction?

Ans. Angle of incidence: r_2 , angle of refraction: i_2

10. Is it necessary that the cross section of a prism be any particular type of triangle, such as an equilateral triangle?

Ans. No, the cross section of a prism can be any type of triangle.

Short Answer Type-I Questions

11. Smoke from a fire looks white. What can you deduce about the size of the particles of ash in it?

Ans. If the smoke from a fire looks white, we can deduce that the ash particles are very large.

12. What is the relation between the wavelength of light and the size of the particle causing scattering?

Ans. Smaller particles scatter light of shorter wavelengths such as blue light. Particles of larger size scatter light of longer wavelengths such as red light. If the size of the scattering particles is large enough, then the scattered light appears white.

13. What makes particles in a smoke-filled room or particles in the earth's atmosphere become visible? What is this phenomenon called?

Ans. Particles in a smoke-filled room or in the earth's atmosphere become visible because they scatter the light falling on them. This phenomenon is called Tyndall effect.

Short Answer Type-II Questions

14. How can we recombine the components of white light after a prism has separated them? Draw a diagram to illustrate it.

Ans. The components of white light can be recombined after a prism has separated them by placing a second prism next to the first prism in an inverted position.

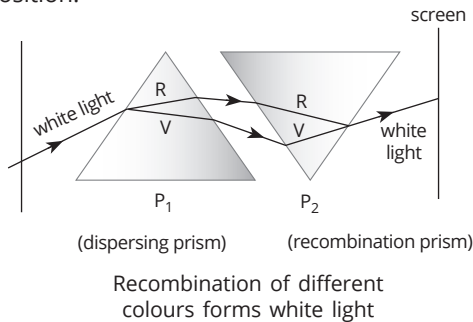

15. What is atmospheric refraction? Use this phenomenon to explain the following natural events.

- (a) Twinkling of stars
- (b) Stars appearing higher than they actually are

Ans. When light rays pass through the atmosphere that has layers of different densities and refractive indices, refraction of the rays takes place. This is called atmospheric refraction.

- (a) When the light from stars enters the atmosphere, it gets refracted by varying amounts and in different directions from one moment to the next because of the different layers in the atmosphere. This causes a constant change in the intensity of the light reaching the earth's surface, making it appear as if the stars are twinkling.
- (b) The light from the stars travels from a rare medium into the denser medium of the atmosphere. It gets refracted towards the earth's surface, making it appear as if it is coming from a greater height than it actually is. This is why, stars appear to be higher than they actually are.

Long Answer Type Questions

16. Draw a ray diagram to show the refraction of light by a glass prism. In this diagram, label the following:

- (a) incident ray
- (b) angle of incidence
- (c) angle of refraction
- (d) emergent ray
- (e) angle of emergence
- (f) angle of deviation

Ans.

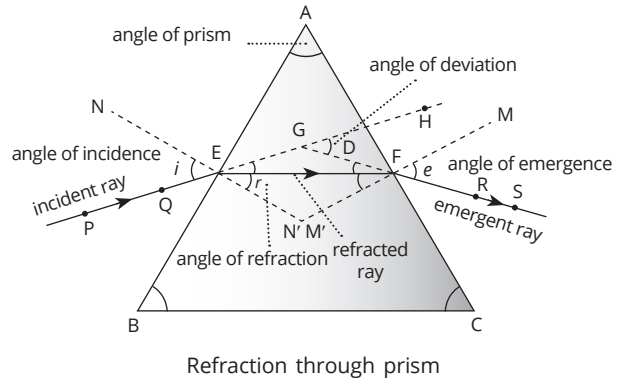

17. Draw a ray diagram to show the formation of rainbow and mark the point where (a) dispersion and (b) internal reflection occur.

Ans.

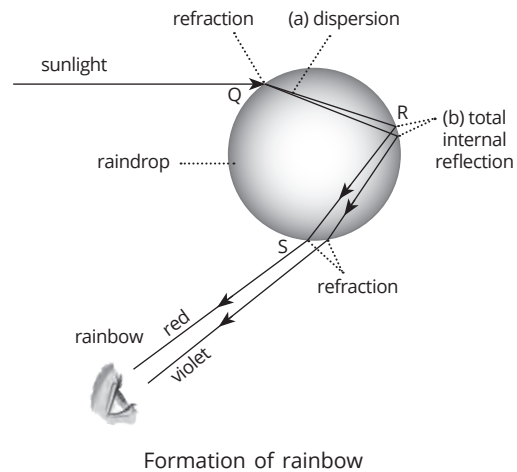

Higher Order Thinking Skills (HOTS) Questions

(Page 60)

1. A convex lens made of glass forms a sharp image on the screen for a particular position of an object with respect to the lens. A human eye is also a convex lens, but it can form sharp images on the retina of the eye for different positions of objects. Explain how.

Ans. A convex lens made of glass has a fixed value of focal length. Hence, it can form a sharp image on

the screen for a particular position of an object only. On the other hand, the focal length of the eye lens can be changed or adjusted easily due to the property of accommodation, and, as a result, the eye lens can form sharp images on the retina for different positions of objects.

2. In the diagram given below, what is the defect of vision depicted?

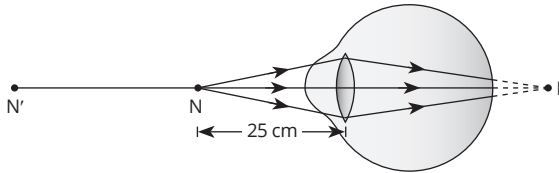

Ans. The diagram shows that the image of an object situated at 25 cm from the eye is formed behind the retina. Therefore, the defect depicted here is hypermetropia.

3. A star appears to be just above the horizon. What is the true position of the star? Explain with the help of a diagram.

Ans. The true position of the star is just below the horizon. It is because of atmospheric refraction that it appears to be slightly higher than it actually is. The figure below shows how a star at position S appears to be at position S' in the sky.

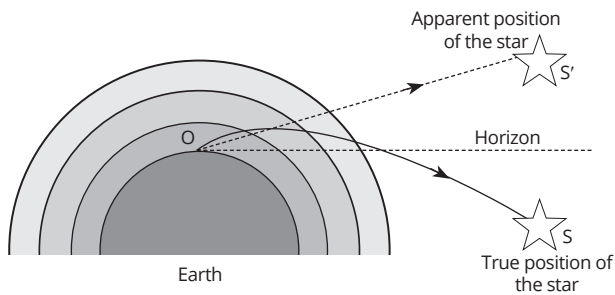

4. When the object distance from the eye is increased, what happens to the image distance? Explain why.

Ans. There is no change in the image distance as it is always formed at the retina. It's only the focal length that gets adjusted depending on the position of the object.

5. For which colour - violet or green - does glass have greater refractive index?

Ans. The shorter the wavelength, the higher is the refractive index. Therefore, the refractive index for violet is greater in glass than for green.

6. Why does a properly cut diamond shine more than a similarly cut piece of glass?

Ans. Diamond has a higher refractive index than glass and, hence, disperses more light than glass does. This is why, a piece of diamond shines more than a similarly cut piece of glass.

Self-Assessment

(Page 60)

Multiple-Choice Questions

1. The human eye is more or less like a
 (a) microscope. (b) telescope.
 (c) photographic camera. (d) none of these.

Ans. The correct answer is (c). The similarities between the human eye and a photographic camera include the presence of a diaphragm to control the amount of eye that gets through to the lens, a convex lens to focus the light, and the formation of an inverted image on a light-sensitive surface.

2. The property of the human eye that is used in cinematography is
 (a) persistence of vision.
 (b) power of accommodation.
 (c) colour blindness.
 (d) range of vision.

Ans. The correct answer is (a). Persistence of vision makes a series of still images seem like a running film to our eye. This is the principle of cinematography.

3. How many times does a ray of light bend on passing through a prism?
 (a) Once (b) Twice
 (c) Thrice (d) None of these

Ans. The correct answer is (b).

4. Which of these phenomena is not explained by scattering of light?
 (a) Red colour of danger signals
 (b) Blue colour of the sky
 (c) White colour of the clouds
 (d) Advanced sunrise

Ans. Out of the four phenomena, advanced sunrise is explained by atmospheric refraction. Therefore, the correct answer is (d).

5. Which of the following phenomenon of light are involved in the formation of a rainbow?
 (a) Reflection, refraction and dispersion
 (b) Refraction, dispersion and internal reflection
 (c) Dispersion, scattering and internal reflection
 (d) Refraction, dispersion and scattering

Ans. The correct answer is (b).

Assertion-Reason Type Questions

For question numbers 6 to 15, two statements are given – one labelled Assertion (A) and the other labelled Reason (R). Select the correct answer to these questions from the codes (a), (b), (c) and (d) as given below.

- (a) Both A and R are true and R is the correct explanation of the assertion.
- (b) Both A and R are true but R is not the correct explanation of the assertion.
- (c) A is true but R is false.
- (d) A is false but R is true.

6. **Assertion:** Cats and dogs cannot see as many colours as humans can but see better in the dark than human can.

Reason: Cats and dogs have fewer types of cones and more rods in their retinas than humans.

Ans. (a)

7. **Assertion:** The pupil in the human eye contracts when the light is intense and dilates when it is not.

Reason: The retina in the human eye has muscles that regulate the amount of light entering the eye.

Ans. (c)

8. **Assertion:** The human eye has the ability to observe objects located anywhere from about 25 cm to a large distance distinctly.

Reason: The focal length of the eye lens adjusts according to the distance of the object being observed.

Ans. (a)

9. **Assertion:** A person with myopia is not able to see nearby objects clearly.

Reason: In myopia, image of an object is formed in front of the retina instead of at the retina because of decrease in focal length of the eye lens.

Ans. (d)

10. **Assertion:** Old people with presbyopia find it difficult to see nearby objects comfortably.

Reason: Thinning of the eye lens can result in increase of its focal length.

Ans. (b)

11. **Assertion:** The spectrum obtained when white light passes through a glass prism has violet at the bottom and red at the top.

Reason: The refractive index of red is the lowest among the seven colours obtained in a spectrum.

Ans. (a)

12. **Assertion:** Advance sunrise and delayed sunset are caused because of atmospheric refraction.

Reason: When light rays from the sun enter the

earth's atmosphere, they bend away from the normal.

Ans. (c)

13. **Assertion:** All solutions of solid particles dissolved in a liquid exhibit the Tyndall effect.

Reason: Dust particles become visible when a fine beam of sunlight enters a dust-filled room because of the Tyndall effect.

Ans. (d)

14. **Assertion:** The sky appears blue because of scattering of light in the earth's atmosphere.

Reason: Blue light has the shortest wavelength among the seven constituent colours of light; hence, it gets scattered the most.

Ans. (c)

15. **Assertion:** Danger signals are red in colour because red light gets scattered the least.

Reason: Motorists use orange light on a foggy day instead of normal white light.

Ans. (b)

Source-based/Case-based/Passage-based/Integrated Questions

Answer the questions on the basis of your understanding of the following paragraphs and the related studied concepts.

16. The sparkling of diamonds (refractive index = 2.42) is caused partially by a phenomenon called total internal reflection. When light rays pass from one medium to another, some of them get reflected, while others get refracted. When light passes from an optically denser medium to an optically rarer medium, the refracted light moves away from the normal. In some cases, the refraction away from the normal is such that angle of refraction exceeds 90° and the light moves back into the denser medium. This combination of partially reflected rays and partially refracted rays that get refracted back into the original medium is total internal reflection. The smallest angle of incidence that yields total reflection is called the critical angle.



- I. (a) If the refractive index of air is 1.0003, is total internal reflection likely to take place when light moves from a diamond into air or when it moves from air into a diamond?

- (b) To find the critical angle of incidence of diamond, what will be the angle of refraction?
- (c) What is the critical angle of diamond?
- (d) If we were considering red light, would the refractive index of air be lower than 1.0003 or higher?

Ans. (a) From diamond into air

- (b) 90°
 (c) 24.4°
 (d) Lower

II. (a) Which of the following is not due to total internal reflection?

- (i) Brilliance of diamond
 (ii) Mirage on hot summer days
 (iii) Difference between apparent and real depth of a pond
 (iv) Working of optical fibre

Ans. (iii) Difference between apparent and real depth of a pond

(b) Which of the following is a necessary condition for total internal reflection?

- (i) The angle of incidence in the denser medium must be greater than the critical angle for the two media.
 (ii) The angle of incidence in the rarer medium must be greater than the critical angle for the two media.
 (iii) The angle of incidence in the denser medium must be lesser than the critical angle for the two media.
 (iv) The angle of reflection in the denser medium must be greater than the critical angle for the two media.

Ans. (i) The angle of incidence in the denser medium must be greater than the critical angle for the two media.

(c) What is the critical angle of water?

- (i) 42° (ii) 48.75°
 (iii) 24° (iv) 75°

Ans. (ii) 48.75°

(d) Which of the following statements is not correct?

- (i) Air is an optically rarer medium as compared to glass and water.
 (ii) Glass is an optically denser medium than air and water.
 (iii) Water is optically rarer than air but optically denser than glass.
 (iv) Greater the difference in speeds of light in two media, greater will be the deviation in the path of light in the second medium.

Ans. (iii) Water is optically rarer than air but optically denser than glass.

(e) A ray of light passes from a medium A to another medium B. No refraction of light takes place if the ray of light hits the boundary of medium B at an angle of

- (i) 30° (ii) 45°
 (iii) 90° (iv) 105°

Ans. (iii) 90°

17. In optics, the branch of physics that studies the behaviours of light, a diaphragm is a thin opaque structure with an opening (aperture) at the centre. The diaphragm's role is to stop the passage of light, except for the light passing through the aperture. The diaphragm is placed in the light path of a lens or objective, and the size of the aperture regulates the amount of light that passes through the lens. The centre of the diaphragm's aperture coincides with the optical axis of the lens system. In the human eye, mydriasis is a condition where the excitation of the radial muscle fibres attached to the diaphragm causes the aperture to dilate (expand) even when it is not supposed to. It is generally caused due to certain drugs or because of trauma to the nerves in the region.



- I.** (a) What are the names of the diaphragm and the aperture in the human eye?
 (b) In what light conditions is the aperture in the human eye supposed to dilate and when is it supposed to contract?
 (c) What happens to the aperture when focusing on a near object? Does it dilate or contract?
 (d) What is the colour of the aperture in the human eye? Why?

Ans. (a) Iris and pupil, respectively
 (b) Dilate in low light conditions and contract in strong light
 (c) Contract
 (d) Black, as it absorbs almost all light falling on it

II. (a) The branch of Physics that studies the behaviours of light is known as

- (i) mechanics. (ii) statics.
 (iii) optics. (iv) biomechanics.

Ans. (iii) optics.

(b) The opaque diaphragm in the human eye is called the iris. It is located behind the

- (i) cornea. (ii) retina.
- (iii) eye lens. (iv) blind spot.

Ans. (i) cornea.

(c) When the eye looks at near-by objects, the lens becomes

- (i) thinner.
- (ii) thicker.
- (iii) both thinner and thicker.
- (iv) none of the above.

Ans. (ii) thicker.

(d) Which of the following parts of the human eye prevents any internal reflection?

- (i) Sclerotic (ii) Choroid
- (iii) Optic nerve (iv) Pupil

Ans. (ii) Choroid

(e) The size of the pupil of the eye is adjusted by

- (i) cornea. (ii) optic nerve.
- (iii) iris. (iv) ciliary muscles.

Ans. (iii) iris.

Very Short Answer Type Questions

18. Which colour, violet or red, has a greater speed in glass?

Ans. Red has the greater speed in glass compared to violet.

19. What is the nature of the image formed at the retina of the eye by the eye lens?

Ans. The image formed at the retina is real, inverted.

20. How does the thickness of the eye lens change when we shift looking for a distant tree to reading a book?

Ans. The thickness of the eye lens increases when we shift our gaze from a distant object to a nearby object as the focal length has to be shorter.

21. A person is able to see objects clearly only when these are lying at distances between 50 cm and 300 cm from his eyes. What is the problem with his vision?

Ans. The person is suffering from both myopia and hypermetropia.

22. Why do parallel rays of different colours deviate differently while passing through a glass prism?

Ans. This is because light rays of different colours travel with different speeds in glass.

Short Answer Type-I Questions

23. When one enters a dimly lit room from a place of intense light, he is not able to see anything

for some time. After some time, the things in the dimly lit room become visible. Explain how this happens.

Ans. This is because the size of the pupil becomes very small when the light is intense to control the amount of light entering the eye. The pupil takes some time to adjust to the dim conditions, so after some time, the things in the dimly lit room become visible.

24. Professor Gupta uses lenses of focal length +40 cm. Name the defect of vision he is suffering from. What is the power of the lens?

Ans. Since the focal length is positive, the lens is convex lens. Therefore, the defect Prof. Gupta is suffering from is hypermetropia.

$$\text{Power of the lens} = \frac{1}{f} \text{ (in m)} = \frac{1}{0.4} \text{ m} = + 2.5 \text{ D}$$

25. When a light ray passes obliquely through the atmosphere in an upward direction, how does its path generally change? What is the reason for this behaviour?

Ans. When a light ray passes through the atmosphere in an upward direction, it is passing from a denser medium into a rarer medium. Thus, it will deviate its path due to refraction and bend away from its path.

26. The minimum power of eye lens is 40 D. If the far point of normal eye is infinity, find the size of the eyeball.

Ans. Since minimum power of eye lens is +40 D,

$$\text{Maximum focal length, } f = \frac{1}{40} = 0.025 \text{ m} = 2.5 \text{ cm}$$

Far point of normal eye is infinity, i.e. $u = \infty$

Using lens formula,

$$\frac{1}{2.5} = \frac{1}{v} - \frac{1}{\infty}$$

or $v = f = 2.5 \text{ cm}$

This is the distance of the retina from the eye lens, which is the size of the eyeball.

Therefore, size of the eyeball is 2.5 cm.

Short Answer Type-II Questions

27. A person suffering from short-sightedness can see clearly only up to a distance of 2 m. Find the nature and power of lens required to correct his vision.

Ans. Since the person suffers from short-sightedness or myopia, the lens required to correct his vision is a concave lens.

The far point for the person is 2 m. He must use a lens of focal length that forms the virtual image

of a distant object at the far point of his defective eye.

This means $u = -\infty$ and $v = -2 \text{ m} = -200 \text{ cm}$

Using lens formula,

$$\frac{1}{f} = \frac{1}{(-200 \text{ cm})} - \frac{1}{(-\infty)}$$

or
$$\frac{1}{f} = \frac{-1}{200 \text{ cm}} = \frac{-1}{2 \text{ m}}$$

Power of the lens, $= \frac{1}{f} = \frac{-1}{2 \text{ m}} = -0.5 \text{ D}$

28. For a person, distance between the crystalline lens of eye and retina is 2.4 cm. What is the normal power of his lens system? What will be the power of his lens while reading a book placed at a distance of 25 cm from the eye?

Ans. Since the distance between the lens and the retina is 2.4 cm, $v = 2.4 \text{ cm}$

For a distant object, $u = -\infty$

Using lens formula,

$$\frac{1}{f} = \frac{1}{2.4} - \frac{1}{(-\infty)}$$

or $f = 2.4 \text{ cm} = 0.024 \text{ m}$

Therefore, power $= \frac{1}{f} = \frac{1}{0.024} = +41.7 \text{ D}$

For a book placed at 25 cm from the eye,

$$u = -25 \text{ cm}$$

Using lens formula,

$$\frac{1}{f} = \frac{1}{(2.4 \text{ cm})} - \frac{1}{(-25 \text{ cm})}$$

or $f = 2.19 \text{ cm} = 0.0219 \text{ m}$

Therefore, power $= \frac{1}{f} = \frac{1}{0.0219} = +45.7 \text{ D}$

29. The following figure shows an experimental set-up for observing a phenomenon of light in colloidal solutions. A student dissolves about 200 g of sodium thiosulphate (hypo) in about 2 L of clean water in the tank and adds about 1 mL to 2 mL of concentrated H_2SO_4 to the water.

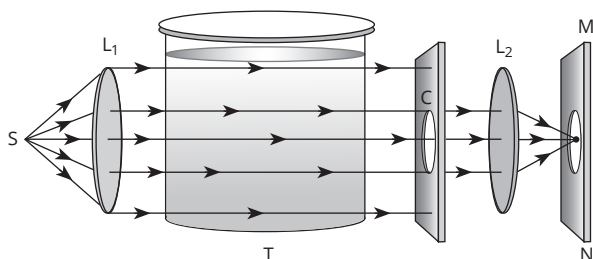

What would he observe after the source of light S is switched on:

- (a) from the three sides of the glass tank, and
(b) from the fourth side of the glass tank facing the circular hole?

Ans. (a) The student will observe blue light from the three sides of the glass tank because of scattering of light of smaller wavelengths by small sized particles present in the colloidal solution.

- (b) On the fourth side of the glass tank or on the screen, the student will first observe orange-red colour and then a bright crimson-red colour. This is because light of longer wavelengths is not scattered and reaches the screen from the other side of the tank.

Long Answer Type Questions

30. A person uses a lens of power -5 D for correcting his distant vision, and a lens of power $+1 \text{ D}$ to correct his near vision. What is the focal length of the lens required to correct his

- (a) distant vision (b) near vision?

Ans. For distant vision: Power $= -5 \text{ D}$

Focal length, $f = \frac{1}{(-5 \text{ D})} = -0.2 \text{ m} = -20 \text{ cm}$

Therefore, the focal length of the lens for correcting the person's distant vision is -20 cm .

For near vision: Power $= +1 \text{ D}$

Focal length, $f = \frac{1}{(+1 \text{ D})} = +1 \text{ m} = +100 \text{ cm}$

Therefore, the focal length of the lens for correcting the person's near vision is $+100 \text{ cm}$.

31. An object is placed at the least distance of distinct vision in front of eye. Draw ray diagrams showing position of image for

- (a) normal eye,
(b) myopic eye, and
(c) hypermetropic eye.

Ans. The following set of ray diagrams shows the image formation for the three conditions.

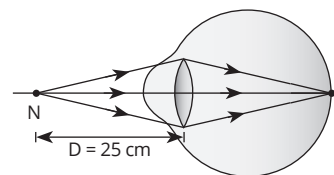

(a) Normal eye

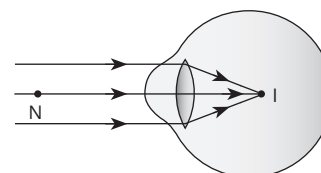

(b) Myopic eye

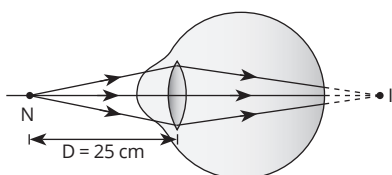

(c) Hypermetropic eye

32. A beam of white light falling on a glass prism gets split up into seven colours marked 1 to 7 as shown in the figure below.

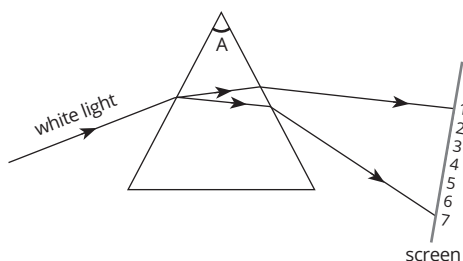

- (a) The colours at positions marked 3 and 5 are similar to the colour of the sky and the colour of gold metal, respectively. Is this statement made by a student correct or incorrect? Justify.
- (b) Which of the above shown positions corresponds approximately to the colour of (i) brinjal, (ii) danger signal, (iii) neel, which is applied to clothes, and (iv) orange?

- Ans.** (a) The student's statement is incorrect. Number 3 corresponds to yellow colour, which is the colour of gold. Number 5 corresponds to blue colour, which is the colour of the sky.
- (b) (i) Colour of brinjal is violet, which corresponds to position 7.
 (ii) Colour of danger signal is red, which corresponds to position 1.
 (iii) Colour of neel is indigo, which corresponds to position 6.
 (iv) Colour of orange is orange, which corresponds to position 2.

Let's Compete

(Page 63)

Multiple-Choice Questions

1. During refraction of a light ray through a glass prism, the following angles are measured:
 i = angle of incidence, e = angle of emergence, d = angle of deviation, and A = angle of prism
 Which of the following results is the correct one?
- (a) $i + e = A + d$ (b) $i + A = e + d$
 (c) $i + e = e + d$ (d) $i + d = A + e$

Ans. The correct answer is (a).

2. The layer of atmosphere near the earth's surface as compared to the layers at higher altitudes is optically
- (a) rarer.
 (b) denser.
 (c) both rarer and denser.
 (d) none of these.

Ans. The correct answer is (b).

3. A ray of light falls on one face of an equilateral glass prism at 40° and emerges from the other face at the same angle. The deviation suffered by the ray is
- (a) 60° (b) 40°
 (c) 80° (d) 20°

Ans. The angle of deviation is given by the formula, $\delta = i + e - A$, where i is the angle of incidence, e is the angle of emergence, and A is the refracting angle of the prism. Since this is an equilateral prism, $A = 60^\circ$.

Substituting in the formula, $\delta = 40^\circ + 40^\circ - 60^\circ = 20^\circ$. Therefore, the correct answer is (d).

4. What is the frequency of violet colour of wavelength 4000 \AA ?
- (a) $3.75 \times 10^{14} \text{ Hz}$ (b) $7.5 \times 10^{14} \text{ Hz}$
 (c) $7.5 \times 10^{15} \text{ Hz}$ (d) $9 \times 10^{15} \text{ Hz}$

Ans. Wavelength = 4000 \AA
 $= 4000 \times 10^{-10} \text{ m}$
 $= 4 \times 10^{-7} \text{ m}$

Frequency = $\frac{\text{Speed of light}}{\text{wavelength}}$
 $= \frac{3 \times 10^8 \text{ m/s}}{4 \times 10^{-7} \text{ m}}$
 $= 7.5 \times 10^{14} \text{ Hz}$

Therefore, the correct answer is (b).

5. The term 'power of accommodation' of eye means its ability to
- (a) change the distance from the lens to retina.
 (b) adjust the size of pupil so as to control the amount of light.
 (c) to adjust the focal length of eye lens.
 (d) to make the inverted image formed on retina as an erect image.

Ans. The correct answer is (c).

6. Due to atmospheric refraction, the time from sunrise to sunset at a place appears to increase by
- (a) 4 minutes. (b) 2 minutes.
 (c) $\frac{1}{2}$ minute. (d) none of these.

Ans. The correct answer is (a).

7. The yellow spot behind the pupil in the eye comprises
- rods and cones.
 - entirely of rods.
 - entirely of cones.
 - neither rods nor cones.

Ans. The correct answer is (c).

8. The rods in the eye are sensitive to
- intensity of light.
 - colour of light.
 - frequency of light.
 - all of these.

Ans. The correct answer is (a).

9. The far point of a person is 75 cm in front of the eye. What is the nature of lens required to correct the problem?
- Convex lens
 - Concave lens
 - Bifocal lens
 - There is no problem so no lens is required.

Ans. The person cannot see objects beyond 75 cm clearly. She suffers from myopia. Therefore, the correct answer is (b).

10. The wavelengths corresponding to violet, yellow and red lights are λ_v , λ_y and λ_r respectively. Arrange the wavelengths in the increasing order.
- $\lambda_v > \lambda_y > \lambda_r$
 - $\lambda_v < \lambda_y < \lambda_r$
 - $\lambda_y < \lambda_v < \lambda_r$
 - $\lambda_y < \lambda_r < \lambda_v$

Ans. The correct answer is (b).

Value-based Questions

(Optional) (Page 64)

1. A Physics teacher was explaining to her class that our eyes can live even after our death. She told them that by donating our eyes after we die, one pair of our eyes can give vision to two corneal blind people. Eye donors may belong to any sex or age group. Eye banks have been established for this purpose, where we can pledge to donate our eyes after our death.

- What function does the cornea serve in the eye?
- Can people who have been using spectacles or those who have been operated for cataract donate their eyes?

(c) Most people can donate their eyes. Why is such a pledge necessary?

Ans. (a) The cornea acts as the eye's outermost lens. It functions like a window that controls and focuses the entry of light into the eye.

(b) Yes, they can.

(c) We should all donate our eyes, unless advised against it by a doctor, because it does not cost anything to us or hurt us. But it can change the lives of two individuals. The pledge is necessary because the eyes are removed from our body after we die and then implanted in two corneal blind people. The pledge is signed in the presence of next of kin, who will be in charge of our body after we die.

2. Harry and Sejal are friends studying together in Class V. While Sejal can read a book keeping it at a normal distance of about 25 cm, Harry has to keep the book at about 50 cm from her eyes. Harry feels it is a natural defect of her eyes, which cannot be corrected. But, Sejal is smarter. She tells him that medical science is advanced and there must be treatment for this problem. The doctor, on checking, prescribes spectacles of suitable power to Harry and his vision becomes normal with these glasses.

- What defect was there in Harry's vision?
- What could be the causes of this defect?
- Calculate nature and power of the lens prescribed by the doctor. Assume that Harry can read the book from a distance of 25 cm, which he could do from a distance of 50 cm without glasses.
- What are the values displayed by Sejal?

Ans. (a) Harry can't see nearby things clearly, so he suffers from hypermetropia.

(b) Decrease in size of eyeball or increase in focal length of eye lens

(c) Harry would need convex lens to correct his vision. Using lens formula,

$$\frac{1}{f} = \frac{-1}{25} - \frac{1}{(-50)} = \frac{1}{50}$$

Or $f = 50 \text{ cm} = 0.5 \text{ m}$

$$\text{Power} = \frac{1}{f} = \frac{1}{0.5 \text{ m}} \text{ m} = + 2 \text{ D}$$

(d) Sejal displays concern for her friend and awareness of scientific concepts

3. On a foggy day, Sara and her family had to go out of town in their car. The visibility was very poor, and driving would have been very difficult. Sara

had some yellow cellophane paper with her in her crafts box. She suggested to her father that they should use this paper in the car's headlight before setting out.

- (a) Why do motorists use yellow light on a foggy day rather than normal white light?
- (b) What values are shown by Sara?

Ans. (a) Motorists use yellow (or orange) light on a foggy

day because much of normal white light will get scattered by water droplets in the atmosphere. The yellow light has longer wavelength, does not get scattered as much and is visible from a longer distance.

- (b) Concern for safety, presence of mind, initiative, practical application of concepts learnt in classroom

12

Electricity

Checkpoint _____ (Page 67)

1. Electric current is the flow of particles with
 - (a) a negative charge.
 - (b) a positive charge.
 - (c) both positive and negative charges flowing opposite to each other.
 - (d) either positive or negative charge depending on the material.

Ans. The correct answer is (a).

2. Which of the following is not a conductor of electricity?
 - (a) Tap water
 - (b) Salt water
 - (c) Petrol
 - (d) Lime juice

Ans. Hydrocarbons cannot conduct electricity because they do not have free electrons. Therefore, the correct answer is (c).

3. In an electric bulb, light is produced due to the glowing of
 - (a) the glass case of the bulb.
 - (b) the thin filament.
 - (c) the thick wires supporting the filament.
 - (d) gases inside the glass case of the bulb.

Ans. The correct answer is (b).

4. What component of an electrical circuit do the following symbols represent?

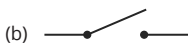

Ans. (a) cell, (b) switch off, (c) bulb

5. An electric heater used for cooking or an electric room heater contain a coil of wire that becomes red hot when the switch is turned on. What is this coil of wire called?

Ans. This coil of wire is called the element.

6. Classify the following materials into conductors and insulators of electricity:

iron, rubber, plastic, wood, glass, air, gold, copper

Ans. Conductors: iron, gold, copper; insulators: rubber, plastic, wood, glass, air

7. Which of these do you think uses less electrical energy – electric bulb or LED?

Ans. An LED uses less electrical energy than an electric bulb because part of the energy in a bulb gets wasted as heat.

8. What is the important role played by insulating materials in the building of electrical appliances?

Ans. Insulating materials provide protective covering for wires and appliances, which minimizes the risk of an electric shock when we handle these appliances.

9. If a ceiling fan uses up 3300 J of energy in a minute, what is its power?

Ans. Power = $\frac{\text{energy}}{\text{time}} = \frac{3300 \text{ J}}{60 \text{ s}} = 55 \text{ W}$

10. An electrical device has a rating of 300 W. What is the 30-day cost incurred in running it for 5 hours every day if the cost of electricity is ₹5 per unit?

Ans. Energy used up in running the device in one day

$$= 300 \text{ W} \times 5 \text{ h} \\ = 1500 \text{ Wh}$$

Energy used up in 30 days

$$= 1500 \text{ Wh} \times 30 \\ = 45000 \text{ Wh}$$

$$\begin{aligned}
 &= 45 \text{ kWh} \\
 &= 45 \text{ units} \\
 \text{Total cost incurred in 30 days} \\
 &= ₹5/\text{unit} \times 45 \text{ units} \\
 &= ₹225
 \end{aligned}$$

———— Milestone 1 ————

(Page 71)

Multiple-Choice Questions

1. A charge is taken from a point A to a point B. The work done per unit charge in the process is called
- the potential at A.
 - the potential at B.
 - the potential difference between B and A.
 - the current from A to B.

Ans. The correct answer is (c).

2. Joule/coulomb is the same as
- Watt.
 - Volt.
 - Ampere.
 - Ohm.

Ans. Potential difference = $\frac{\text{Work}}{\text{charge}}$.

The correct answer is (b).

3. Ampere-hour is a unit commonly used in electrical engineering. Which of these units is it equivalent to?
- Coulomb
 - Watt
 - Joule
 - Volt

Ans. The correct answer is (a).

4. An ammeter is always connected in and a voltmeter in The correct words that fill in the blanks are
- series, series.
 - series, parallel.
 - parallel, series.
 - parallel, parallel.

Ans. The correct answer is (b).

Very Short Answer Type Questions

5. Is it possible to have a particle with charge 2×10^{-19} C? Explain your answer.

Ans. No, charges can only in multiples of the charge of 1 electron (1.6×10^{-19} C).

6. The positive terminal of a cell is connected to the end A of a metallic wire AB and the negative terminal is connected to the end B. In which direction do electrons flow in the wire?

Ans. The electrons flow from B to A in the wire.

7. How much energy is given to each coulomb of charge passing through a 9 V battery?

Ans. Energy = $9 \text{ V} \times 1 \text{ C} = 9 \text{ J}$

8. A dry cell usually has a small cap at one end and a flat surface at the other end. Which of the two is at a higher potential and why?

Ans. The small cap end is at a higher potential. The small cap end in a dry cell is the cathode or the negative terminal, which has a higher potential.

Short Answer Type-I Questions

9. How much work will be done in bringing a charge of 5 millicoulombs from infinity to a point P at which the potential is 12 V?

Ans. Work done = $12 \text{ V} \times 5 \times 10^{-3} \text{ C}$
= 0.06 J

10. When a particle of charge $10 \mu\text{C}$ is brought from infinity to a point P, 2 mJ of work is done by the external forces. What is the potential at P?

Ans. Potential = $\frac{2 \times 10^{-3} \text{ J}}{10 \times 10^{-6} \text{ C}}$
= 200 V

11. A particle with a charge of 1.5 coulombs is taken from a point A at a potential of 50 V to another point B at a potential of 120 V. Calculate the work done.

Ans. Work done = $(120 \text{ V} - 50 \text{ V}) \times 1.5 \text{ C}$
= 105 J

12. How much charge flow through a wire in 10 minutes if the current through it is 2.5 A?

Ans. Charge = $2.5 \text{ A} \times 10 \times 60 \text{ s}$
= 1500 C

Short Answer Type-II Questions

13. In the given diagram, electric current is flowing from conductor A to conductor B when both conductors are connected by metallic wires. Label the diagram marking the following:

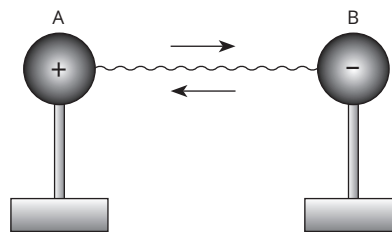

- conductor at higher potential
- conductor at lower potential
- direction of conventional current and
- direction of flow of electrons

Ans. (a) Conductor A is at a higher potential
(b) Conductor B is at a lower potential
(c) Conventional current flows from A to B

(d) Electrons flow from B to A

14. How many electrons should pass through a conductor in 1 second to constitute 1 ampere current?

Ans. Number of electrons = $\frac{1 \text{ A} \times 1 \text{ s}}{1.6 \times 10^{-19} \text{ C}}$
= 6.25×10^{18} electrons

15. Explain how an electric cell maintains a constant potential difference.

Ans. An electric cell maintains a constant potential difference between its terminals by virtue of chemical reactions going on inside the cell, i.e. by converting chemical energy into electrical energy.

Long Answer Type Question

16. What is meant by a circuit diagram? Draw a labelled diagram of an electric circuit comprising a cell, a resistor, an ammeter, a voltmeter and a switch.

Ans. A diagram that shows the arrangement of various electrical components used in an electric circuit with the help of their electrical symbols is called a circuit diagram.

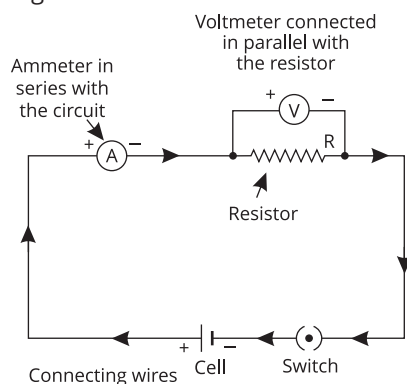

Milestone 2

(Page 78)

Multiple-Choice Questions

1. The slope of a V - I graph of a conductor gives
- resistance.
 - $\frac{1}{\text{resistance}}$.
 - resistivity.
 - product of potential difference and current.

Ans. The slope of a V - I graph is calculated by V/I , which is equal to R . Therefore, the correct answer is (a).

2. If the length of a conductor is increased three times without changing the cross sectional area, its resistance
- gets tripled.

- changes to one-third of the original value.
- remains the same.
- none of these.

Ans. We know that $R = \frac{\rho l}{A}$

Therefore, $R \propto l$

This means that if the resistivity and cross-sectional area are not changing, R increases in proportion to the increase in length

Thus, the correct answer is (a).

3. The current in a wire depends
- only on the potential difference applied.
 - only on the resistance of the wire.
 - on both of them.
 - on neither of them.

Ans. The correct answer is (c).

4. Three resistors of equal resistance are connected in series with a cell. If the current in each resistor is 2 A, the current in the cell will be
- 1 A.
 - 2 A.
 - 6 A.
 - 12 A.

Ans. If the three resistors are connected in series, the same amount of current passes through the three. This is the same current that passes through the cell also. Therefore, the correct answer is (b).

5. A substance that has very low resistivity is
- a good conductor.
 - a resistor.
 - an insulator.
 - none of these.

Ans. Low resistivity means that the resistance is low, which means that the substance conducts current well. Therefore, the correct answer is (a).

6. The best conductor among metals is
- copper.
 - aluminium.
 - tungsten.
 - silver.

Ans. The correct answer is (d).

7. If the total resistance of the circuit is less than the smallest resistance in the circuit, the resistors are connected in
- series.
 - parallel.
 - both series and parallel.
 - none of these.

Ans. Circuit resistance increases if resistors are in series and decreases if they are in parallel. For the circuit resistance to be less even than the smallest resistance, all resistors will have to be in parallel. The correct answer is (b).

Very Short Answer Type Questions

8. Consider the units volt, ohm and ampere. One of them is the same as the product of the other two. Which one is this?

Ans. Since V (volt) = I (ampere) \times R (ohm), the answer is volt.

9. You have two resistors of resistances 30Ω and 60Ω . What resistance can you get by combining the two in series?

Ans. Net resistance in series = $30 \Omega + 60 \Omega = 90 \Omega$

10. Two resistors of 5Ω and 10Ω are connected in series in a circuit. What is the ratio of the current flowing through the first resistor to that flowing through the second?

Ans. When the resistors are in series, the same current passes through the two. Therefore, the ratio is 1 : 1.

11. What happens to current if the potential difference across the ends of a conductor is tripled?

Ans. $I = \frac{V}{R}$

If resistance remains unchanged, $I \propto V$

Therefore, if potential difference is tripled, the current gets tripled also.

12. For two wires made of the same material where one is thicker than the other, which wire offers a higher resistance per metre?

Ans. $R = \frac{\rho l}{A}$

If resistivity and length remain unchanged, $R \propto \frac{1}{A}$

The greater the cross-sectional area, the lower is the resistance.

Therefore, the thinner wire offers higher resistance per metre.

Short Answer Type-I Questions

13. A wire of resistance 10Ω is bent to form a closed circle. What is the resistance across the diameter of the circle?

Ans. Each half of the circle can be considered as a resistor of 5Ω . If we have to find the resistance across the diameter, these two resistors are connected in parallel. If net resistance is R ,

$$\frac{1}{R} = \frac{1}{5} + \frac{1}{5}$$

or $R = 2.5 \Omega$

14. Draw a circuit diagram for a circuit in which two resistors A and B are joined in series with a battery, and a voltmeter is connected to measure the potential difference across the resistor A.

Ans. The circuit diagram is shown below:

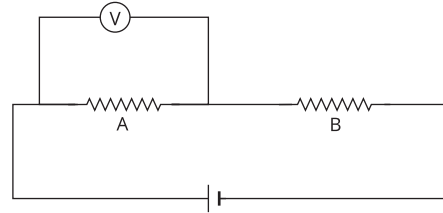

15. When a 9 V battery is connected across an unknown resistor, there is a current of 3 mA in the circuit. Find the value of the resistance of the resistor.

Ans. $V = I \times R$

$$\begin{aligned} \text{or } R &= \frac{V}{I} \\ &= \frac{9 \text{ V}}{3 \times 10^{-3} \text{ A}} \\ &= 3000 \Omega \end{aligned}$$

16. A piece of wire is redrawn by pulling it until its length is doubled and area is halved. Compare the new resistance with the original value.

Ans. Let the original length, area and resistance be l , A and R .

$$R = \frac{\rho l}{A}$$

If the new resistance is R' , we have

$$\begin{aligned} R' &= \frac{\rho \times 2l}{\left(\frac{A}{2}\right)} \\ &= \frac{4\rho l}{A} \\ &= 4R \end{aligned}$$

The new resistance is four times the original resistance.

17. What will be the length of a silver wire of resistance 6Ω if an 80 cm wire of the same material has a resistance of 3Ω ?

Ans. Since $R \propto l$

$$\frac{R_2}{R_1} = \frac{l_2}{l_1}$$

$$\text{or } \frac{6 \Omega}{3 \Omega} = \frac{l_2}{80 \text{ cm}}$$

$$\text{or } l_2 = 160 \text{ cm}$$

18. A uniform wire of resistance R is cut into three equal pieces, and these pieces are joined in parallel. What is the resistance of the combination?

Ans. When the wire is cut into three equal pieces, the resistance of each shorter wire becomes $\frac{R}{3}$.

[Since R is directly proportional to length]

If the net resistance on being combined in parallel is R' , we have

$$\frac{1}{R'} = \frac{1}{\left(\frac{R}{3}\right)} + \frac{1}{\left(\frac{R}{3}\right)} + \frac{1}{\left(\frac{R}{3}\right)}$$

or $R' = \frac{R}{9}$

Short Answer Type-II Questions

19. How many bulbs of resistance 6Ω should be joined in parallel to draw a current of 2 A from a battery of 3 V ?

Ans. The resistance needed, $R = \frac{3 \text{ V}}{2 \text{ A}} = 1.5 \Omega$

We have, $\frac{1}{R} = \frac{1}{6} + \frac{1}{6} + \dots n \text{ times}$ so that

$$R = 1.5 \Omega$$

or $\frac{1}{1.5} = \frac{n}{6}$

or $n = \frac{6}{1.5} = 4$

Therefore, four bulbs should be joined in parallel.

20. Three resistors are connected in parallel such that their total resistance is 3Ω . If the resistances of two of the resistors are 10Ω and 30Ω , find the resistance of the third resistor.

Ans. $\frac{1}{3} = \frac{1}{10} + \frac{1}{30} + \frac{1}{R}$

or $\frac{1}{R} = \frac{1}{3} - \frac{1}{10} - \frac{1}{30}$

or $R = 5 \Omega$

21. Find the total resistance of each of the following two circuits:

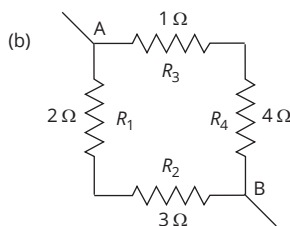
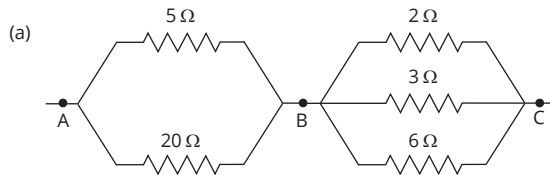

Ans. (a) $\frac{1}{R_{AB}} = \frac{1}{5} + \frac{1}{20}$

or $R_{AB} = 4 \Omega$

$$\frac{1}{R_{BC}} = \frac{1}{2} + \frac{1}{3} + \frac{1}{6}$$

or $R_{BC} = 1 \Omega$

$$R_{AC} = R_{AB} + R_{BC} = 4 \Omega + 1 \Omega = 5 \Omega$$

(b) R_1 and R_2 are in series, while R_3 and R_4 are in series

$$R_{12} = 2 \Omega + 3 \Omega = 5 \Omega$$

$$R_{34} = 1 \Omega + 4 \Omega = 5 \Omega$$

$$\frac{1}{R_{AB}} = \frac{1}{R_{12}} + \frac{1}{R_{34}}$$

or $\frac{1}{R_{AB}} = \frac{1}{5} + \frac{1}{5}$

or $R_{AB} = 2.5 \Omega$

22. When two resistors are joined in series, the equivalent resistance is 90Ω . When the same resistors are joined in parallel, the equivalent resistance is 20Ω . Calculate the resistance of the two resistors.

Ans. Let the resistance of the first resistor be $x \Omega$ and that of the second be $y \Omega$

$$x + y = 90 \Omega$$

or $x = 90 - y$

$$\frac{1}{x} + \frac{1}{y} = \frac{1}{20}$$

or $\frac{1}{(90-y)} + \frac{1}{y} = \frac{1}{20}$

or $y = 60 \Omega$ or $y = 30 \Omega$

If $y = 60 \Omega$, $x = 30 \Omega$

If $y = 30 \Omega$, $x = 60 \Omega$

Long Answer Type Question

23. In the circuit diagram given below, calculate

- the current through each resistor
- the total current in the circuit
- the total circuit resistance, when a 16 V battery is connected.

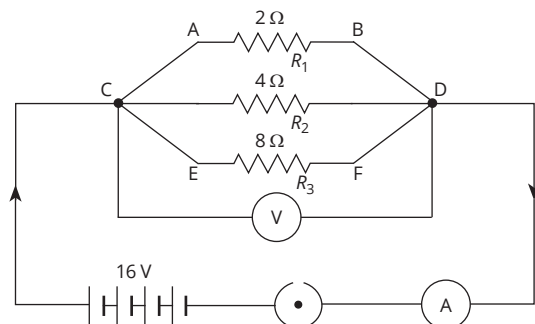

Ans. (c) If the total circuit resistance is R , we have

$$\frac{1}{R} = \frac{1}{R_1} + \frac{1}{R_2} + \frac{1}{R_3}$$

or
$$\frac{1}{R} = \frac{1}{2} + \frac{1}{4} + \frac{1}{8}$$

or
$$R = \frac{8}{7} \Omega$$

$$= 1.14 \Omega$$

(b) The total current in the circuit,

$$I = \frac{V}{R}$$

$$= \frac{16 \text{ V}}{\left(\frac{8}{7} \Omega\right)} = 14 \text{ A}$$

(a) The current flows through each resistor in inverse proportion to the resistance.

$$\text{Current through } R_1 = \frac{14 \text{ A}}{\left(\frac{2 \times 7}{8}\right)} = 8 \text{ A}$$

$$\text{Current through } R_2 = \frac{14 \text{ A}}{\left(\frac{4 \times 7}{8}\right)} = 4 \text{ A}$$

$$\text{Current through } R_3 = \frac{14 \text{ A}}{\left(\frac{8 \times 7}{8}\right)} = 2 \text{ A}$$

Milestone 3

(Page 82)

Multiple-Choice Questions

1. Which one of these gases are you likely to find inside an electric bulb?

- (a) Oxygen (b) Hydrogen
 (c) Neon (d) Ozone

Ans. The correct answer is (c).

2. Electric power in terms of V and R is

- (a) $\frac{V^2}{R}$ (b) $\frac{V}{R^2}$
 (c) $\frac{R^2}{V}$ (d) $\frac{R}{V^2}$

Ans. Electric power = $V \times I = V \times \frac{V}{R} = \frac{V^2}{R}$. The correct answer is (a).

3. For an electrical appliance, the values of and taken together form the rating of the appliance. Fill the blanks with the right pair of words.

- (a) current, voltage (b) power, resistance
 (c) resistance, voltage (d) power, voltage

Ans. The correct answer is (d).

4. For an electric iron that consumes 1 kW electric power when operated at 220 V, a fuse of what rating should be used?

- (a) 2 A (b) 3 A
 (c) 4 A (d) 5 A

Ans. Power, $P = V \times I$

or
$$I = \frac{P}{V}$$

$$= \frac{1000 \text{ W}}{220 \text{ V}} = 4.5 \text{ A}$$

The only option higher than this is 5 A, so the correct answer is (d).

Very Short Answer Type Questions

5. What is the cause of the heating effect of current?

Ans. As current flows, the free electrons lose energy, which is converted into heat.

6. Between a 100 W bulb and a 60 W bulb, which converts more electrical energy into heat and light?

Ans. The 100 W bulb converts more electrical energy into heat and light.

7. Inside a cell, negative charges flow from the positive to the negative terminal. What is the work done by the cell in terms of Q and V ?

Ans. Work done = Power \times time
 $= V \times I \times t$
 $= V \times \frac{Q}{t} \times t$
 $= V \times Q$

Short Answer Type-I Questions

8. Which uses more energy, a 100 W bulb in 10 hours or a 1500 W AC in 1 hour?

Ans. Energy used by the bulb
 $= 100 \text{ W} \times 10 \times 3600 \text{ s}$
 $= 3600000 \text{ J}$

Energy used by the AC
 $= 1500 \text{ W} \times 3600 \text{ s}$
 $= 5400000 \text{ J}$

The AC uses more energy.

9. Why is nichrome wire generally used as heating element in heating appliances? Give any three reasons.

Ans. Nichrome wire is generally used as a heating element because:

- (i) It has a very high resistance.
 (ii) It has a high melting point.
 (iii) It has low thermal expansion.

10. An electric heater of 1000 W draws a current of 4 A. Calculate the voltage of the supply line.

Ans. Voltage = $\frac{\text{Power}}{I}$
 $= \frac{1000 \text{ W}}{4 \text{ A}}$
 $= 250 \text{ V}$

11. A current of 10 A flows through an electric oven of resistance 80 Ω in 1 hour. Calculate the rate of generation of heat.

Ans. Rate of generation of heat
 $= \text{Power}$
 $= I^2 R$
 $= (10 \text{ A})^2 \times 80 \Omega$
 $= 8000 \text{ J/s}$

Short Answer Type-II Questions

12. Prove that the heat produced in a conductor of resistance R on passing current I through it for time t is $H = I^2 R t$.

Ans. When Q moves against V , amount of work done,

$$W = Q \times V$$

We know that $Q = I \times t$

Also, $V = I \times R$

Therefore, $W = (I \times t) \times (I \times R) = I^2 R t$

Electrical work done is the same as heat generated, so

$$H = I^2 R t$$

13. A current is passed through a resistor for some time. It produces 400 calories of heat in this period. If the current is doubled, how much heat will be produced for the same duration?

Ans. We know that $H \propto I^2$

So if I increases by 2 times, H increases by 4 times

Therefore, heat generated will be $4 \times 400 \text{ cal} = 1600 \text{ cal}$

14. One electric geyser rated 1500 W, 220 V and an electric iron rated 400 W, 220 V are connected in parallel. Calculate the current drawn from the main line.

Ans. Since the two devices are in parallel, the total current drawn from the main line is the sum of the current drawn by each device

$$\text{Current in the geyser, } I_1 = \frac{P}{V} = \frac{1500 \text{ W}}{220 \text{ V}}$$

$$\text{Current in the iron, } I_2 = \frac{P}{V} = \frac{400 \text{ W}}{220 \text{ V}}$$

$$\text{Total current drawn} = I_1 + I_2 = \frac{1500 + 400}{220}$$

$$= 8.64 \text{ A}$$

15. An electric circuit working at 220 V can supply a maximum current of 20 A. How many electric bulbs of power 10 W can be lighted by this circuit in parallel?

Ans. Current needed by each bulb,

$$I = \frac{10 \text{ W}}{220 \text{ V}} = 0.045 \text{ A}$$

$$\text{Number of bulbs} = \frac{20 \text{ A}}{0.045 \text{ A}} = 444 \text{ bulbs}$$

16. An electric oven of resistance 20 Ω draws a current of 10 A. It works 3 hours daily. Calculate the monthly bill when energy costs ₹ 4 per kWh.

Ans. Power = $I^2 R$
 $= (10 \text{ A})^2 \times 20 \Omega$
 $= 2000 \text{ W}$

Energy consumed daily
 $= 2000 \text{ W} \times 3 \text{ h}$
 $= 6000 \text{ Wh}$
 $= 6 \text{ kWh}$

Energy consumed in a month
 $= 30 \text{ days} \times 6 \text{ kWh}$
 $= 180 \text{ kWh}$
 Monthly bill = ₹ 4/kWh \times 180 kWh
 $= ₹ 720$

Long Answer Type Questions

17. A heater draws 1100 W at 220 V.

- (a) Find the resistance of the heater when in ON condition.
 (b) Calculate the kilowatt hours consumed in a week if the heater is used daily for four hours at the rated voltage.

Ans. (a) Power = $\frac{V^2}{R}$
 or $R = \frac{V^2}{\text{Power}}$
 $= \frac{(220 \text{ V})^2}{1100 \text{ W}}$
 $= 44 \Omega$

(b) Daily energy consumed
 $= 1100 \text{ W} \times 4 \text{ h}$
 $= 4400 \text{ Wh}$
 $= 4.4 \text{ kWh}$

Weekly consumption = $7 \times 4.4 \text{ kWh} = 30.8 \text{ kWh}$

18. A bulb used in a car is rated at 12 V, 48 W. Find the energy consumed in one minute when the bulb is connected to

- (a) a 12 V battery, and
 (b) a 6 V battery.

Ans. Resistance of the bulb = $\frac{(12\text{ V})^2}{48\text{ W}} = 3\ \Omega$

(a) Energy consumed = $\frac{(12\text{ V})^2}{3\ \Omega} \times 60\text{ s} = 2880\text{ J}$

(b) Energy consumed = $\frac{(6\text{ V})^2}{3\ \Omega} \times 60\text{ s} = 720\text{ J}$

19. In a house, five 100 W electric bulbs are lit for 6 hours, and a 1500 W electric heater is used for 2 hours daily.

(a) Calculate the electrical energy consumed in 30 days.

(b) Calculate the cost if the rate is ₹ 4 per unit.

Ans. (a) Daily consumption = $5 \times 100\text{ W} \times 6\text{ h} + 1500\text{ W} \times 2\text{ h} = 6000\text{ Wh} = 6\text{ kWh}$

Consumption in 30 days = $6\text{ kWh} \times 30 = 180\text{ kWh}$

(b) Cost = $\text{₹}4/\text{kWh} \times 180\text{ kWh} = \text{₹}720$

Higher Order Thinking Skills (HOTS) Questions

(Page 83)

1. If a wire of resistivity (ρ) is stretched to thrice its initial length, what will be its new resistivity?

Ans. The resistivity will remain the same because it does not depend on the dimensions of the wire but on the material of the wire.

2. In the circuit diagram shown below, the two resistance wires A and B are of the same length and the same material. But A is thicker than B. Which ammeter, A_1 or A_2 , will indicate higher reading for current? Give reason.

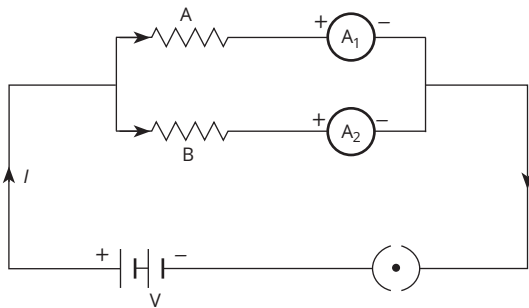

Ans. $R \propto \frac{1}{A}$, which means that the thicker the wire is,

the lower is its resistance. If between two resistors of the same length and material, one wire is thicker than the other, the thicker wire will have lower resistance of the two. Since it has lower resistance, it will allow more current to pass

through. Therefore, in the given question, A_1 will show a higher reading for current.

3. Three V - I graphs are drawn individually for two resistors R_1 and R_2 and their parallel combination. Out of graphs A, B and C, which two represent the individual resistors and which one represents their parallel combination? Give reason.

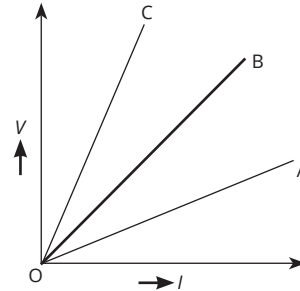

Ans. When two resistors are connected in parallel, the resistance of the combination is always less than the resistance of the individual resistors. The slope of the V - I graph signifies resistance, i.e. the higher the slope of the graph, the higher is the resistance. Out of A, B, and C, the lowest slope is of A. Therefore, A represents the parallel combination.

4. Two identical wires, one of nichrome and the other of copper, are connected in series and a current I is passed through them. What is the change observed in the temperature of the two wires? Justify your answer.

Ans. Since the two wires are in series, the same amount of current passes through them. Now, since the resistivity of nichrome is much higher than that of copper, if the wires are identical in length and area, the resistance of the nichrome wire will be much higher than that of the copper wire. If the resistance is higher, the heat generated is also higher ($H = I^2Rt$), so the nichrome will heat up much faster than the copper wire does.

5. A fuse wire melts at 5 A. If it is desired that the fuse wire melts at 10 A, then should the new fuse wire be of a smaller or a larger radius than the earlier one? Give reasons for your answer.

Ans. For the fuse wire to melt at a higher value of current flow, according to the Joule's law of heating, the resistance will have to be reduced. Since resistance is inversely proportional to cross-sectional area, to decrease the resistance, the area will have to be increased. Therefore, a wire of a larger radius will have to be used to make the new fuse wire.

6. The electric power consumed by a device may be expressed either as $P = I^2R$ or as $P = V^2/R$. The first expression suggests that power is directly proportional to resistance R , but the second expression suggests that power is inversely proportional to R . How do you reconcile these two contradictory relations?

Ans. There is no contradiction in the two expressions. The relation $P = I^2R$ is used when the same current flows through different resistors. For example, in a series combination of resistors, the power consumed in a nichrome wire is more than that in a copper wire of same dimensions. The relation $P = \frac{V^2}{R}$ is used when the same potential difference is applied across all resistors. For example, the resistance of a 100 W, 220 V rating bulb is less than that of a bulb of 40 W, 220 V rating.

7. Can high voltage in your body be produced without you getting a shock?

Ans. Yes, if the entire body is at the same potential, it does not experience a shock. For instance, if we can hang from a high voltage line without touching the ground (like birds sitting on wires), we will not experience a shock.

8. Why is much less heat generated in long electric cables than in filaments of electric bulbs?

Ans. As the long cable wires have more cross sectional area, the resistance produced is little as compared to a filament wire. The long cables are made up of a good conductor of electricity and hence the resistance is also little as compared to a filament.

- (c) current. (d) none of these.

Ans. The correct answer is (c).

4. In order to distribute a high potential, we connect a number of resistors

- (a) in series.
(b) in parallel.
(c) partially in series and partially in parallel.
(d) none of these.

Ans. $V = I \times R$, so higher the net resistance, higher is the potential. Therefore, the answer is (a).

5. For the three circuits shown in the figure below, the same two resistors R_1 and R_2 have been connected in parallel in all the circuits, but the ammeter and the voltmeter have been connected in three different positions.

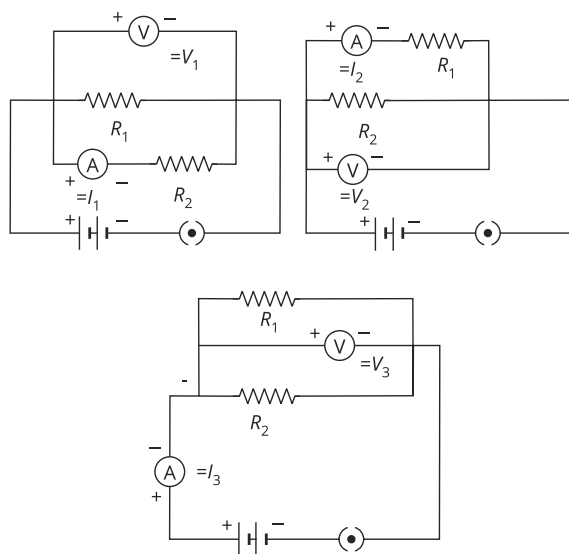

The relation between the three voltmeter and ammeter readings would be:

- (a) $V_1 = V_2 = V_3$ and $I_1 = I_2 = I_3$
(b) $V_1 \neq V_2 \neq V_3$ and $I_1 = I_2 = I_3$
(c) $V_1 = V_2 = V_3$ and $I_1 \neq I_2 \neq I_3$
(d) $V_1 \neq V_2 \neq V_3$ and $I_1 \neq I_2 \neq I_3$

Ans. The voltage in each case is across the two resistors in parallel. So $V_1 = V_2 = V_3$. The current, however, is different in arms in each case. Therefore, $I_1 \neq I_2 \neq I_3$. The correct answer is (c).

Assertion-Reason Type Questions

For question numbers 6 to 15, two statements are given – one labelled Assertion (A) and the other labelled Reason (R). Select the correct answer to these questions from the codes (a), (b), (c) and (d) as given below.

- (a) Both A and R are true and R is the correct explanation of the assertion.

Self-Assessment

(Page 83)

Multiple-Choice Questions

1. In a metal,
(a) all the electrons are free to move.
(b) all the electrons are bound to their parent atoms.
(c) there are no electrons.
(d) some electrons are free to move.

Ans. The correct answer is (d).

2. An electric current is constituted by the flow of
(a) neutrons. (b) electrons.
(c) protons. (d) any one of these.

Ans. The correct answer is (b).

3. In an electric circuit, rheostat is used to change the
(a) potential difference. (b) potential.

- (b) Both A and R are true but R is not the correct explanation of the assertion.
- (c) A is true but R is false.
- (d) A is false but R is true.

6. Assertion: 1 volt can also be written as 1 joule/coulomb.

Reason: 1 volt is the potential difference between two points when 1 J of work is done to move 1 C of electric charge from one point to the other.

Ans. (a)

7. Assertion: Current moves from higher potential to lower potential.

Reason: A free negative charge moves from higher potential to lower potential.

Ans. (c)

8. Assertion: Tungsten is used in light bulbs and not copper.

Reason: If the thickness of the tungsten filament in a light bulb is increased, its resistance will decrease.

Ans. (b)

9. Assertion: When an electrical wire is bent, its resistance increases.

Reason: Resistance of an electrical wire depends on the resistivity, length and cross-sectional area of the wire.

Ans. (d)

10. Assertion: Even though the same amount of current flows through a line wire and a bulb, the heat produced in the bulb's filament is much higher than that in the wire.

Reason: The filament of bulb is made of a material with high resistivity and high melting point.

Ans. (a)

11. Assertion: The resistance of a conductor increases with increase in temperature.

Reason: The free electrons in a conductor are able to move more freely when the temperature is increased.

Ans. (c)

12. Assertion: A 200 W bulb glows with more brightness than a 100 W bulb does for the same supply voltage.

Reason: The 100 W bulb has higher resistance than a 200 W bulb does.

Ans. (a)

13. Assertion: When resistors are connected in parallel, the net resistance of the combination always decreases.

Reason: The sum of the amount of current flowing through each resistor connected in parallel is equal to the total current flowing from the source.

Ans. (b)

14. Assertion: If an electrical wire is cut to half its former length, its resistivity is also halved.

Reason: Resistivity is a property of a material and constant at a given temperature.

Ans. (d)

15. Assertion: Home appliances are connected in parallel.

Reason: The same amount of current needs to flow through every home appliance.

Ans. (c)

Source-based/Case-based/Passage-based/Integrated Questions

Answer the questions on the basis of your understanding of the following paragraphs and the related studied concepts.

- 16.** In the US, Canada, and most South American countries, the electricity supply is at 120 V, 60 Hz, while in other countries, including Europe, India and China, the supply is at 220 V, 50 Hz. While many modern appliances are now available at dual voltage, which makes it possible to use them in any country, there are others (hair dryers, electric kettles, heaters, etc.) that are generally meant to be used for only one of these voltages. This means that travellers cannot use certain appliances purchased in the USA in India, and vice versa. Thankfully, there are voltage converters available in the market, which can raise or lower the voltage in a circuit and can be used with certain appliances even if they are not dual voltage.



- 1.** (a) What will happen if an appliance meant to be used in the USA is connected to the power supply in India and switched on?
 (b) What will happen if an appliance from India is connected to the power supply in the USA and switched on?

- (c) A voltage converter is a smaller, portable version of which machine used in the transmission of electricity?
- (d) Why is electricity supply at 220 V considered cheaper for electricity transmission than the supply at 120 V?

Ans. (a) The power drawn would be nearly four times the power needed for the appliance, burning the fuse and damaging the appliance.

(b) The power drawn will be nearly one-fourth of the power needed for the appliance, so it will remain switched on but won't work and could damage the motor.

(c) A transformer

(d) Doubling the voltage cuts the current needs in half, which means lighter and less expensive wires are needed for transmission of electricity.

II. (a) What is the voltage and frequency of the domestic electricity supply in the United States of America?

- (i) 220 V, 50 Hz (ii) 230 V, 60 Hz
(iii) 120 V, 60 Hz (iv) 120 V, 50 Hz

Ans. (iii) 120 V, 60 Hz

(b) What is the voltage and frequency of the domestic electricity supply in India?

- (i) 220 V, 50 Hz (ii) 230 V, 60 Hz
(iii) 120 V, 60 Hz (iv) 120 V, 50 Hz

Ans. (i) 220 V, 50 Hz

(c) Which component is used to vary the current in the circuit by changing the resistance?

- (i) Ammeter (ii) Voltmeter
(iii) Rheostat (iv) Galvanometer

Ans. (iii) Rheostat

(d) One volt is equal to

- (i) 1 ampere/1 ohm.
(ii) 1 joule/1 coulomb.
(iii) 1 coulomb/1 joule.
(iv) 1 ohm/1 ampere.

Ans. (ii) 1 joule/1 coulomb.

(e) If the potential difference between the ends of a fixed resistor is halved, the electric power will become

- (i) half. (ii) one-fourth.
(iii) double. (iv) eight times.

Ans. (ii) one-fourth.

17. American Wire Gauge (AWG) is a standardised wire gauge system used since 1857 for the diameters of round, solid, non-ferrous, electrically conducting wires. In this system, increasing gauge numbers denote decreasing wire diameters, with AWG 1 corresponding to a diameter of 7.348 mm. The diameters for increasing gauge numbers decrease

geometrically, such that the diameter for AWG 2 is about 1.123 times less than the diameter for AWG 1 (6.544 mm), diameter for AWG 3 is 1.123 times less than that for AWG 2, and so on. The purpose of the gauge system is that it makes it easy to standardise wire diameters across different manufacturers and also makes it easier to remember for a user what sized wire to use for different circuits. Generally, the material referred to in AWG is copper (resistivity at 25 °C = 1.72×10^{-8} ohm m; temperature coefficient = 0.393%).



I. (a) What American wire gauge number corresponds to a diameter of 4.621 mm?

(b) What is the resistance (in mΩ/m) for a copper wire of AWG 1 at 25 °C?

(c) Will the resistance/meter of a copper wire increase with increase in gauge number or decrease?

(d) What is the resistance (in mΩ/m) for a copper wire of AWG 1 at 30 °C?

Ans. (a) 5

(b) 0.4066 mΩ/m

(c) Increase

(d) 0.4146 mΩ/m

II. (a) What does AWG stand for?

- (i) Automatic Wire Gauge
(ii) Aluminium Wire Gauge
(iii) American Wire Gauge
(iv) Australian Wire Gauge

Ans. (iii) American Wire Gauge

(b) What American Wire Gauge number corresponds to a diameter of 4.115 mm?

- (i) 4 (ii) 5
(iii) 6 (iv) 7

Ans. (iii) 6

(c) What is the SI unit of resistivity?

- (i) newton-metre (ii) ohm-metre
(iii) ohm (iv) watt

Ans. (ii) ohm-metre

(d) The resistivity of a substance does not depend on its

- (i) length or thickness.

- (ii) nature of the material.
- (iii) temperature of the material.
- (iv) none of the above.

Ans. (i) length or thickness.

(e) The elements of electrical heating devices are usually made up of

- (i) copper. (ii) bronze.
- (iii) aluminium. (iv) nichrome.

Ans. (iv) nichrome.

Very Short Answer Type Questions

18. A toaster produces more heat than a light bulb when connected in parallel to the 220 V mains. Which of the two has greater resistance?

Ans. Using $P = \frac{V^2}{R}$, the appliance that has less heat when connected in parallel across the same voltage has greater resistance. Therefore, the bulb has greater resistance in this case.

19. Two wires, one of magnesium and the other of copper, have equal lengths and resistances. Which one of the two wires will be thicker?

Ans. $R = \frac{\rho l}{A}$. If R and length remain the same, $\rho \propto A$.

Therefore, the wire with the higher resistivity has greater area. Since magnesium has higher resistivity than copper, the magnesium wire will be thicker.

20. What is the resistance of an air gap?

Ans. The resistance of air gap is almost infinity as no current passes through it.

21. Why is resistance higher in a series combination of resistors than in a parallel combination?

Ans. The resistance is higher in a series combination than in a parallel combination because in the former the effective length increases and resistance is directly proportional to length.

22. Give an example of a substance whose resistance decreases with temperature and another whose resistance remains unchanged with increase in temperature.

Ans. In Germanium, a semiconductor, the resistance decreases with temperature. In Manganin, an alloy of copper, nickel, and manganese, the resistance remains unchanged with increase in temperature.

Short Answer Type-I Questions

23. What is the ratio of equivalent resistance of a series combination of n equal resistances to the equivalent resistance of a parallel combination of these n resistances?

Ans. If n equal resistances of resistance, say R , are in

series, the equivalent resistance is given by,

$$R_s = R + R + R + \dots \text{ } n \text{ times}$$

or $R_s = nR$

If n equal resistances of R resistance are in parallel, the equivalent resistance is given by,

$$\frac{1}{R_p} = \frac{1}{R} + \frac{1}{R} + \frac{1}{R} + \dots \text{ } n \text{ times}$$

or $\frac{1}{R_p} = \frac{n}{R}$

or $R_p = \frac{R}{n}$

$$\frac{R_s}{R_p} = \frac{nR}{R/n} = n^2$$

24. The resistivities of copper and silver are $1.68 \times 10^{-6} \Omega \text{ cm}$ and $1.59 \times 10^{-6} \Omega \text{ cm}$, respectively. Which of the two is a better electrical conductor and why?

Ans. If we have two wires of identical dimensions made of two different materials, the wire made of the material with higher resistivity will have higher resistance. This is because $R \propto \rho$.

In the given case, since copper has higher resistivity, it has higher resistance. The higher the resistance is, the lower is its conducting ability. Therefore, silver is a better electrical conductor.

25. State the conditions under which Ohm's law is not obeyed in a conductor.

Ans. Ohm's law is not obeyed in a conductor under the following conditions:

- (i) The conductor is not an ohmic conductor, which is usually a wire of pure metal or alloy.
- (ii) The temperature and other physical conditions do not remain constant.

26. A current of 5 A flows through an electric press of resistance 44Ω . Calculate the energy consumed by the press in 5 minutes.

Ans. Energy = $I^2 R t$
 $= (5 \text{ A})^2 \times 44 \Omega \times 5 \times 60 \text{ s}$
 $= 330 \text{ kJ}$

27. Calculate the resistance of the wire using the I - V graph plotted for it.

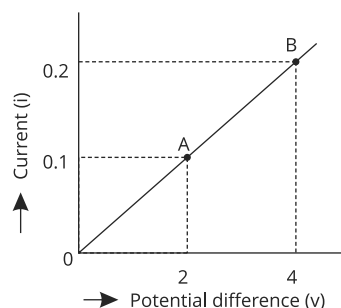

Ans. The resistance of the wire is the reciprocal of the slope of the I - V graph (since $\frac{1}{V} = \frac{1}{R}$).

$$\begin{aligned} \text{Slope} &= \frac{(0.2-0.1)}{(4-2)} \\ &= \frac{0.1}{2} = 0.05 \end{aligned}$$

$$\text{Therefore, resistance} = \frac{1}{0.05} = 20 \Omega$$

Short Answer Type-II Questions

28. An electric heater is used everyday for 120 minutes. The electricity bill for 30 days shows usage of 60 units. Calculate the power of the electric heater.

Ans. Usage in 30 days = 60 kWh

$$\text{Usage in 1 day} = \frac{60}{30} = 2 \text{ kWh}$$

The heater is used for 2 hours in a day

$$\text{Therefore, Power} = \frac{2 \text{ kWh}}{2 \text{ h}} = 1 \text{ kW} = 1000 \text{ W}$$

29. When two resistors of resistances R_1 and R_2 are connected in parallel, the net resistance is 3Ω . When connected in series, the resistance is 16Ω . Calculate the values of R_1 and R_2 .

Ans. $R_1 + R_2 = 16$

$$\text{or } R_1 = 16 - R_2$$

$$\frac{1}{R_1} + \frac{1}{R_2} = \frac{1}{3}$$

$$\text{or } \frac{1}{(16-R_2)} + \frac{1}{R_2} = \frac{1}{3}$$

$$\text{or } R_2 = 16 \Omega \text{ or } 4 \Omega$$

$$\text{Therefore, } R_1 = 4 \Omega \text{ or } 16 \Omega$$

30. With the help of the figure given below, find the currents flowing through the resistors and total current in the circuit.

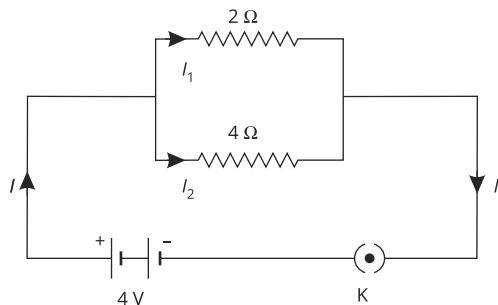

Ans. If the net resistance of the circuit is R , we have

$$\frac{1}{R} = \frac{1}{2} + \frac{1}{4}$$

$$\text{or } R = \frac{4}{3} \Omega$$

$$\text{Therefore, } I = \frac{V}{R} = \frac{4 \text{ V}}{\left(\frac{4}{3} \Omega\right)} = 3 \text{ A}$$

Total current in the circuit is 3 A

$$I_1 = \frac{3 \text{ A}}{\left(\frac{2 \times 3}{4}\right)} = 2 \text{ A}$$

$$I_2 = \frac{3 \text{ A}}{\left(\frac{4 \times 3}{4}\right)} = 1 \text{ A}$$

31. Consider the circuit diagram shown in the figure below. If $R_1 = R_2 = R_3 = R_4 = R_5 = 3 \Omega$, find the equivalent resistance of the circuit.

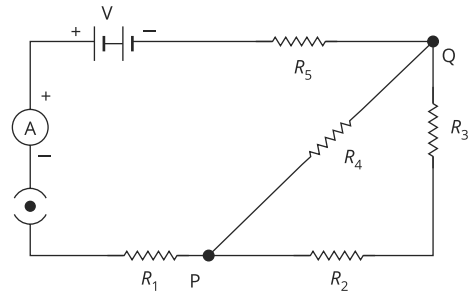

Ans. R_2 and R_3 are in series

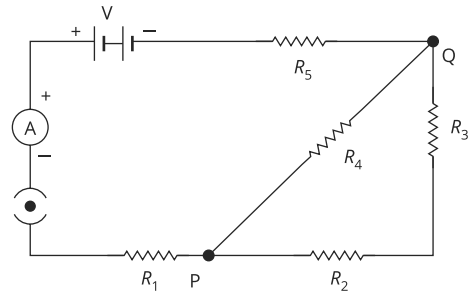

$$R_{23} = 3 \Omega + 3 \Omega = 6 \Omega$$

R_{23} and R_4 are parallel

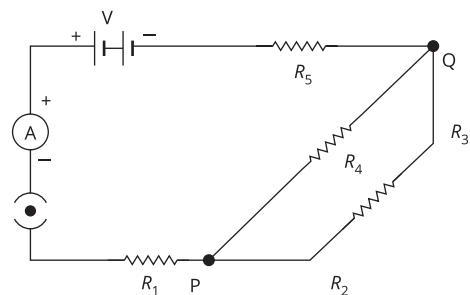

$$\frac{1}{R_{234}} = \frac{1}{R_{23}} + \frac{1}{R_4}$$

$$\text{or } \frac{1}{R_{234}} = \frac{1}{6} + \frac{1}{3} = \frac{3}{6}$$

$$\text{or } R_{234} = 2 \Omega$$

R_1 , R_{234} , and R_5 are in series

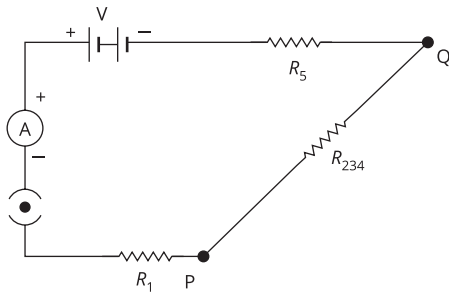

$$R_{12345} = R_1 + R_{234} + R_5$$

$$= 3 \Omega + 2 \Omega + 3 \Omega = 8 \Omega$$

Long Answer Type Questions

32. Two conductors A and B of resistances 5Ω and 10Ω , respectively, are first joined in parallel and then in series. In each case, the voltage applied is 20 V .
- Draw the circuit diagram to show the combination of these conductors in each case.
 - In which combination will the voltage across the conductors A and B be the same?
 - In which combination will the current through A and B be the same?
 - Calculate the equivalent resistance for each arrangement.

Ans. (a) The circuit diagrams are given below:

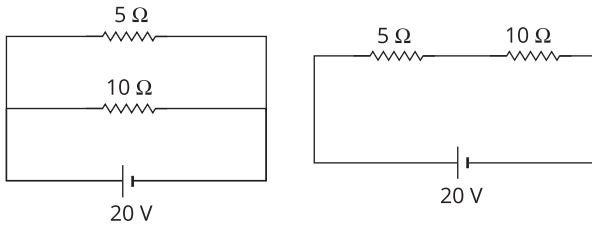

- The voltage across the two conductors is the same when they are combined in parallel.
- The current across the two conductors is the same when they are combined in series.

(d) $R_{\text{series}} = 5 \Omega + 10 \Omega = 15 \Omega$

$$\frac{1}{R_{\text{parallel}}} = \frac{1}{5} + \frac{1}{10}$$

or $R_{\text{parallel}} = \frac{10}{3} \Omega = 3.33 \Omega$

33. Five resistors are connected in a circuit as shown in the figure below. Find the ammeter reading when the circuit is closed.

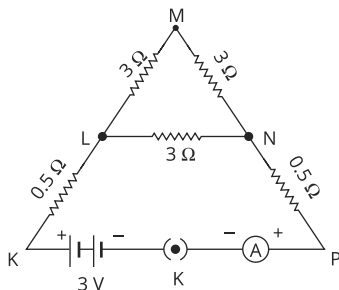

Ans. R_{LM} and R_{MN} are in series

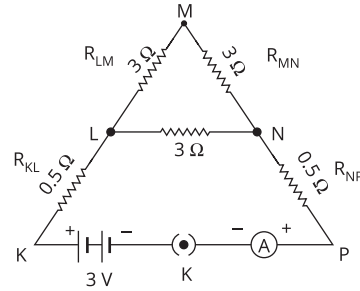

$$R_M = 3 \Omega + 3 \Omega = 6 \Omega$$

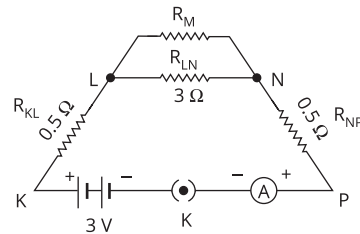

R_M and R_{LN} are in parallel

$$\frac{1}{R_{LMN}} = \frac{1}{6} + \frac{1}{3} = \frac{3}{6}$$

or

$$R_{LMN} = 2 \Omega$$

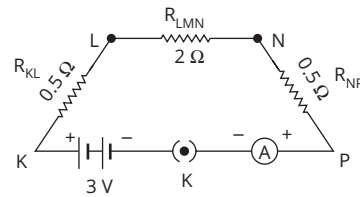

R_{KL} , R_{LMN} , and R_{NP} are in series.

Equivalent resistance of the circuit

$$= 0.5 \Omega + 2 \Omega + 0.5 \Omega$$

$$= 3 \Omega$$

$$\text{Ammeter reading} = \frac{3 \text{ V}}{3 \Omega} = 1 \text{ A}$$

34. (a) A current of 1 A flows in a series circuit containing an electric lamp and a conductor of 5Ω when connected to a 10 V battery. Calculate the resistance of the electric lamp.
- (b) Now, if a resistance of 10Ω is connected in parallel with this series combination, what change (if any) in current flowing through the 5Ω conductor and potential difference across the lamp will take place? Give reason.

Ans. (a) Equivalent resistance of the lamp and conductor combination in series = $\frac{10 \text{ V}}{1 \text{ A}} = 10 \Omega$

Therefore, resistance of the lamp = $10\ \Omega - 5\ \Omega$
 $= 5\ \Omega$

- (c) If a resistance of $10\ \Omega$ is connected in parallel, the equivalent resistance R is given by

$$\frac{1}{R} = \frac{1}{10} + \frac{1}{10}$$

or $R = 5\ \Omega$

Current flowing through the circuit,

$$I = \frac{10\text{ V}}{5\ \Omega} = 2\text{ A}$$

Since the resistance of the new resistance is the same as that of the lamp-conductor combination, the current flowing through the lamp = $\frac{2}{2} = 1\text{ A}$

Therefore, no change occurs in the current flowing through the conductor.

Let's Compete

(Page 87)

Multiple-Choice Questions

- If two conductors have the same potential, there will be
 - flow of electrons.
 - no flow of electrons.
 - flow of protons.
 - none of these.

Ans. The correct answer is (b).

- Which one of these is not used in verifying Ohm's law?
 - Ammeter
 - Rheostat
 - Voltmeter
 - Resistor

Ans. The correct answer is (d).

- If the area of cross section of a conductor is tripled, its resistance becomes
 - twice.
 - three times.
 - half.
 - one-third.

Ans. $R \propto \frac{1}{A}$

If area (A) is increased three times, the resistance decreases by 3 times or becomes $1/3^{\text{rd}}$. The correct answer is (d).

- An electrical fuse is connected with the electrical circuit
 - in parallel.
 - in series.
 - sometimes in parallel and sometimes in series.
 - none of these.

Ans. The correct answer is (b).

- In a voltmeter, there are 20 divisions between the 0 mark and the 0.5 V mark. The least count of the voltmeter is

- 0.020 V.
- 0.025 V.
- 0.050 V.
- 0.250 V.

Ans. Least count is = $\frac{0.5-0}{20} = 0.025\text{ m}$. The correct answer is (b).

- Four resistances, each of $10\ \Omega$, are connected to form a square. The equivalent resistance between two points on any one side is
 - $40\ \Omega$.
 - $20\ \Omega$.
 - $10\ \Omega$.
 - $7.5\ \Omega$.

Ans. If we consider two adjacent vertices, the side of the square between these points is in parallel combination with the series of three resistances across the three sides of the square.

Resistance of the three resistances, one across each side = $10\ \Omega + 10\ \Omega + 10\ \Omega = 30\ \Omega$... (i)

Resistance across the fourth side = $10\ \Omega$... (ii)

Resistances from (i) and (ii) are in parallel. If the equivalent resistance is R ,

$$\frac{1}{R} = \frac{1}{30} + \frac{1}{10} = \frac{4}{30}$$

Or $R = 7.5\ \Omega$

The correct answer is (d)

- The given circuit diagram shows the experimental arrangement of different circuit components for determination of the equivalent resistance of two resistors connected in series. The components X, Y and Z shown in the circuit, respectively, represent:

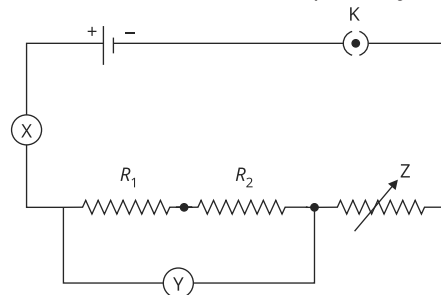

- Rheostat, Resistor, Ammeter
- Ammeter, Voltmeter, Rheostat
- Voltmeter, Ammeter, Rheostat
- Rheostat, Ammeter, Voltmeter

Ans. The correct answer is (b).

- For the two circuits shown below, the ammeter reading would be

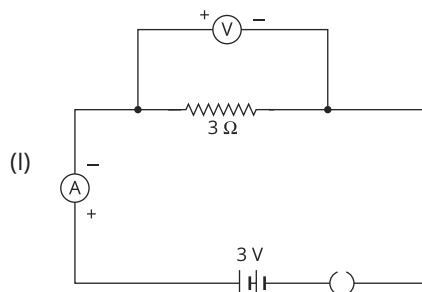

(I)

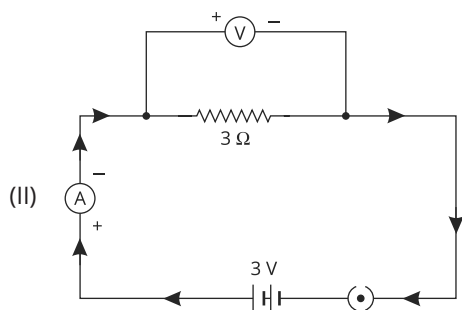

- (a) 1 A in both the circuits.
 (b) 1 A in circuit (I) and 0 A in circuit (II).
 (c) 0 A in circuit (I) and 1 A in circuit (II).
 (d) 0 A in both the circuits.

Ans. The switch is open in circuit (I), so no current flows through it. In circuit (II), the current is $\frac{3\text{ V}}{3\ \Omega} = 1\text{ A}$. The correct answer is (c).

9. The only correct statement for the electric circuit shown below is

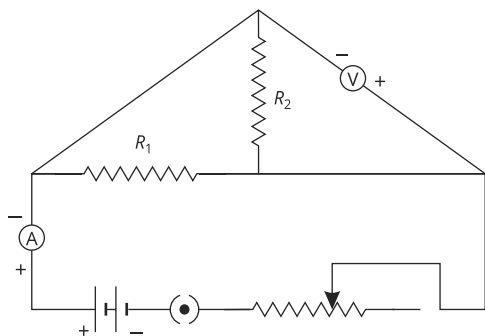

- (a) the voltmeter has been correctly connected in the circuit.
 (b) the ammeter has been correctly connected in the circuit.
 (c) the resistors R_1 and R_2 have been correctly connected in series.
 (d) the resistors R_1 and R_2 have been correctly connected in parallel.

Ans. The correct answer is (d).

10. In the circuit shown below, the current recorded by the ammeter is

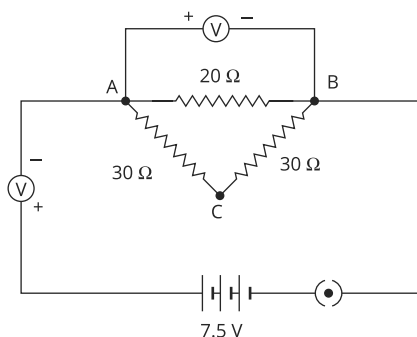

- (a) 0.25 A. (b) 0.50 A.
 (c) 0.75 A. (d) 1 A.

Ans. R_{AC} and R_{BC} are in series

$$\begin{aligned} R_{ACB} &= R_{AC} + R_{BC} \\ &= 30\ \Omega + 30\ \Omega \\ &= 60\ \Omega \end{aligned}$$

R_{ACB} and R_{AB} in parallel, so equivalent resistance R is given by

$$\frac{1}{R} = \frac{1}{60} + \frac{1}{20} = \frac{4}{60}$$

or $R = 15\ \Omega$

$$\text{Current in the circuit} = \frac{7.5\text{ V}}{15\ \Omega} = 0.5\text{ A}$$

The correct answer is (b).

Value-based Questions

(Optional) (Page 88)

1. Nikita sees her friend Monika ironing clothes with an electric press. Monika was barefooted. She advised Monika to wear rubber slippers. Monika followed her advice.

- (a) Why should we wear rubber slippers while working with electrical devices?
 (b) What are the values associated with Nikita's advice?

Ans. (a) Rubber is an insulator. When we wear rubber slippers while working with electrical devices, even if there is a leak of current through the device, the circuit cannot be completed with the ground as the rubber prevents the current from flowing through it. This way, we are saved from experiencing a shock.

- (b) We should care for the safety of others and should learn to use the concepts we study in classrooms in real life.

2. Aslam was visiting his grandfather, who lived in an ancestral house in a small town. He saw that the house used filament bulbs in all rooms. After a discussion with his grandfather, he went to the market with his father and got LED bulbs, and replaced the filament bulbs with these LED bulbs.

- (a) Why did Aslam replace the filament bulbs with LED bulbs?
 (b) What are the values associated with Aslam's action mentioned here?

Ans. (a) LED bulbs require much less power than filament bulbs for the same brightness because the latter involve wastage of a large amount of electrical energy as heat. LED bulbs also last longer. This

makes them cheaper in the long run, even if they cost more than filament bulbs.

- (b) We should always be willing to make the extra effort to help out our elders, especially those who are old. We should also understand the practical importance of lessons learnt in classrooms.
- 3. Tina was visiting her family's village house when one day all the lights in the evening switched off at the same time. Her uncle checked the fuse and changed the fuse wire, which had melted because of overloading. The lights were on again. Tina suggested that her uncle should replace the electric fuse with an MCB.

- (a) Why are MCBs (miniature circuit breakers) being used in houses nowadays?
- (b) What values are associated with Tina's suggestion?

- Ans.** (a) An MCB provides a number of advantages over an electrical fuse: it is more sensitive to current than a fuse; the faulty zone of the circuit can be identified more easily; it is easier to resume the supply; it is electrically safer and has lower maintenance and replacement cost.
- (b) We shouldn't hesitate to get involved if we can improve the way things are done. We should also be aware of developments that affect our daily lives.

Magnetic Effects of Electric Current

Checkpoint _____ (Page 91)

1. What is the lowest number of poles that a magnet can have?
 - (a) One
 - (b) Two
 - (c) Three
 - (d) Four

Ans. The correct answer is (b).

2. Which of these will happen when a magnetic compass is brought near a bar magnet?
 - (a) The needle of the compass will deflect
 - (b) The needle of the compass will not deflect
 - (c) The needle will reverse its direction
 - (d) The bar magnet will move away because of repulsion

Ans. The compass is originally oriented according to the magnetic field of the earth. When the compass is brought near a bar magnet, the stronger magnetic field starts acting on it. This causes deflection of the compass needle. The correct answer is (a).

3. The magnetic effect of current was first observed by which physicist?
 - (a) Isaac Newton
 - (b) Albert Einstein
 - (c) Michael Faraday
 - (d) Hans Christian Oersted

Ans. The correct answer is (d).

4. What happens to the needle of a magnetic compass when current flows in a wire close to the compass?

Ans. As was the case in question 2 above, the magnetic effect of the current causes a deflection in the needle of the compass.

5. In which direction does a freely suspended bar magnet always come to rest?

Ans. A freely suspended bar magnet always comes to rest in the North-South direction.

6. A wire is tightly wound around a nail in the form of a coil. When electric current flows through the wire, the nail behaves like a magnet, but loses its magnetism when the current is switched off. What is such type of temporary magnet known as?

Ans. Such type of temporary magnet is known as an electromagnet.

7. Name a common household device which uses the magnetic effect of current to function.

Ans. Electric bell, telephone, computer hard drive

8. Which terminal of a cell is represented by the longer line in its symbol in an electric circuit?

Ans. The positive terminal of a cell is represented by the longer line in the electrical circuit symbol.

9. What component of a circuit is denoted by the following symbol?

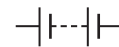

Ans. This is the symbol for a battery.

10. A lamp has a rating of 100 W at 220 V. What current is drawn from the line at 220 V supply voltage?

Ans. Power = $V \times I$

$$\begin{aligned}
 \text{or} \quad I &= \frac{\text{Power}}{V} \\
 &= \frac{100 \text{ W}}{220 \text{ V}} \\
 &= 0.45 \text{ A}
 \end{aligned}$$

Milestone 1

(Page 98)

Multiple-Choice Questions

- As we move away from a current-carrying conductor, the spacing between the magnetic field lines
 - increases.
 - decreases.
 - remains equidistant.
 - becomes parallel.

Ans. Wider spacing between magnetic field lines indicates a weak magnetic field. As we move away from a current-carrying conductor, the strength of the magnetic field because of it decreases (as $B \propto 1/r$). Therefore, the correct answer is (a).

- The core of an electromagnet is
 - steel.
 - magnesium.
 - soft iron.
 - copper.

Ans. The correct answer is (c).

- An electric current passes through a straight wire. Magnetic compasses are placed at the points A and B.

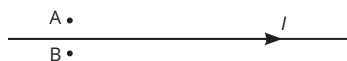

- Their needles will not deflect.
- Only one of the needles will deflect.
- Both the needles will deflect in the same direction.
- The needles will deflect in the opposite directions.

Ans. The correct answer is (d).

- The magnetic field lines due to a straight wire carrying a current are
 - straight.
 - circular.
 - parabolic.
 - elliptical.

Ans. The correct answer is (b).

- The magnetic field lines inside a long current-carrying solenoid are nearly
 - straight.
 - circular.
 - parabolic.
 - elliptical.

Ans. The correct answer is (a).

- If there is a circular coil having n turns, the magnetic field produced is as large as when produced by a simple turn of
 - n times.
 - $\frac{n}{2}$ times.
 - $2n$ times.
 - $\frac{n}{4}$ times.

Ans. The correct answer is (a).

- The right-hand thumb rule gives the
 - strength of magnetic field.
 - direction of magnetic field.
 - intensity of magnetic field.
 - power of magnetic field.

Ans. The correct answer is (b).

Very Short Answer Type Questions

- Is magnetic field at any point in space a scalar or a vector quantity?

Ans. Magnetic field is a vector quantity.

- A current passes through a wire from south to north. What will be the direction of the magnetic field at a point vertically above the wire?

Ans. Using the Maxwell's corkscrew rule, the direction of the magnetic field vertically above the wire is from west to east.

- Is there any change in the deflection of compass needle as we move along a magnetic field line?

Ans. No, if we move along a magnetic field line, there is no change in the deflection of a compass needle.

- A circular loop carrying a current is placed on a horizontal surface. As seen from above, the current is in the clockwise direction. What is the direction of its magnetic field at the centre?

Ans. According to Maxwell's corkscrew rule, the direction of the magnetic field will be into the surface.

Short Answer Type-I Questions

- How can you increase the intensity or strength of the magnetic field of a current-carrying solenoid?

Ans. The intensity of the magnetic field of a current-carrying solenoid can be increased by:

- Increasing the number of turns of the coil
- Increasing the strength of the current flowing through the coil
- Using a soft iron core along the axis of the solenoid

13. What happens when a freely suspended current-carrying solenoid
- comes to rest?
 - is brought near iron filings?

Ans. (a) When a freely suspended current-carrying solenoid comes to rest, it suspends itself in the north-south direction.

(b) When a freely suspended current-carrying solenoid is brought near iron filings, the filings arrange themselves in the pattern of magnetic field lines.

14. How can you say that the magnetic field is the same at all points inside a current-carrying solenoid?

Ans. We can say this because the magnetic field lines inside the solenoid are nearly parallel to each other.

15. List three sources of magnetic fields.

Ans. Four sources of magnetic fields are:

- A permanent magnet
- A current-carrying wire
- A current-carrying solenoid

Short Answer Type-II Questions

16. Draw a diagram to show magnetic field lines
- formed when unlike poles of two bar magnets face each other
 - formed when like poles of two bar magnets face each other.

Ans. The images given below show the magnetic field lines when (a) unlike poles of two bar magnets face each other and (b) when like poles of two bar magnets face each other.

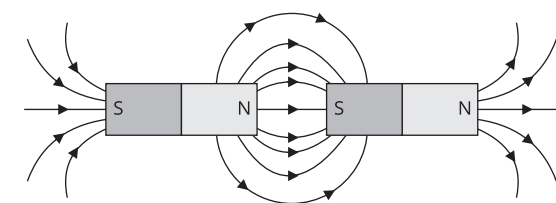

Attraction between opposite poles

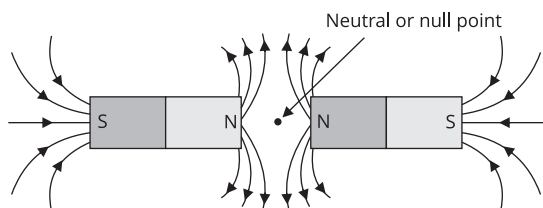

Repulsion between like poles

17. Draw a sketch to show the magnetic field lines due to a
- straight current-carrying wire
 - circular current-carrying wire.

Ans. (a) The following figure shows the magnetic field lines due to a straight current-carrying wire:

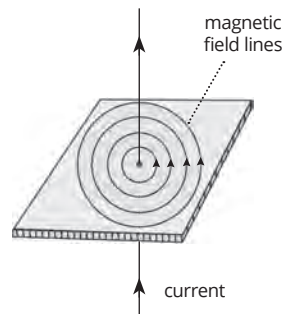

(b) The following figure shows the magnetic field lines due to a circular current-carrying wire:

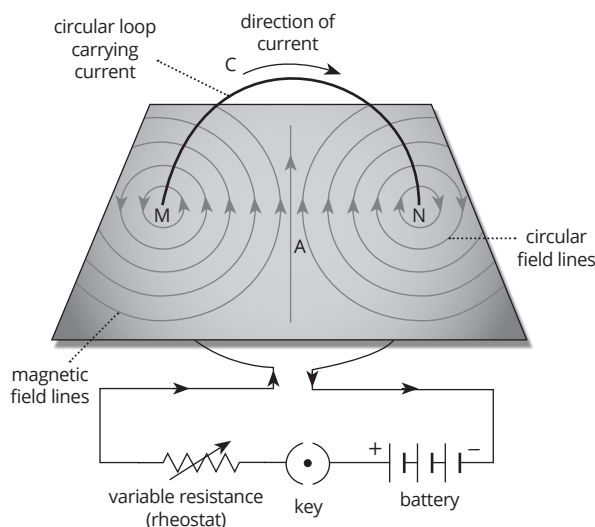

18. Knowing the direction of the current, how will you determine the side on which the north pole is formed in an electromagnet?

Ans. Taking the convention that current flows from the positive end of the battery to the negative end, we wrap the fingers of our right hand in the direction positive current flows through the coils of the electromagnet. Then our thumb, when we stick it out, will point in the direction of the magnetic field, which points along local magnetic north.

Long Answer Type Questions

19. What are the important differences between an electromagnet and a permanent magnet?

Ans. Refer to Table given on next page.

Differences between an electromagnet and a permanent magnet

Parameter	Electromagnet	Permanent magnet
1. Nature of magnetism	It shows temporary magnetism. It produces the magnetic field as long as current flows in its coil.	It shows permanent magnetism, i.e. it retains magnetism in it even when the current is switched off.
2. Polarity	The polarity of an electromagnet can be changed by reversing the direction of the current.	The polarity of a permanent magnet cannot be changed.
3. Strength of the magnetic field	The strength of the magnetic field can be increased or decreased by changing the strength of the current or the number of turns in the coil.	The strength of the magnetic field cannot be changed.
4. Demagnetisation	An electromagnet can easily be demagnetised by switching off the current in the solenoid.	It cannot be easily demagnetised.
5. Magnetic field	It can produce a strong magnetic field.	It cannot produce a very strong magnetic field.
6. Nature of material	It is a solenoid with a soft iron core.	It is made of steel.

20. Draw a diagram to show what happens to a compass needle when placed below a current-carrying wire when

- no current is passing through the wire.
- current is passing through the wire.
- current is increased.
- current is reversed.

Ans. The following diagrams show what happens to a compass needle when it is placed below a current-carrying wire:

- When no current is passed through the wire, the needle aligns itself in the north-south direction.
- When current begins passing through the wire, the needle deflects.
- When current is increased, the deflection increases.
- When current is reversed, the deflection takes place in the opposite direction.

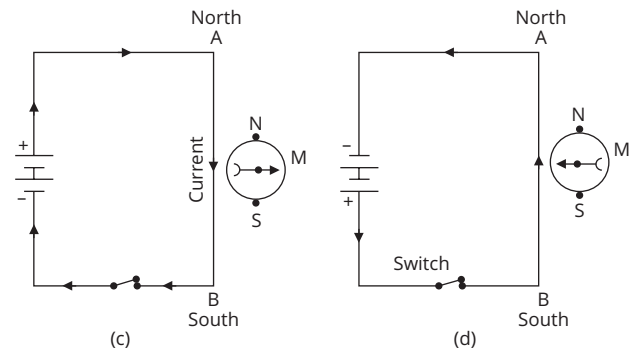
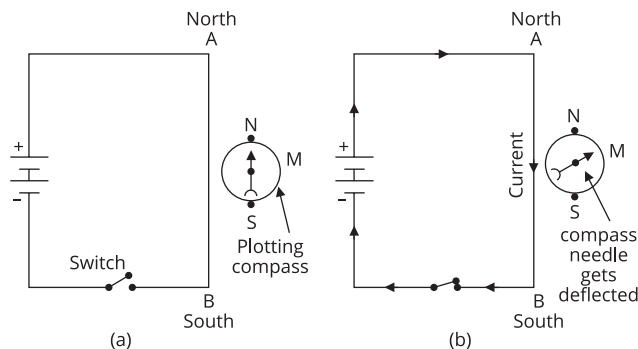

Milestone 2

(Page 107)

Multiple-Choice Questions

- An electron enters a magnetic field at right angles to it, as shown below. The direction of force acting on the electron will be
 - to the right.
 - to the left.
 - out of the page.
 - into the page.

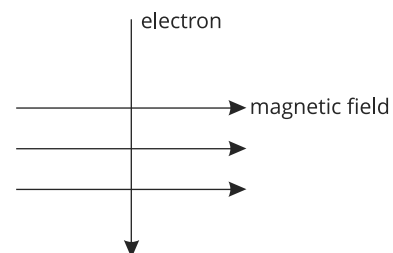

Ans. The direction of current is opposite to the direction of flow of electrons. Using Fleming's left

hand rule for current flowing vertically upwards and magnetic field from left to right, the direction of the force will be into the page. The correct answer is (d).

2. An electric current can be produced in a closed loop
- by connecting it to a battery, but not by moving a magnet near it.
 - by moving a magnet near the loop, but not by connecting a battery.
 - by connecting it to a battery, as well as by moving a magnet near it.
 - neither by connecting a battery nor by moving a magnet near it.

Ans. The correct answer is (c).

3. What is the force acting on a charge moving along the direction of the magnetic field?
- Infinity
 - One
 - Zero
 - None of these

Ans. The correct answer is (c).

4. Induced current is produced in a coil by the change of
- electric field.
 - magnetic field.
 - electromagnetic field.
 - none of these.

Ans. The correct answer is (b).

5. An AC generator is connected to an electric appliance. In 10 revolutions of the armature, the current in the appliance changes direction
- 5 times.
 - 10 times.
 - 20 times.
 - 40 times.

Ans. In the working of an AC generator, we have seen that for one revolution of the armature to complete, the current changes direction twice. Therefore, for 10 revolutions, the current changes direction 20 times. The correct answer is (c).

6. A commutator changes the direction of current in the coil of
- a DC motor.
 - a DC motor and an AC generator.
 - a DC motor and a DC generator.
 - an AC generator.

Ans. The correct answer is (a).

7. An electric fuse can prevent accidents arising from
- an overload but not due to a short circuit.
 - a short circuit but not due to an overload.
 - an overload as well as a short circuit.
 - neither an overload nor a short circuit.

Ans. The correct answer is (c).

Very Short Answer Type Questions

8. A vertical wire is carrying a current in the upward direction. It is placed in a magnetic field pointing towards the east. What is the direction of the force on the wire?

Ans. Using Fleming's left-hand rule, the direction of the force will be perpendicular to the directions of the current and the magnetic field and will be towards the north.

9. A beam of electrons can be thought of as an electric current whose direction is opposite to the direction of the moving electrons. Suppose you find that an electron beam coming towards you horizontally through a magnetic field gets deflected towards the right. What is the direction of the magnetic field that bends the beam?

Ans. The electron beam is in our direction horizontally, which means the current flows away from us. With the middle finger pointing away from us horizontally and the thumb (force) pointed towards the right, the forefinger points upward, which gives the direction of the magnetic field.

10. A motor converts energy from one form to another. Name the two forms.

Ans. A motor converts electrical energy into kinetic energy.

11. What is the colour convention for live, neutral and earth wires?

Ans. Live: red, neutral: black, and earth: green

Short Answer Type-I Questions

12. What is the basic difference between an AC and a DC generator?

Ans. The basic difference between an AC and a DC generator is that in the former, the direction of the induced current in each side of the coil is reversed after half a rotation while in the latter, the direction of the induced current in the entire circuit never changes.

13. Can a magnetic field be produced without using a magnet? If yes, how?

Ans. Yes, a magnetic field can be produced without using a magnet. This can be done by passing current through a wire, coil, or solenoid.

14. An electric heater is rated 2 kW, 220 V. If a fuse is to be connected to it, should it be rated 5 A or 15 A?

Ans. Power = $V \times I$

$$\text{or } I = \frac{200 \text{ W}}{220 \text{ V}} = 9.1 \text{ A}$$

The fuse has to allow at least this much current to pass through so that the heater is able to function

properly. Therefore, it should be rated 15 A.

15. What is the function of split rings and carbon brushes in an electric motor?

Ans. The split rings and carbon brushes in an electric motor complete the circuit between the source and the armature, thus, ensuring that the current flows through the coil to make it rotate.

16. How can the speed of rotation of the coil in an electric motor be increased?

Ans. The speed of rotation of the coil in an electric motor can be increased by the following means:

- (a) Increasing the amount of current flowing in the coil
- (b) Increasing the number of turns in the coil
- (c) Increasing the area of cross-section of the coil
- (d) Increasing the strength of the radial magnetic field
- (e) Laminating the soft iron core.

Short Answer Type-II Questions

17. A coil of insulated wire is connected to a galvanometer. What would be seen if a bar magnet with its north pole towards one face of the coil is

- (a) moved quickly towards it.
- (b) moved quickly away from the coil.
- (c) placed near it one face.

What is the phenomenon involved here?

Ans. (a) If the north pole of the magnet is facing the north pole of the coil, when the bar magnet is moved quickly towards the coil, the galvanometer's needle gets deflected toward the magnet.

(b) If the magnet is removed quickly away from the coil, the needle of the galvanometer gets deflected away from the magnet.

(c) If the magnet is placed near one face of the coil, there is no deflection in the needle of the galvanometer.

The phenomenon involved in electromagnetic induction.

18. What is the function of the following in an AC generator?

- (a) Armature
- (b) Slip rings
- (c) Brushes

Ans. (a) The armature consists of a large number of turns of insulated wire wound over a soft iron core. It is here that current is induced when the armature rotates in the magnetic field of the strong permanent magnet.

(b) The slip rings are two hollow rings connected to the ends of the armature. These rings rotate with the armature and allow for electrical contact with the brushes.

(c) The carbon brushes press against the slip rings, but remain fixed. The current induced in the armature is taken out into the circuit through these brushes.

Long Answer Type Questions

19. Draw a schematic labelled diagram of a domestic wiring circuit which includes

- (a) a main fuse
- (b) a power meter
- (c) one light point
- (d) a power output socket.

In this circuit, on which wire of the circuit is the mains on/off switch connected?

Ans. The following schematic shows the required circuit. The mains on/off switch is connected to the wire coming out of the power meter.

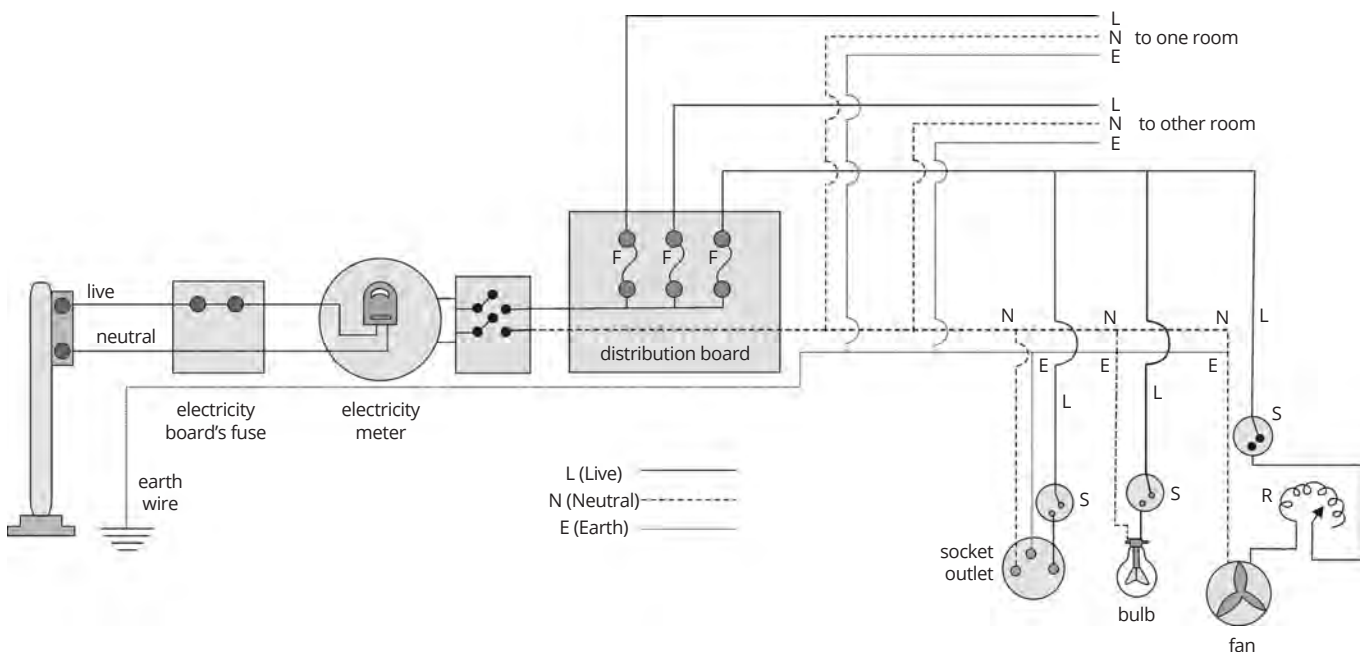

20. What is the meaning of overloading and short circuit? What precautions should be taken to avoid the overloading of domestic electric circuits?

Ans. Overloading of an electrical circuit refers to a flow of a large amount of current in the circuit beyond its permissible current rating. It can occur either by connecting too many appliances of high power ratings in a single circuit or due to an accidental hike in the supply voltage.

A short circuit is said to take place if the live wire and the neutral wire somehow come into direct contact. This can result in an abrupt increase in the current in the circuit, damaging the circuit and any connected appliances.

A fuse or an MCB must be used to avoid damage due to overloading. We should also be careful about not switching on too many high rating appliances at the same time.

Higher Order Thinking Skills (HOTS) Questions

(Page 110)

1. A magnetic needle is placed over a strong and large bar magnet and made to move freely about a vertical axis passing through its centre. In which direction will the magnetic needle come to rest?

Ans. The magnetic needle will lie parallel to the bar magnet. The north pole of the needle will be pointing towards the south pole of the bar magnet and vice versa.

2. Why is it not advisable to handle domestic electric circuits with wet hands?

Ans. The wet human body is a good conductor of electricity, so by touching a switch or socket or an electrical appliance with a metallic body, one is likely to get a severe shock.

3. What will happen to the poles of a bar magnet if it is broken into two pieces?

Ans. When a bar magnet is broken into two pieces, each piece acts as a complete bar magnet with north and south poles. This is because a magnetic monopole doesn't exist in nature.

4. When a proton moves freely in a magnetic field, which of its properties will change?

Ans. When a proton moves freely in a magnetic field, the direction of its motion and, hence, its velocity changes. This will also change properties related to velocity, namely, momentum.

5. A magnetic field deflects a positively charged α -particle travelling along west towards the north. What is the direction of the magnetic field?

Ans. The positively charged particle is travelling towards the west, which means that the current is flowing towards the west. The force acts towards the north. Using Fleming's left hand rule, the direction of the magnetic field is upwards.

6. Two circular coils A and B are placed nearby. If current in coil A is changed, will there be a change in current in coil B also?

Ans. When the current in coil A is changed, the magnetic field around it is changed. As a result, the number of field lines passing through the neighbouring coil B changes and consequently, the current in coil B also changes.

7. A student performs an experiment to study the magnetic effect of current around a straight current-carrying conductor. He reports that

(a) the direction of deflection of the north pole of a compass needle kept at a given point near the conductor remains unaffected even when the terminals of the battery sending current in the wire are interchanged.

(b) for a given battery, the degree of deflection of N-pole decreases when the compass is kept at a point farther away from the conductor.

Which of the above observations is incorrect and why?

Ans. The first observation is incorrect because on reversing the direction of current flow, the direction of a magnetic field and, hence, the direction of deflection of the N-pole of the needle must be reversed.

8. Why does a current-carrying solenoid, when suspended freely, rest along a particular direction?

Ans. A current-carrying solenoid acts as a temporary magnet. Like any magnet suspended freely, the current-carrying solenoid also rests along the north-south direction because of earth's magnetic field.

Self-Assessment

(Page 110)

Multiple-Choice Questions

1. Which of the following involves electromagnetic induction?

- (a) A rod is charged with electricity
- (b) An electric current produces a magnetic field
- (c) A magnetic field exerts a force on a current-carrying conductor
- (d) The relative motion between a magnet and a coil produces an electric current

Ans. The correct answer is (d).

2. An electric motor
- provides a constant potential difference.
 - measures electric current.
 - measures potential difference.
 - converts electrical energy into kinetic energy.

Ans. The correct answer is (d).

3. In electric fittings in a house
- the live wire goes through the switch.
 - the neutral wire goes through the switch.
 - the earth wire goes through the switch.
 - no wire goes through the switch.

Ans. The correct answer is (a).

4. In an AC generator, a coil wound over a soft iron core is called
- slip ring.
 - brush.
 - armature.
 - field magnet.

Ans. The correct answer is (c).

5. When live wire and neutral wire come in direct contact, it leads to
- short circuiting.
 - earthing.
 - stoppage of electric current.
 - none of these.

Ans. The correct answer is (a).

Assertion–Reason Type Questions

For question numbers 6 to 15, two statements are given – one labelled Assertion (A) and the other labelled Reason (R). Select the correct answer to these questions from the codes (a), (b), (c) and (d) as given below.

- Both A and R are true and R is the correct explanation of the assertion.
 - Both A and R are true but R is not the correct explanation of the assertion.
 - A is true but R is false.
 - A is false but R is true.
6. **Assertion:** The direction of magnetic field lines, outside the magnet, is from the north pole to the south pole.
Reason: The north pole of a magnet always has a stronger magnetic field around it than the south pole.
- Ans.** (c)
7. **Assertion:** For a straight current-carrying conductor, the plane of the magnetic field lines is parallel to the conductor.

Reason: For a straight current-carrying conductor, the magnetic field lines form a series of concentric circles around the conductor.

Ans. (d)

8. **Assertion:** When the flow of current through a solenoid with a soft iron core is switched off, the solenoid loses its magnetic properties.

Reason: Soft iron has low retentivity.

Ans. (a)

9. **Assertion:** Direct current is used to provide electricity to homes.

Reason: Alternating current cannot be used for important purposes like electrolysis, electroplating and electrotyping.

Ans. (d)

10. **Assertion:** A magnetic field has no effect on a stationary charge.

Reason: A moving charge produces a magnetic field.

Ans. (a)

11. **Assertion:** A DC motor converts electrical energy into mechanical energy.

Reason: A motor works on the principle of electromagnetic induction.

Ans. (c)

12. **Assertion:** When an electron and a proton enter a magnetic field with the same velocity, the force experienced by the proton is much greater than that experienced by the electron.

Reason: A proton is more than a thousand times heavier than an electron.

Ans. (d)

13. **Assertion:** When there is relative motion between a coil and a magnet placed close to it, current is induced in the coil.

Reason: If the relative speed between the coil and the magnet increases, the strength of the induced current increases as well.

Ans. (b)

14. **Assertion:** Electrical connections to different rooms in a house are done in parallel.

Reason: In the tree system of distribution of power, even if the fuse of one room blows off, electricity supply to other circuits is not affected.

Ans. (a)

15. **Assertion:** It is possible for a current-carrying conductor placed in a magnetic field to not experience any force because of the field.

Reason: If a current-carrying conductor is placed perpendicular to the magnetic field, the conductor experiences no force.

Ans. (c)

Source-based/Case-based/Passage-based/ Integrated Questions

Answer the questions on the basis of your understanding of the following paragraphs and the related studied concepts.

16. The use of electromagnets to lift ferrous materials is very popular in industry, as it allows easy sorting in a mixture of ferrous and non-ferrous materials and can also be used to lift heavy ferrous objects with relatively low supply of current. The equation for the lifting force of an electromagnet is given by:

$$F = \frac{(nl)^2 \mu_0 A}{2g^2}$$

Where n = number of turns; l = current; μ_0 = the permeability of air ($4\pi \times 10^{-7}$ units); A = cross-sectional area of the coil core; g = the gap between the electromagnet and the object to be lifted.



- I. (a) If an iron object of mass 800 kg is to be lifted from a distance of 2 mm, using a coil of 2000 turns and coil core of diameter 6 mm, what is the amount of current required? [Take acceleration due to gravity to be 10 m/s^2]
- (b) Theoretically, how much mass can thrice this amount of current lift?
- (c) Materials with high permeability allow magnetic flux through more easily than other materials. What is the equivalent property of a material in relation to passage of electrical current through the material?
- (d) How does the intensity of the magnetic field due to the current carrying coil change with the number of turns and the magnitude of current?

Ans. (a) 21.23 A

(b) 7,200 kg

(c) Conductivity

(d) Directly proportional to both

- II. (a) Electromagnets are used in the construction of
- (i) electric bells.

- (ii) loudspeakers.
(iii) electric fans.
(iv) all of the above.

Ans. (iv) all of the above.

- (b) Which of the following is not a magnetic substance?

- (i) Iron
(ii) Copper
(iii) Nickel
(iv) Cobalt

Ans. (ii) Copper

- (c) Which of the following is a ferromagnetic material?

- (i) Gold
(ii) Aluminium
(iii) Silver
(iv) Nickel

Ans. (iv) Nickel

- (d) What is the most effective and quickest method for making a magnet from soft iron?

- (i) By placing it inside a coil carrying current
(ii) By electromagnetic induction
(iii) By the use of permanent magnet
(iv) By rubbing with another magnet

Ans. (i) By placing it inside a coil carrying current

- (e) The most suitable material for making the core of an electromagnet is

- (i) copper.
(ii) bronze.
(iii) soft iron.
(iv) steel.

Ans. (iii) soft iron.

17. A transformer is basically made up of a laminated iron core with two coils that are not connected. The primary coil receives the input and the secondary coil gives the output voltage from the transformer. In a generator, the magnitude of the induced emf depends upon the magnetic field strength, the generator speed, and the length of the wire in the

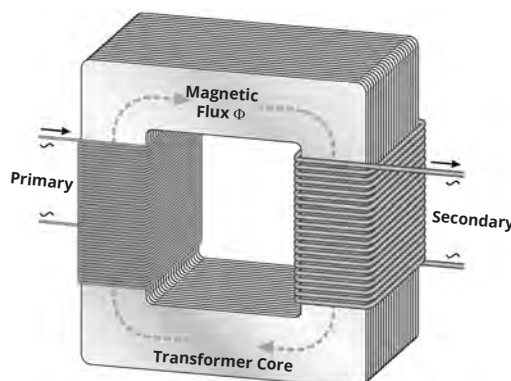

field. For a transformer, the first two quantities are equal for both the primary and the secondary coil. However, the number of turns of the coils can differ, and thus, the emf in the two coils can be different. For instance, if the secondary coil has five times the number of turns as the primary coil, the induced emf in the secondary coil will be five times the supplied emf to the primary coil. This is how a step-up transformer functions. For a step-down transformer, the number of turns in the secondary coil will be less than that in the primary coil. Thus, $V_S/V_P = N_S/N_P$.

- I. (a) In a step-up transformer, if the voltage output is higher than the input, does it also mean that the current produced is higher than the input? What fundamental principle tells us that this is not possible?
- (b) Assuming 100% energy efficiency, what would be the relation between current in each coil and number of turns in each coil?
- (c) The primary coil of a step-transformer has 150 turns and the secondary coil has 1800 turns. If the input to the primary coil is 3.60 kW at 250 V, what is the voltage output from the secondary coil?
- (d) What is the current output from the secondary coil for the conditions in (c)? [Assume 100% efficiency]

Ans. (a) No, Principle of conservation of energy

$$(b) \frac{I_S}{I_P} = \frac{n_P}{n_S}$$

- (c) 3000 V
(d) 1.2 A

- II. (a) Generator is based on the principle of
- electromagnetic induction.
 - induced current.
 - induced magnetism.
 - Faraday effect.

Ans. (i) electromagnetic induction.

- (b) A generator produces electricity. It is a source of
- gravity.
 - magnetism.
 - emf.
 - electrolysis.

Ans. (iii) emf.

- (c) AC generator converts
- mechanical energy to electrical energy.
 - sound energy to electrical energy.
 - electrical energy to mechanical energy.
 - none of the above.

Ans. (i) mechanical energy to electrical energy.

- (d) On which factor does the electromotive force developed by the generator depend?
- Area of rotating wire
 - Length of rotating wire
 - Radius of wire
 - Size of magnet

Ans. (ii) Length of rotating wire

- (e) For a step-down transformer, the number of turns in the secondary coil will be
- same as that in the primary coil.
 - less than that in the primary coil.
 - more than that in the primary coil.
 - none of the above.

Ans. (ii) less than that in the primary coil.

Very Short Answer Type Questions

18. Name two factors that completely define a magnetic field at a point.

Ans. The strength of the magnetic field and its direction are the two factors that completely define the magnetic field at a point.

19. How can it be shown that a magnetic field exists around a wire through which a direct current is passing?

Ans. When a magnetic compass is brought near the wire, the needle of the compass deflects. This shows that there is a magnetic flux around the wire carrying direct current.

20. An alternating electric current has a frequency of 50 Hz. How many times does it change its direction in one minute?

Ans. Time period = 1/frequency = 1/50 Hz = 0.02 s
Therefore, in 0.02 s, the current changes its direction 2 times

In 60 s, the number of directions changes is $\frac{2}{0.02} \times 60 = 6000$ times

21. In the following figure identify the poles marked P and Q as north pole or south pole. Give reason.

Ans. The magnetic field lines in the figure originate from P and end at Q. This behavior corresponds with P being the north pole and Q being the south pole.

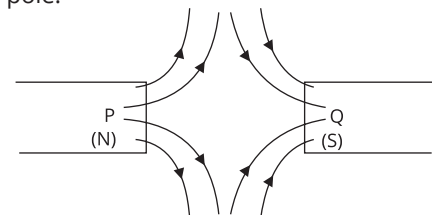

22. What does the divergence of magnetic field lines near the ends of a current-carrying straight solenoid indicate?

Ans. The divergence of magnetic field lines near the ends of a current-carrying solenoid indicates that the strength of the magnetic field near the ends is weaker compared to that at the centre of the solenoid.

Short Answer Type-I Questions

23. AB is a current-carrying conductor in the plane of the paper as shown in the figure below. What are the directions of magnetic field produced by it at points P and Q? Given $r_1 > r_2$, where will the strength of the magnetic field be larger. Justify your answer in each case.

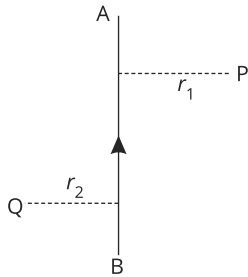

Ans. Applying the right-hand thumb rule, we can see that the magnetic field at P is directed into the plane of the paper while the field at Q is directed outward from the plane of the paper. Since the strength of magnetic field is inversely proportional to distance, if $r_1 > r_2$, the field strength at Q is larger than that at P.

24. In the above question, if $I = 5$ A, $r_1 = 1.5$ cm and $r_2 = 1$ cm, compare the magnetic field at points P and Q.

Ans. We know that $B \propto 1/r$. Since I is common for both the points, we have

$$B_P/B_Q = r_2/r_1 = \frac{1 \text{ cm}}{1.5 \text{ cm}} = \frac{2}{3}$$

25. Name the type of electric current generated by most of the power stations in India. Why is it preferred over the other type of electric current?

Ans. Alternating current is generated by most of the power stations in India. It is preferred over direct current because:

- AC generators are easy to operate and maintain.
- In an AC circuit, the voltage can be suitably increased or decreased with the help of a transformer.
- AC electric power can be transmitted over long distances without much loss of energy.

26. How is a solenoid different from a coil?

Ans. The main difference between a solenoid and a coil is that in the former the length is much greater than the diameter, while in the latter, the

length and diameter are comparable. The distance between loops is also greater than it is in a coil.

27. Describe an activity to show how an iron nail can be magnetised.

Ans. An iron nail can be magnetised using the concept of electromagnetism. The method requires a length of insulated copper wire, some pliers, and a battery or series of batteries taped together. We expose about an inch of copper wire from either end of the wire, and wrap the middle portion of the wire tightly about the nail. More wraps of wire will give us a stronger magnet. Then, we attach each exposed end of the copper wire to opposite battery terminals to complete the electromagnet.

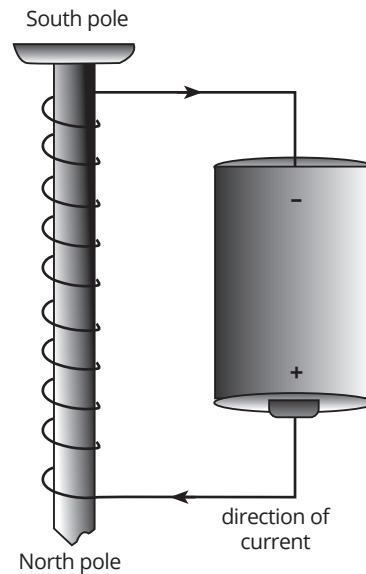

Short Answer Type-II Questions

28. The following figure depicts three diagrams showing entry of an electron in a magnetic field. Identify the case in which the force on the electron will be maximum and minimum respectively. Give reason for your answer. Find the direction of maximum force acting on the electron.

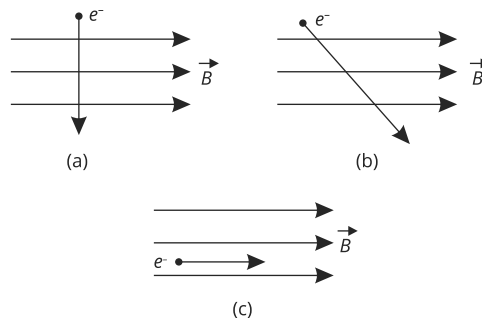

Ans. The force acting on the electron will depend on the sine of the angle between the direction of

current and the direction of the magnetic field. The direction of current is exactly the opposite of the direction of motion of the electron. Therefore, the force on the electron is maximum in (a) as the angle between current and magnetic field here is 90° . The force is minimum in (c) because the angle here is 180° . In (a), the direction of current is towards the north and the direction of magnetic field is towards the east. Using Fleming's left-hand rule, the direction of the force will be into the plane of the paper.

29. Two insulated copper circular coils P and Q are kept close to each other, of which, coil P carries a current. If coil P is moved towards Q, will some current be induced in coil Q? Give reason for your answer and name the phenomenon involved. What happens if coil P is moved away from coil Q?

Ans. When the current-carrying coil P is moved towards coil Q, an induced current is set-up in Q. As P moves towards Q, more magnetic field lines, produced due to P, pass through Q and consequently, an induced current is set-up in Q due to electromagnetic induction.

If P is moved away from Q, the number of magnetic field lines passing through Q decreases and an induced current is set-up in Q again. However, the direction of the induced current in Q now will be opposite to the direction of current earlier.

30. Explain different ways to induce current in a coil.

Ans. Different ways to induce current in a coil are:

- Move a permanent magnet to and fro close to the coil. Relative motion between the magnet and the coil induces an electric current in the coil.
- Place a current-carrying coil close to the coil. Changing the current flowing through this neighbouring coil will induce current in the original coil.

Long Answer Type Questions

31. (a) The following figure shows a domestic electric circuit. Study the circuit carefully and list the errors in the circuit. Justify your answer.

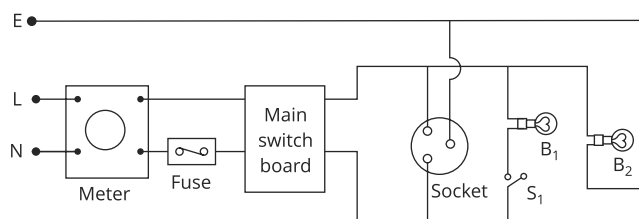

- (b) Give one difference between the wires used in the element of an electric heater and in a fuse.

Ans. (a) The errors in the given domestic circuit are as follows:

- The fuse has been connected to the neutral wire N when it should be connected to the live wire L.
 - There is no switch provided with the three-pin socket.
 - The switch S_1 with the bulb B_1 is connected with the neutral wire when it should be connected to the live wire.
 - The bulb B_2 is connected to the earth wire and the live wire when it should be connected to the neutral wire and the live wire.
 - There is no switch provided with the bulb B_2 .
- (b) The wires used in the element of an electric heater have a high melting point while those used in fuses have a low melting point.

32. Compare a DC generator with an electric motor.

Ans. Differences between a DC generator and an electric motor:

Parameter	DC Generator	Electric Motor
1. Energy conversion	Mechanical energy is converted into electrical energy	Electrical energy is converted into mechanical energy
2. Direction	Direction of induced current is given by Fleming's right-hand rule	Direction of motion of conductor is given by Fleming's left-hand rule

Let's Compete

(Page 113)

1. The frequency of an alternating current if its direction changes after every 0.02 s is
- 10 Hz
 - 25 Hz
 - 50 Hz
 - 100 Hz

Ans. If the direction of the AC changes after every 0.02s, its time period is 0.04 s.

$$\text{Frequency} = \frac{1}{0.04 \text{ s}} = 25 \text{ Hz.}$$

Therefore, the correct answer is (b).

2. Which of the following describes the common domestic power supplied in India?
- 220 V, 100 Hz
 - 110 V, 100 Hz
 - 220 V, 50 Hz
 - 110 V, 50 Hz

Ans. The correct answer is (c).

3. A copper ring having a cut, so as not to form a complete loop, is held horizontally. A bar magnet

is dropped through the ring with its length along the axis of the ring. The acceleration of the falling magnet is

- (a) g (b) less than g
(c) more than g (d) 0

Ans. The only force acting on the magnet is because of the earth's gravitational field. The copper loop is cut, so there is no current flowing through it and there is no induced magnetic field. Therefore, the correct answer is (a).

4. A device that can be used to produce an electric current in a circuit is

- (a) an ammeter. (b) a motor.
(c) a generator. (d) a galvanometer.

Ans. The correct answer is (c).

5. A magnet is moved towards a coil (i) quickly and (ii) slowly. The induced emf

- (a) is larger in case (i). (b) is smaller in case (ii).
(c) is equal in both cases. (d) cannot be predicted.

Ans. The correct answer is (a).

6. An electric bulb rated 220 V is connected to 220 V, 5 Hz AC source. The bulb

- (a) does not glow. (b) glows intermittently.
(c) glows continuously. (d) gets fused.

Ans. The bulb will glow properly at 50 Hz AC supply. At a lower frequency, it will keep flickering. Therefore, the correct answer is (b).

7. When a charged particle moving with velocity v is subjected to a magnetic field B , the force on it is non-zero. This implies that

- (a) angle between them is either 0° or 180° .
(b) angle between them is necessarily 90° .
(c) angle between them can have any value other than 90° .
(d) angle between them can have any value other than 0° and 180° .

Ans. Since we have to ensure that the sine value of the angle is non-zero, the correct answer is (d).

8. The magnetic field at a distance r from a long wire carrying current I is 0.4 T. The magnetic field at a distance $2r$ is

- (a) 0.1 T (b) 0.2 T
(c) 0.8 T (d) 1.6 T

Ans. We know that $B \propto 1/r$, so if the distance becomes twice its original value, the magnitude of B becomes half. Therefore, the correct answer is (b).

9. Magnetic field at a point near a long current-carrying conductor is 2×10^{-5} T. What will be the value of magnetic field if current flowing is tripled?

- (a) 0.67×10^{-5} T (b) 2×10^{-5} T

- (c) 4×10^{-5} T (d) 6×10^{-5} T

Ans. We know that $B \propto I$, so if the current flowing through the conductor is tripled, the magnitude of B will also be tripled. Therefore, the correct answer is (d).

10. How does the magnitude of current through a short circuit compare with the normal current flowing in the circuit when there is no shorting?

- (a) Current through the short circuit is very high
(b) Current through the short circuit is very low
(c) Current through the short circuit is the same as in the normal circuit
(d) Current through the short circuit is zero

Ans. The correct answer is (a).

Value-based Questions

(Optional) (Page 114)

1. Ramesh's father is a scrap dealer. He works hard the whole day to manually separate iron particles from the scrap. Ramesh advised his father to use an electromagnet to do the same work.

- (a) Why did Ramesh advise his father to use an electromagnet?
(b) What values are associated with Ramesh's advice?

Ans. (a) An electromagnet makes it easy to find and move metallic objects. When the electricity is on, it works like a magnet, separating metallic objects from other scrap, and drops the object when electricity is switched off.

- (b) Concern and love for parents; practical application of concepts learnt in classroom

2. Monika was ironing her school uniform like every other day. She accidentally touched the electric iron and got an electric shock. She switched off the iron and took out the plug. On opening the plug, she found that the wire with green insulation was out of its socket. She fixed the wire in the socket and connected the electric iron to the mains through the plug.

- (a) Name the wire with green insulation.
(b) How does it help in avoiding electric shock?
(c) What values do we learn from Monika?

Ans. (a) Earth wire

- (b) It creates a safe route for the current to flow through when the live wire comes in contact with the metallic body of the appliance.

- (c) Doing one's own work; putting classroom concepts to practical use

3. Nishat received a souvenir from his cousin, a metallic kangaroo with a magnet attached to its back. His younger sister, Nikhat, a class V student started playing with it and found that the souvenir got stuck to various metallic objects, like the refrigerator door and the spoon. She took a wrist watch and was about to bring it close to the magnet, when Nishat told her not to do so and patiently explained the reason so she wouldn't repeat it in his absence.

- (a) Why can the watch be damaged if brought near a magnet time and again?
(b) What values do we learn from Nishat?

- Ans.** (a) The balance wheel of a mechanical watch can get magnetised, affecting the performance of the watch.
(b) Being patient and loving with children; using concepts learnt in classroom in real life

Sources of Energy

Checkpoint _____ (Page 117)

- The amount of energy possessed by an object is equivalent to
 - the force applied to it.
 - its mass.
 - the amount of work it can do.
 - its weight.

Ans. The correct answer is (c).

- The energy of atomic particles is measured in electron volt (eV). 1 eV is equal to
 - 1.6×10^{-19} J.
 - 1.6×10^{-9} J.
 - 1.6 J.
 - 1.6×10^9 J.

Ans. The correct answer is (a).

- State the principle of conservation of energy.

Ans. According to the principle of conservation of energy, energy is neither created nor destroyed; it only transforms from one form to another.

- Reservoir A has water stored at a height of h above sea level. Reservoir B has water stored at height $2h$ above sea level. What is the ratio of the gravitational potential energy stored in the water in reservoir A to that in reservoir B?

Ans. Assuming that the amount of water stored in both the reservoirs is the same, with its mass being m , the PE of water in reservoir A = mgh and the PE of water in reservoir B = $mg(2h)$

$$\frac{\text{PE in A}}{\text{PE in B}} = \frac{mgh}{2mgh} = 1 : 2$$

- When a ball is dropped from a height, its potential energy decreases. Why is it said that its mechanical energy remains constant till it reaches the ground?

Ans. The ball's mechanical energy remains constant as it falls because the decrease in potential energy

is accompanied by an increase in kinetic energy. The potential energy gets converted into kinetic energy, with their sum remaining constant.

- Give three examples to justify the statement: The sun is the ultimate source of all types of energy.

Ans. Sun's heat has created fossil fuels; plants use sun's light to produce food; sun's heat causes wind to flow and be used to produce wind energy

- State one instance where chemical energy is transformed into heat energy.

Ans. Respiration, burning of fuels

- What energy transformations take place in the following devices?

- Microphone
- Solar cell
- Magnetic compass

Ans. (a) sound energy to electrical energy
(b) heat energy to electrical energy
(c) magnetic energy to mechanical energy

- What brings a greater change in the kinetic energy of an object – doubling the velocity or increasing the mass by four times?

Ans. Since the kinetic energy of an object is directly proportional to its mass and directly proportional to the square of its velocity, an increase in mass by 4 times or an increase in velocity by 2 times will have the same effect. The kinetic energy will increase by 4 times in both cases.

- Why is the temperature of the water slightly higher at the foot of a waterfall as compared to the temperature at the top?

Ans. This is because some of the mechanical energy of the water gets wasted in generating heat when it strikes the ground.

Milestone 1

(Page 124)

Multiple-Choice Questions

1. CNG is used in cars instead of petrol because it is
- easily available.
 - easy to transport.
 - safe and convenient to use.
 - more economical.

Ans. The correct answer is (c).

2. To work properly, wind-electric generators need wind speeds of at least about
- 1.5 km/h.
 - 15 km/h.
 - 150 km/h.
 - 1500 km/h.

Ans. The correct answer is (b).

3. The site of a hydroelectric plant should be chosen carefully because it
- produces a large amount of CO₂ and CO.
 - produces a large amount of electricity.
 - affects the organisms in the region.
 - is expensive.

Ans. The correct answer is (c).

4. The condition for producing biogas is
- air but not water.
 - water but not air.
 - air and water.
 - neither air nor water.

Ans. The correct answer is (b).

5. Combustion of fossil fuels in an insufficient supply of oxygen produces
- carbon monoxide.
 - carbon dioxide.
 - oxygen.
 - ozone.

Ans. The correct answer is (a).

6. Conversion of harmful gases into harmless gases is done by using
- windmills.
 - scrubber.
 - catalytic converter.
 - generator.

Ans. The correct answer is (c).

Very Short Answer Type Questions

7. What is the use of electrostatic precipitators?

Ans. Electrostatic precipitators are used in thermal power plants for the removal of suspended particulate matter.

8. How are the sources of energy classified on the basis of recycling period?

Ans. Sources of energy are classified into renewable and non-renewable sources on the basis of recycling period.

9. Why is charcoal considered an expensive fuel compared to wood?

Ans. Charcoal is produced through destructive distillation of wood. In this process, about 75% of the wood is converted into volatile products and only 25% gets converted into charcoal.

10. Among fossil fuels, which is the least polluting?

Ans. Natural gas is the least polluting among fossil fuels.

11. What is a turbine?

Ans. A turbine is a device that rotates when steam, water or wind falls on its blades.

Short Answer Type-I Questions

12. Coal is said to be formed from the wood of trees. Why is then coal considered to be a non-renewable source of energy, whereas wood is regarded as a renewable source of energy?

Ans. Coal is considered a non-renewable source of energy because the conversion from wood into coal takes place over hundreds of millions of years. The rate at which human beings use up coal reserves is much faster than the rate at which coal can be formed.

13. The Government of India has taken a number of measures to encourage the use of LPG in households instead of traditional sources of energy like wood. Why is LPG considered a better option than wood for cooking?

Ans. The main reason LPG is considered a better option than wood for cooking is that LPG does cause environmental pollution while wood requires cutting of trees and releases a large amount of smoke. LPG can also do a much larger amount of work per unit mass as compared to wood, i.e. it has a high calorific value.

14. How does combustion of fossil fuels cause an increase in the greenhouse effect and global warming?

Ans. The combustion of fossil fuels produces carbon dioxide, which is released in the atmosphere. Carbon dioxide has the tendency to absorb infrared radiations radiated by the earth, resulting in the warming of the earth's atmosphere. This is called the greenhouse effect. An increase in the greenhouse effect because of excessive presence of carbon dioxide in the air results in an unnatural increase in temperature of the atmosphere, which is called global warming.

15. Name any two poisonous substances released by burning fossil fuels.

Ans. Sulphur dioxide, nitrogen dioxide, carbon monoxide, methane (any two)

Short Answer Type-II Questions

16. Which is a better fuel between A and B? Study the table to give an answer.

Fuel	Calorific value	Ignition temperature	Products obtained on burning
A	75 kJ/g	25 °C	CO ₂ , CO, Ash
B	50 kJ/g	75 °C	CO ₂

Ans. B is a better fuel than A. Even though A has a higher calorific value than B, the use of A has two problems. One, the ignition temperature of A is at room temperature, which makes its storage difficult. Two, A leaves more harmful products after burning than B does. This makes B a better fuel than A.

17. What are the methods of reducing pollution caused by burning of fossil fuels?

Ans. The pollution caused by the burning of fossil fuels can be reduced by the following ways:

- The use of efficient internal combustion engines to prevent incomplete combustion of fuels, which can release harmful gases
- The use of catalytic converters at the source of harmful gases produced by fossil fuel combustion so that harmful gases are converted into harmless ones
- The use of scrubbers and electrostatic precipitators to remove suspended particulate matter.

18. How is a structure like the Taj Mahal at risk because of the increasing use of vehicles and uncontrolled setting up of factories?

Ans. The consumption of fossil fuels in vehicles and factories produces sulphur dioxide. It dissolves in atmospheric water to form sulphuric acid, which falls on the earth along with rain. This rain, known as acid rain, corrodes the marble in structures like the Taj Mahal.

19. What are the traditional uses of wind energy? How has the traditional use of wind energy been modified for our convenience?

Ans. Two traditional uses of wind energy are:

- It was used to propel sailboats to transport humans and goods from one place to another.
- It was harnessed by windmills to do mechanical work like lifting water from a well and grinding food grains.

Just as wind energy was used to move the blades of a windmill, it is now used to rotate the blades of a wind turbine to produce electricity.

Long Answer Type Questions

20. Draw a labelled schematic diagram of a biogas plant. Apart from helping in production of a clean fuel, name two other benefits of setting up biogas plants.

Ans. Refer the figure given on bottom of the page.

Apart from helping in the production of a clean fuel, a biogas plant is also helpful because it creates manure, which can be used in agriculture and it helps in the safe disposal of organic waste.

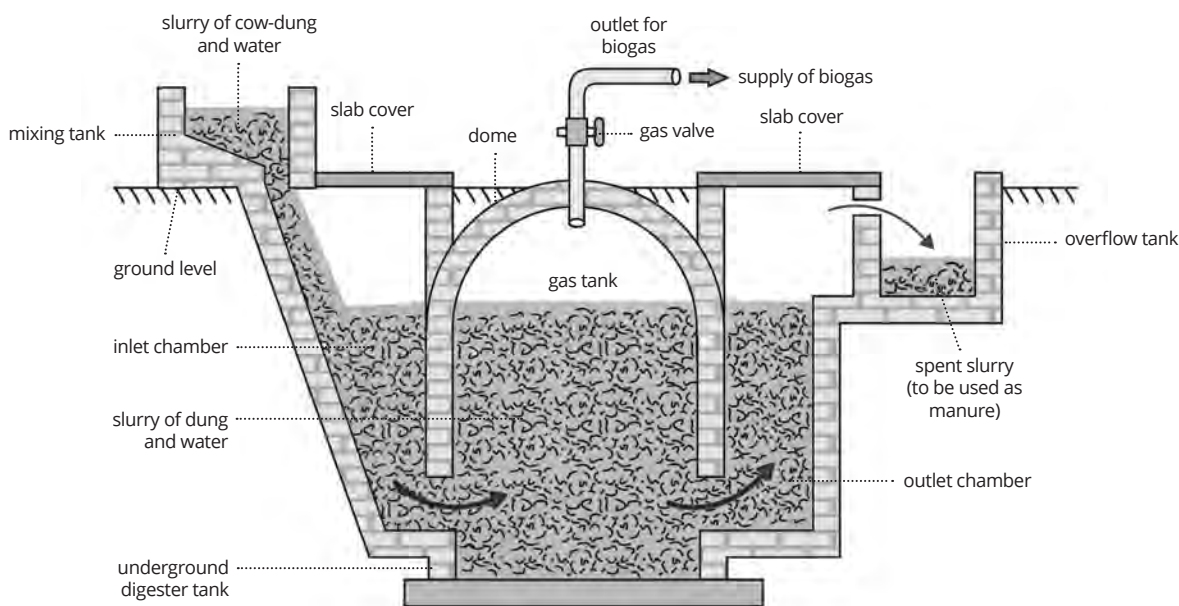

A biogas plant

21. Explain the working of a wind turbine generator.

Ans. A wind turbine generator works in the following manner:

It consists of a wind turbine (a rotator to which large-sized blades are attached), which is fixed at the top of a tall tower. The shaft of the turbine is connected to the armature of an electric generator.

When fast moving wind (speed > 20 km/h) strikes the turbine, the blades start rotating.

The shaft of the turbine also starts rotating, which rotates the armature of the generator, and produces electricity.

22. Explain the energy transformations taking place in a hydroelectric power plant.

Ans.

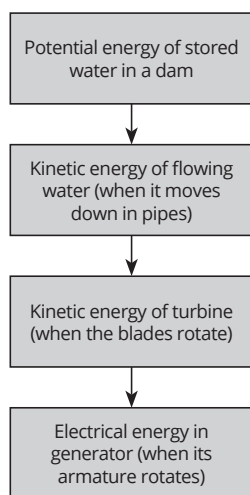

Milestone 2

(Page 133)

Multiple-Choice Questions

1. The efficiency of a modern solar cell is

- (a) 15%. (b) 25%.
(c) 35%. (d) 45%.

Ans. The correct answer is (b).

2. Tidal energy is harnessed by constructing a

- (a) bridge. (b) road.
(c) dam. (d) pipe.

Ans. The correct answer is (c).

3. Ocean thermal energy conversion plants can work only when the minimum temperature difference between water at the surface and water at depths of 2 km is at least

- (a) 10 °C. (b) 20 °C.
(c) 30 °C. (d) 40 °C.

Ans. The correct answer is (b).

4. The destructive purpose of nuclear fission reaction is

- (a) generation of waste products.
(b) atom bomb.
(c) nitrogen bomb.
(d) none of these.

Ans. The correct answer is (b).

5. Geothermal energy is feasible in regions that

- (a) are near the sea.
(b) have abundant supply of coal.
(c) are situated at high altitudes.
(d) are over hot spots in the earth's crust.

Ans. The correct answer is (d).

Very Short Answer Type Questions

6. State one basic difference between nuclear fusion and nuclear fission.

Ans. In nuclear fusion, two lighter nuclei fuse to form a heavier nucleus, while in nuclear fission, a heavy nucleus splits into lighter nuclei.

7. Why is it very expensive to use solar cells?

Ans. It is expensive to use solar cells because of expensive components like special grade silicon and silver.

8. Why can the current produced by solar cell panels not be used directly?

Ans. The current produced by solar cell panels cannot be used directly because the current is produced in DC while most of our appliances run on AC.

9. Name two sources of energy that do not derive their power directly or indirectly from the sun.

Ans. Nuclear energy and geothermal energy

10. State Einstein's mass-energy equivalence relation.

Ans. $E = \Delta mc^2$, where E is energy, Δm is mass defect, and c is the speed of light in vacuum

Short Answer Type-I Questions

11. What type of food can be cooked and what type of food cannot be cooked in a solar cooker?

Ans. Food that requires boiling, steaming, stewing, or dehydrating (rice, pulses, etc.) can be cooked using a solar cooker. Frying or making chapattis, and sometimes baking, are not possible.

12. What is solar constant? What is its value?

Ans. Solar constant is the amount of solar energy received per second by one square metre area at the outer edge of the earth's atmosphere exposed perpendicularly to the rays of the sun at the average distance between the sun and the earth. Its approximate value is 1.4 kW/m².

13. List any two limitations of the energy obtained from oceans.

Ans. Two limitations of the energy obtained from oceans are:

- (i) The devices and technologies needed to extract the energy are very expensive.
- (ii) The amount of power generated is very low.

14. What is meant by environmental consequences of using a particular source of energy?

Ans. The environmental consequences of using a particular source of energy refers to the effect the use of that source of energy has on the environment. These effects are generally negative, e.g. pollution and greenhouse effect because of the use of fossil fuels; damage to the ecosystem of a region because of hydroelectric power plants; radioactive waste being released in the environment because of the use of nuclear energy.

Short Answer Type-II Questions

15. Explain why a solar cooker consists of

- (a) a wooden box with black painted surfaces.
- (b) a glass sheet as a cover.
- (c) a plane mirror as a reflector.

Ans. (a) The wooden box, along with the lining of the insulated material, prevents the loss of heat. The black painted surface absorbs heat better than any other colour so that the temperature of the cooker rises faster.

- (b) The glass sheet covers prevent the infrared radiations from escaping.
- (c) The plane mirror reflector can be adjusted to any angle so that the reflected sunlight falls on the glass sheet cover.

16. Explain why a solar water heater consists of

- (a) metallic box painted black.
- (b) copper tubes bent in the form of a coil.
- (c) a glass sheet as a cover on metallic box.

Ans. (a) The insulated metallic box prevents the loss of heat and its black surface absorbs heat fast to allow a quick rise in temperature.

- (b) The copper tubes are bent to increase the surface area for absorbing heat.
- (c) The glass sheet cover traps the infrared radiations.

17. Briefly discuss three principles based on which electricity can be generated from the ocean.

Ans. The three principles based on which electricity can be generated from the ocean are:

- (i) Tidal energy – The rising water during high tide and the receding water during low tide

are made to fall on a turbine, which produced electricity through a generator.

- (ii) Wave energy – Sea waves are made to move up and down inside a large column, compressing the air inside, which rotates the connected turbine to produce electricity.
- (iii) Ocean thermal energy – When the temperature difference between the water at the surface of the ocean and water at depths of 2 km is high enough, the warm water under the ocean is used to boil a liquid such that its vapours rotate the blades of a connected turbine. This produces electricity through a generator.

18. What are the conditions necessary for generating electricity from a nuclear fission and from a nuclear fusion reaction?

Ans. To generate electricity from nuclear fission, we require enriched radioactive material, control rods to absorb excess neutrons, a moderator to slow down the fast-moving neutrons, and a coolant that transfers heat from the reactor to the water in the heat exchanger. Nuclear fusion is still not used to generate electricity.

Long Answer Type Questions

19. Explain the working of a solar cooker. What are some of its advantages?

Ans. In order to cook food in a solar cooker, the food materials are placed in containers with appropriate amount of water and lids are fixed on them. The containers are placed inside the wooden box painted black from inside and the glass sheet cover of the box is closed. The solar cooker is then placed in the open, turned towards the sun. The angle of the plane mirror reflector is adjusted to allow a large amount of the reflected sunlight to fall on the glass cover. Sun rays passing through the glass cover get absorbed by the black surfaces inside the box, which heats the box up. The reflected infrared radiations, which are of longer wavelength, are not allowed by the glass cover to escape. As more and more radiations get trapped inside the black box, the temperature rises to about 100–140 °C and the heat cooks the food in the containers.

Advantages of solar cooker are:

- (i) It saves fuel.
- (ii) It does not produce smoke or any polluting substance.
- (iii) Food is cooked at a relatively low temperature, so its nutritional value is preserved.
- (iv) It has a very low installation and maintenance cost.

(v) It can cook up to four dishes simultaneously.

20. Explain the working of an ocean thermal energy conversion power plant.

Ans. An ocean thermal energy conversion power plant is operational when the temperature difference between water at the surface of the ocean and water at depths up to 2 km is 20 °C or more. The warm water of the sea is used to boil a liquid like ammonia or chlorofluorocarbon in the evaporator to obtain its vapour. These resulting vapours are used to rotate the turbine blades. The rotating turbine rotates the armature of the generator to generate electricity. The cold water from the ocean is pumped up to the condenser of the power plant to condense ammonia vapour into liquid ammonia. The liquid ammonia is again taken back to the evaporator and the process is repeated again and again.

21. Why are our energy needs much higher as compared to people from a few generations ago?

What are the problems created by this increasing demand of energy? How can we solve them?

Ans. Our energy needs are much higher compared to people from a few generations ago because of the various machines and appliances we use that consume energy. These include our industries, our means of conveyance, our computers, television sets, washing machines, water heaters, etc. The problems caused by increasing demands of energy include rapid depletion of non-renewable sources, resulting in increasing cost of fuel, and environmental consequences like pollution, deforestation, global warming, high amount of radioactive waste, etc.

We can solve these problems by minimizing the wastage of energy and finding ways to use alternate sources of energy.

22. Distinguish between controlled and uncontrolled nuclear reactions.

Ans. Refer to Table given below:

Differences between controlled and uncontrolled chain reactions

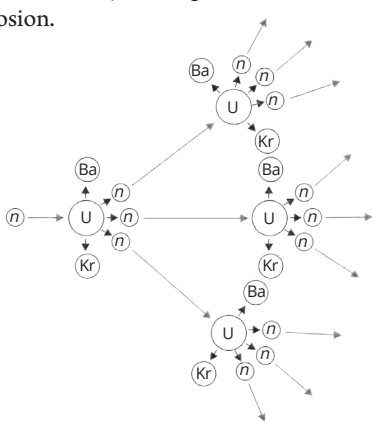
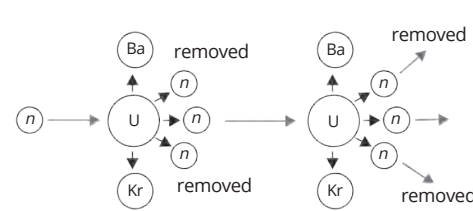
Parameter	Uncontrolled chain reaction	Controlled chain reaction
1. Nature	<p>A chain reaction in which all the neutrons produced during the fission reaction are deliberately allowed to go out of control by causing further fissions leading to an explosion.</p> 	<p>A chain reaction in which the neutrons produced during the fission reaction cause just one fission reaction further and the extra neutrons are removed by control rods.</p> 
2. Rate of reaction	10^{20} uranium-235 atoms undergo fission in just one minute.	Only 60 uranium-235 atoms undergo fission in one minute.
3. Energy released	Energy is produced in unmanageable amount.	Energy is produced at a slow, steady and manageable rate.
4. Usage of energy	Energy released cannot be used for useful purposes.	Energy released can be used for useful purposes like generation of electricity.
5. Purpose	It is used for destructive purpose, i.e. making a nuclear bomb (or atom bomb).	It is used for constructive purposes like generation of electricity.

Higher Order Thinking Skills (HOTS) Questions

(Page 135)

1. You have wood, kerosene and LPG. Which one source of energy would you prefer for cooking food, and why? Give three reasons.

Ans. We shall prefer to use LPG as the source of energy for cooking our food. The reasons are:

- (i) It burns without producing any smoke.
- (ii) It leaves no residue.
- (iii) It is convenient to use and can be stored and handled safely.

[Note that the calorific value of LPG is higher than wood, but very close to kerosene, so it cannot be a valid reason for choosing it above kerosene.]

2. Why is energy from water flowing in a river considered to be an indirect form of solar energy?

Ans. Water from rivers gets evaporated because of sun's energy. This water vapour forms clouds. Clouds cause rain, and this water flows through the rivers. Thus, the energy from the water flowing in a river is indirectly a form of solar energy.

3. How does construction of dams across rivers get linked with the production of greenhouse gases?

Ans. When dams are constructed, a large area of vegetation gets submerged under the water of the dam. This vegetation rots in the submerged areas under anaerobic conditions to produce a large amount of methane, a greenhouse gas.

4. Out of two elements A and B, with mass numbers 2 and 235 respectively, which one is suitable for making (a) a nuclear reactor and (b) a hydrogen bomb? Name the nuclear reaction involved in each case.

Ans. (i) The element B with mass number 235 is suitable for making a nuclear reactor. The reaction involved is a nuclear fission reaction.

(ii) The element A with mass number 2 is suitable for making a hydrogen bomb. The reaction involved is a nuclear fusion reaction.

5. Fly ash from coal-based thermal power plants causes air and soil pollution. Can you suggest some methods for alternate uses of fly ash so as to avoid pollution?

Ans. Fly ash can be used for making bricks and blocks that can be used in buildings, road pavements, etc. Fly ash can also be utilized in the construction of roads. Mixing of fly ash to cement also improves the properties of the cement.

6. Would you consider hydrogen to be a cleaner and more efficient fuel than CNG? If yes, why is it not used in everyday life?

Ans. Yes, hydrogen is a cleaner and more efficient fuel than CNG as its thermal efficiency is higher and its combustion produces water vapour, which does not pollute the atmosphere. However, it is not used as a fuel in everyday life because of its highly explosive nature, which makes its storage and transportation unsafe.

7. How do technological inputs improve the efficiency of biomass fuel?

Ans. Technological inputs improve the efficiency of biomass fuel in the following ways:

- (i) Biomass can be converted into biogas using a biogas plant. Biogas is a more efficient fuel than biomass.
- (ii) Instead of burning biomass in open chulhas, it can be converted into charcoal, which has a much better thermal efficiency than biomass.
- (iii) Biomass fuel can itself be used with higher efficiency using technologically advanced chulhas and furnaces.

8. How can we reconcile the advantages of nuclear energy with its potential for harm?

Ans. The advantages of nuclear energy can be reconciled with its potential for harm through better design and management of nuclear power plants. Some of the possible steps are:

- (i) Do not construct power plants close to areas of high population.
- (ii) Use strong fail-safe mechanisms that ensure the nuclear fuel does not heat up even in case of accidents.
- (iii) Find most suitable ways to dispose the radioactive waste from the nuclear reactors.

Self-Assessment

(Page 135)

Multiple-Choice Questions

1. Which of the following is a renewable source of energy?

- (a) Coal
- (b) Natural gas
- (c) Wood
- (d) Petroleum

Ans. The correct answer is (c).

2. A solar cell is made of

- (a) an insulating material.
- (b) a conducting material.
- (c) a semiconducting material.
- (d) an alloy.

Ans. The correct answer is (c).

3. A major problem in harnessing nuclear energy through nuclear fission is
- sustaining chain reaction.
 - splitting the nucleus.
 - converting nuclear energy to electric energy.
 - disposal of nuclear wastes.

Ans. The correct answer is (d).

4. We have so far not been able to use nuclear fusion to generate electric power because
- it yields a lower amount of energy as compared to fission.
 - it causes pollution.
 - very high temperatures are required to initiate nuclear fusion.
 - the fuel required for fusion is not easily available.

Ans. The correct answer is (c).

Assertion-Reason Type Questions

For question numbers 5 to 14, two statements are given – one labelled Assertion (A) and the other labelled Reason (R). Select the correct answer to these questions from the codes (a), (b), (c) and (d) as given below.

- Both A and R are true and R is the correct explanation of the assertion.
- Both A and R are true but R is not the correct explanation of the assertion.
- A is true but R is false.
- A is false but R is true.

5. **Assertion:** All the potential energy stored in a water reservoir in a dam cannot be converted into electrical energy.
Reason: Energy can neither be created nor destroyed.

Ans. (b)

6. **Assertion:** All conventional sources of energy are non-renewable.
Reason: Non-conventional sources of energy can be non-renewable.

Ans. (d)

7. **Assertion:** Charcoal is a more efficient fuel than wood is.
Reason: The calorific value of charcoal is about 33 kJ/g, while the calorific value of wood is about 17 kJ/g.

Ans. (a)

8. **Assertion:** Vehicle are supposed to use catalytic converters to minimise pollution.
Reason: Suspended particulate matter from vehicles can cause breathing problems in people.

Ans. (b)

9. **Assertion:** Both biomass and hydroelectricity can be used to run large-scale factories.
Reason: Hydroelectricity, generally, requires much greater initial investment than biomass does.

Ans. (d)

10. **Assertion:** Coal is formed from the wood of trees.
Reason: Both coal and wood are non-renewable sources of energy.

Ans. (c)

11. **Assertion:** The cooking container in a solar cooker is painted black from the outside.
Reason: Black absorbs all wavelengths of light and converts them into heat.

Ans. (a)

12. **Assertion:** Both thermal energy and ocean thermal energy make use of coal to produce energy.
Reason: Thermal energy can be polluting, but ocean thermal energy is not.

Ans. (d)

13. **Assertion:** Sun's energy is a result of nuclear fusion of hydrogen nuclei to form helium.
Reason: Controlled nuclear fusion is used to produce a great amount of energy.

Ans. (c)

14. **Assertion:** Nuclear energy is considered a clean energy source.
Reason: The leftover fuel and radioactive by-products from a nuclear power plant can be difficult to dispose.

Ans. (b)

Source-based/Case-based/Passage-based/Integrated Questions

Answer the questions on the basis of your understanding of the following paragraphs and the related studied concepts.

15. Renewable energy sources such as wind energy are vital for the Indian economy, not only from the point of view of supply, but also from the perspective of environmental and social benefits.



India is the world's fifth largest wind-power producer and the largest windmill facilities in India are installed in Tamil Nadu. Muppandal is a small village of Tamil Nadu and one of the most important sites of wind-farm in the state. It uses wind from the Arabian Sea to produce renewable energy. The suitability of Muppandal as a site for wind farms stems from its geographical location as it has access to the seasonal monsoon winds.

The electrical generators used on wind turbines in sites like Muppandal, produce an output AC of 240 V and a frequency of 50 Hz even when the wind speed is fluctuating. A transformer may be required to increase or decrease the voltage so it is compatible with the end usage, distribution or transmission voltage, depending on the type of interconnection. (CBSE SP 2019)

- I. (a) State the principle behind electric generator.
 (b) The output frequency of wind turbine is 50 Hz. What is meant by this statement?
 (c) Why do you think Muppandal is at an advantageous position for this project?
 (d) Based on the data represented in the graph below, which of the two cities A or B would be an ideal location for establishing a wind-farm and why?

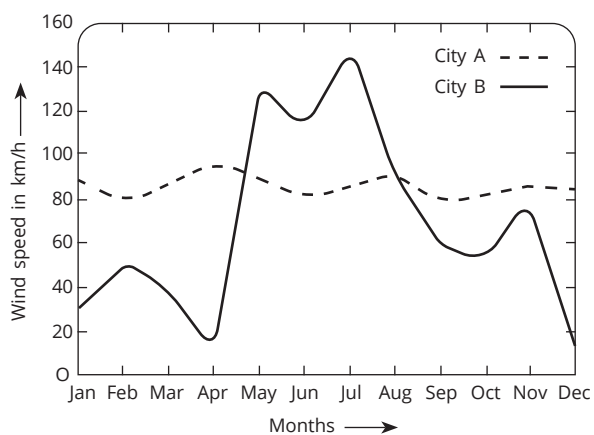

- Ans. (a) The principle behind electric generator is Electromagnetic Induction – the phenomenon of producing current in a coil by changing the magnetic field associated with it.
 (b) The polarity of the output alternating current changes every $1/100$ seconds. Alternately: In 1 second the output (AC) completes 50 cycles.
 (c) The suitability of Muppandal as a site for wind farms stems from its geographical location as it has access to the seasonal monsoon winds.
 (d) City A; It is more suitable for a wind-farm as there is consistently high wind-speed in that city throughout the year.

- II. (a) What type of energy is wind energy?
 (i) Renewable energy
 (ii) Non-renewable energy
 (iii) Conventional energy
 (iv) Commercial energy

Ans. (i) Renewable energy

- (b) What should be the minimum speed of the wind to constantly run a wind turbine generator?
 (i) 20 km/h (ii) 25 km/h
 (iii) 30 km/h (iv) 40 km/h

Ans. (i) 20 km/h

- (c) What is the global rank of India in wind power production?
 (i) First (ii) Third
 (iii) Fifth (iv) Seventh

Ans. (iii) Fifth

- (d) Which device is required to increase or decrease the voltage of a windmill for proper transmission of wind energy?
 (i) Transformer (ii) Galvanometer
 (iii) Motor (iv) Ammeter

Ans. (i) Transformer

- (e) Which country is known as 'the country of winds'?
 (i) Germany (ii) Denmark
 (iii) India (iv) Japan

Ans. (ii) Denmark

16. Nuclear power plants employ nuclear fission chain reaction to heat water, creating steam that drives turbines to generate electricity. Most nuclear reactors use U-235 as the fuel. When a neutron strikes the nucleus of U-235, it causes the nucleus to fission and produce about 83.14 TJ/kg of energy. The nuclear plants at Chernobyl and Fukushima, the sites of the two most severe nuclear disasters, also used U-235 for controlled nuclear fission reactions. In both the disasters, the reason for the release of radioactive material was the failure of the cooling system because of generator failure. In both cases, it has been found



that adequate safety measures could have prevented the disasters and the severe loss of lives and contamination of the surrounding environment.

- I. (a) What is the role of a coolant in a nuclear power plant? What coolants are typically used in nuclear plants?
- (b) For a chain reaction to continue, what is the third product formed on the fission of U-235 along with Ba-141 and Kr-92?
- (c) If $1 \text{ TJ} = 2.3 \times 10^8 \text{ kcal}$ and the calorific value of coal is about 8000 kcal/kg , how many times higher is the energy produced from 1 kg of fuel in U-235 fission compared to 1 kg of fuel in a thermal power plant?
- (d) What component of a nuclear reactor helps slow down the speed of neutrons so that a chain reaction through continued fission becomes possible?

Ans. (a) Coolant transfers the heat produced in the reactor to the water in a heat exchanger to produce steam. Liquid sodium and heavy water are the common coolants used in nuclear plants.

- (b) Neutrons
(c) 2.4×10^6 times
(d) Moderator

- II. (a) The common fuel for a nuclear energy power plant is
- (i) uranium-238.
(ii) uranium-235.
(iii) uranium-234.
(iv) none of the above.

Ans. (ii) uranium-235.

- (b) Fukushima Nuclear Power Plant is located in which country?
- (i) South Korea
(ii) North Korea
(iii) Vietnam
(iv) Japan

Ans. (iv) Japan

- (c) Which of the following is not a coolant used in nuclear plants?
- (i) Liquid sodium (ii) Heavy water
(iii) Cadmium (iv) Helium

Ans. (iii) Cadmium

- (d) Where is the first nuclear power plant in India located at?
- (i) Madras (ii) Kalapakkam
(iii) Tarapur (iv) Narora

Ans. (iii) Tarapur

- (e) The control rods used in a reactor of nuclear power plant are made of
- (i) graphite. (ii) boron.
(iii) sodium (iv) steel.

Ans. (ii) boron.

Very Short Answer Type Questions

17. In a box-type solar cooker, what is the range of temperature that can be achieved in two to three hours?
- Ans.** The range of temperature that can be achieved in a box-type solar cooker in two to three hours is $100\text{--}140 \text{ }^\circ\text{C}$.
18. What is a chain reaction?
- Ans.** A chain reaction is a reaction that continues on its own as one occurrence of the reaction triggers the next occurrence.
19. If 100 J of solar energy is received by the upper atmosphere, how much of it reaches the earth's surface?
- Ans.** The earth's surface absorbs about 47% of the sun's energy reaching the outer atmosphere. Thus, if 100 J is received by the upper atmosphere, the energy reaching the earth's surface = 47% of $100 \text{ J} = 47 \text{ J}$.
20. Name two products obtained by destructive distillation of wood.
- Ans.** Two products obtained by destructive distillation of wood are charcoal and tar.
21. The ignition temperature of fuel A is near room temperature and that of fuel B is above room temperature. Which is a safer fuel to be stored at home?
- Ans.** Fuel B is the safer fuel to be stored at home because the risk of it igniting on its own is lower.
22. Can a solar panel be used as a source of energy in a space probe sent to Uranus or beyond? Why or why not?
- Ans.** No. The sun's heat reaching this far in the solar system is not enough to generate electricity that can be put to a productive use.

Short Answer Type-I Questions

23. State any two characteristics of a good source of energy.
- Ans.** A good source of energy has the following characteristics:
- (a) It is safe and convenient to use.
(b) It can do a large amount of work per unit volume or mass.
(c) It is cheaply available.
(d) It does not cause environmental pollution. (any two)

- 24.** State any two reasons why dry wood is not considered a good domestic fuel.
- Ans.** Dry wood is not considered a good domestic fuel because of the following reasons:
- Its calorific value is very low.
 - Its burning produces a lot of smoke and harmful gases.
- 25.** Give one advantage and one disadvantage of a windmill.
- Ans.** One advantage of a windmill is that it is environment-friendly.
One disadvantage is that it needs a large area to set up.
- 26.** Mention the main use of slurry left behind in a biogas plant. State the nutrients present in the slurry on which this use is based.
- Ans.** The slurry left behind in a biogas plant can be used as manure in agriculture. This is because it is rich in nitrogen and phosphorus compounds.
- 27.** You are given two solar cookers, one with a plane mirror as reflector and the other with a concave mirror as reflector. Which one is more efficient? Give reasons.
- Ans.** The solar cooker with concave mirror reflector is more efficient because the concave mirror can focus the heat radiations on the material kept inside to increase the temperature.
- 28.** What would be your preferred choice for a fuel for cooking food if you live in (a) a metropolitan city, (b) a village, and (c) a forest area?
- Ans.** (a) LPG/LNG
(b) Biomass energy
(c) Wood
- 29.** Mention three ways to reduce the pollution caused by fossil fuels.
- Ans.** The pollution caused by the burning of fossil fuels can be reduced by the following ways:
- The use of efficient internal combustion engines to prevent incomplete combustion of fuels, which can release harmful gases
 - The use of catalytic converters at the source of harmful gases produced by fossil fuel combustion so that harmful gases are converted into harmless ones
 - The use of scrubbers and electrostatic precipitators to remove suspended particulate matter.

Short Answer Type-II Questions

- 30.** Why are solar heating devices painted black? Name two such devices and state two limitations of these.

- Ans.** Solar heating devices are painted black to maximize the absorption of heat energy. Black absorbs heat better than any other colour. Two devices that use this principle are solar cookers and solar water heater. Two limitations of these devices are:
- The devices do not work if it is a cloudy day and sun's radiations are not available.
 - The time taken to reach a high temperature is higher compared to electrical devices.
- 31.** The use of diesel as a fuel for running buses has been banned in Delhi by India's Supreme Court. Give two reasons that could have prompted the Supreme Court to take this decision. Which fuel has replaced diesel in most commercial vehicles in Delhi now? How is it a better fuel?

- Ans.** Two reasons that could have prompted the Supreme Court to ban diesel buses are:
- The combustion of diesel releases many hydrocarbons, which resulted in the high level of pollution in Delhi.
 - Diesel vehicles require more regular maintenance because of the high amount of pollutants released. This makes maintaining a fleet of diesel vehicles very expensive.

CNG has replaced diesel in most commercial vehicles. CNG is a better fuel because it is much cleaner than diesel or petrol and it also brings down the maintenance costs.

- 32.** Explain the functions of the following components:
- Digester in a biogas plant
 - Coolant in a nuclear power plant
 - Wind turbine in a windmill
 - Storage tank in a solar water heater
- Ans.** (a) The digester acts as a storage tank for the slurry and the produced biogas.
(b) The coolant transfers the heat from the nuclear reactor to the water in the heat exchanger to produce steam.
(c) The wind turbine rotates when wind falls on it. The turbine is connected to the armature of the generator through a shaft. When the wind turbine rotates, the generator is rotated to produce electricity.
(d) The storage tank is the part of the solar water heater where hot water is stored as it comes out of the copper tube.

Long Answer Type Questions

- 33.** What causes wind to blow? Name a part of India where wind energy is commercially harnessed. Compare wind power and the power of flowing

water for generating electricity. What are the hindrances in developing them?

Ans. Temperature differences on the earth's surface cause wind to blow. As wind gets warmer over one area, it rises, and cold wind from neighbouring areas flows in. Parts of India where wind energy is commercially harnessed include Gujarat, Maharashtra and Tamil Nadu.

Similarities between wind energy and hydroelectric energy:

- Both are renewable sources of energy.
- Both require large area to set-up.
- Both are pollution free.
- Both are available free of cost.
- Both produce electricity in a form that can be used in unlimited ways.
- Both can be set-up in only some areas where the conditions are suitable.
- Both are expensive to set-up.

Dissimilarities between wind energy and hydroelectric energy:

- Wind energy farms require wind turbines while hydroelectricity requires building of water reservoirs.
- Wind energy farms incur high maintenance cost while the maintenance cost for hydroelectricity is low.
- Wind energy farms require back-up facilities as wind is not available all the time while hydroelectric units do not require extensive back-up facilities.
- Building of a reservoir for hydroelectricity requires the submerging of vast areas while no such large destruction of ecosystem is involved in case of wind energy.

The main hindrances in developing both these energy resources are that they cannot be set-up everywhere; they require large area of land; and they need huge investment initially to set-up.

34. A student constructs a box-type solar cooker. He found that it did not work efficiently. What could this be due to? Give four possible mistakes in the construction and operation of a solar cooker that could have been committed.

Ans. Four possible mistakes that the student could have committed are:

- (i) The box is not lined with insulating material.
- (ii) The box is not painted black from inside.
- (iii) The cover is not made of glass sheet.

(iv) The reflector is not adjusted properly.

35. The waste materials obtained from a market complex are paper scrap, thermocol, vegetable waste, tin cans and glass bottles. Which of these materials can be used for producing biogas? Give four advantages of converting these materials into biogas rather than burning them.

Ans. Out of the given waste materials, paper scrap and vegetable waste can be used to produce biogas. Advantages of converting these into biogas rather than burning them are:

- (i) The thermal efficiency of biogas is much higher so we obtain more energy from the same amount of waste.
- (ii) The production of biogas leaves behind slurry that can be used as manure.
- (iii) The burning of paper or vegetable waste leaves behind residue that needs to be properly disposed.
- (iv) The burning of paper or vegetable waste gives off more smoke than the burning of biogas does.

Let's Compete

(Page 138)

- 1.** The purpose of the glass cover on top of a box-type solar cooker is to
- (a) allow one to see the food being cooked.
 - (b) allow more sunlight into the box.
 - (c) prevent dust from entering the box.
 - (d) reduce heat loss by radiation.

Ans. The correct answer is (d).

- 2.** Electricity from the ocean can be generated based on
- (a) kinetic energy of the waves but not stored thermal energy.
 - (b) stored thermal energy but not kinetic energy of the waves.
 - (c) kinetic energy of the waves as well as stored thermal energy.
 - (d) neither kinetic energy of the waves nor stored thermal energy.

Ans. The correct answer is (c).

- 3.** A device transforming solar energy directly into electricity is called
- (a) a photovoltaic cell.
 - (b) a solar cooker.
 - (c) a thermal battery.
 - (d) none of these.

Ans. The correct answer is (a).

4. The main constituent of charcoal is
- (a) animal waste.
 - (b) coal.
 - (c) wood.
 - (d) water.

Ans. The correct answer is (c).

5. A nuclear reaction in uranium starts when a slow-moving is absorbed by the nucleus of U-235. Which of these is the most appropriate word that fills the blank?
- (a) Proton
 - (b) Electron
 - (c) Atom
 - (d) Neutron

Ans. The correct answer is (d).

6. Which of the following statements is correct regarding tidal energy?
- (a) It is a non-renewable source of energy.
 - (b) It becomes unavailable during continuous dry spells for many years.
 - (c) There are very few suitable sites available for construction of dams to harness it.
 - (d) Tidal power plants require large tracts of valuable land.

Ans. The correct answer is (c).

7. Choose the incorrect statement out of the following:
- (a) Wave energy is a renewable and pollution-free source of energy.
 - (b) Wave power projects do not require a specific site.
 - (c) Wave power is inexpensive.
 - (d) Wave power output is of variable nature.

Ans. The correct answer is (c).

8. Which of these does not have an important use in a typical plant harnessing energy from nuclear fission reactions?
- (a) Water
 - (b) Coal
 - (c) Graphite
 - (d) Uranium

Ans. Uranium is the main fuel, water is the coolant, and graphite is the moderator. The correct answer is (b).

9. Though charcoal is a better fuel than wood or coal, it cannot be used to meet large scale requirements because
- (a) it causes pollution.
 - (b) its calorific value is low.
 - (c) it cannot be stored easily.
 - (d) it is expensive.

Ans. The correct answer is (d).

10. Identify the incorrect statement regarding

geothermal energy.

- (a) It has no potential in India as it can be harnessed only in very cold places.
- (b) It has a lower efficiency as compared to fossil fuels.
- (c) It can be harnessed all through the year.
- (d) It can cause noise pollution.

Ans. The correct answer is (a).

———— Value-based Questions ———— (Optional) (Page 139)

1. Akram had just moved to a new housing society in Mumbai and found that there were three other people in the society who worked in his office. Each of these people drove their own car to the office that was more than 20 km away. Akram convinced them that all four of them should car pool for the office commute.
- (a) What are the benefits of car pooling?
 - (b) What values are shown by Akram in this scenario?

Ans. (a) Car pooling saves fuel, helps reduce pollution and is a cheaper way to commute.
(b) This scenario shows that Akram cares about the environment. He is also not afraid to take the initiative to bring about a positive change and has the ability to convince others to change their ways too.

2. When the demand for electricity rose significantly in a particular coastal region in southern India, the Prime Minister put together a committee of experts and representatives of all stakeholders to carefully evaluate the possibility of setting up a nuclear power plant in the area. Only when the committee gave its approval did the PM let construction begin.
- (a) What are the possible reasons for rise in demand for electricity?
 - (b) What are the benefits and disadvantages of nuclear power plants?
 - (c) What values are displayed by the Prime Minister?

Ans. (a) Possible reasons can include increase in local population, change in economic standards that increases the use of gadgets and appliances, industrial development, and growth in tourism.
(b) Benefits: large amount of energy produced; long-term energy supply; no polluting gases
Disadvantages: expensive installation; high risk of environmental contamination; risk of accidental leakage; limited supply of uranium

- (c) He is conscious of the risks involved when harnessing nuclear energy. He is concerned about the effects it can have on local inhabitants, farmers, industry owners and other stakeholders. He is also prudent enough to spend time in careful evaluation rather than face protests once time and money have been invested into the project.
3. Radha was visiting her ancestral village during her vacations. She noticed that her grandmother still uses wood to cook food and heat water. With the help of her father, she managed to locate a supplier who could deliver charcoal to her grandparents' place regularly and advised her grandmother to replace wood with charcoal.

- (a) Why is charcoal a better fuel than wood?
- (b) What values can we learn from Radha?
- (c) Name one other clean option that is easily available in rural areas even if electricity or LPG is not.

- Ans.**
- (a) Charcoal has a higher calorific value than wood; it does not cause air pollution; it burns with no residue; it is compact, so it is easy to store and transport.
 - (b) Initiative, concern for the elderly and application of concepts learnt in classroom to real life situations
 - (c) Biogas