

## Sample Question Paper Basic (Code 241)

Time Allowed: 3 hours

Maximum Marks: 80

### General Instructions:

1. This Question Paper has 5 Sections A, B, C, D and E.
2. Section A has 20 Multiple-Choice Questions (MCQs) carrying 1 mark each.
3. Section B has 5 Short Answer-I (SA-I) type questions carrying 2 marks each.
4. Section C has 6 Short Answer-II (SA-II) type questions carrying 3 marks each.
5. Section D has 4 Long Answer (LA) type questions carrying 5 marks each.
6. Section E has 3 Case Based integrated units of assessment (4 marks each) with sub-parts of the values of 1, 1 and 2 marks each respectively.
7. All Questions are compulsory. However, an internal choice in 2 Questions of 2 marks, 2 Questions of 3 marks and 2 Questions of 5 marks has been provided. An internal choice has been provided in the 2 marks questions of Section E.
8. Draw neat figures wherever required. Take  $\pi = \frac{22}{7}$  wherever required if not stated.

### Section - A

Section A consists of 20 questions of 1 mark each.

1. For some integer  $p$ , every odd integer is of the form  
(a)  $2p + 1$                       (b)  $2p$                       (c)  $p + 1$                       (d)  $p$
2. If the mode of some data is 7 and their mean is also 7, then their median is  
(a) 10                      (b) 9                      (c) 7                      (d) 8
3. If  $p(x)$  is a polynomial of degree one and  $p(a) = 0$ , then  $a$  is said to be  
(a) value of  $p(x)$ .                      (b) zero of  $p(x)$ .  
(c) constant of  $p(x)$ .                      (d) none of these.
4. The pair of equations  $x = a$  and  $y = b$  graphically represents lines which are  
(a) parallel.                      (b) intersecting at  $(b, a)$ .  
(c) coincident.                      (d) intersecting at  $(a, b)$ .
5. The decimal expansion of the number  $\frac{17}{8}$  will terminate after how many places of decimals?  
(a) 4                      (b) 3                      (c) 2                      (d) Will not terminate
6. The mid-point of a line segment joining two points A(2, 4) and B(-2, -4) is  
(a) (-2, 4).                      (b) (2, -4).                      (c) (0, 0).                      (d) (-2, -4).

7. If in two triangles ABC and PQR,  $\frac{AB}{QR} = \frac{BC}{PR} = \frac{CA}{PQ}$ , then
- (a)  $\Delta PQR \sim \Delta CAB$ . (b)  $\Delta PQR \sim \Delta ABC$ .  
 (c)  $\Delta CBA \sim \Delta PQR$ . (d)  $\Delta BCA \sim \Delta PQR$ .

8. If TP and TQ are the two tangents to a circle with centre O so that  $\angle POQ = 110^\circ$ , then  $\angle PTQ$  is equal to

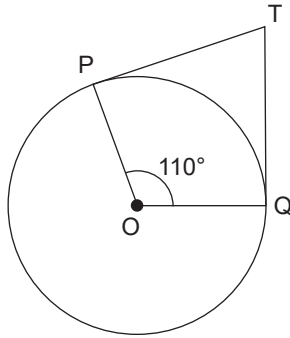

- (a)  $60^\circ$  (b)  $70^\circ$  (c)  $80^\circ$  (d)  $90^\circ$
9. The value of  $(\sin 45^\circ + \cos 45^\circ)$  is
- (a)  $\frac{1}{\sqrt{2}}$  (b)  $\sqrt{2}$  (c)  $\frac{\sqrt{3}}{2}$  (d) 1
10. If  $\Delta ABC$  is right-angled at C, then the value of  $\cos(A + B)$  is
- (a)  $\frac{\sqrt{3}}{2}$  (b) 1 (c)  $\frac{1}{2}$  (d) 0
11. Tangents from an external point to a circle are
- (a) equal. (b) not equal.  
 (c) parallel. (d) perpendicular.
12. The distance between the points (0, 5) and (-5, 0) is
- (a) 5 units. (b)  $5\sqrt{2}$  units. (c)  $2\sqrt{5}$  units. (d) 10 units.
13. The area of the square that can be inscribed in a circle of radius 8 cm is
- (a)  $256 \text{ cm}^2$  (b)  $128 \text{ cm}^2$  (c)  $642 \text{ cm}^2$  (d)  $64 \text{ cm}^2$
14. If  $x \tan 45^\circ \sin 30^\circ = \cos 30^\circ \tan 30^\circ$ , then x is equal to
- (a)  $\sqrt{3}$  (b)  $\frac{1}{2}$  (c)  $\frac{1}{\sqrt{2}}$  (d) 1
15. Two identical solid cubes of side a are joined end to end. Then the total surface area of the resulting cuboid is
- (a)  $12 a^2$  (b)  $8 a^2$  (c)  $10 a^2$  (d)  $11 a^2$
16. If arithmetic mean of a, a + 3, a + 6, a + 9 and a + 12 is 10, then a is equal to
- (a) 1 (b) 2 (c) 3 (d) 4

17. Consider the following frequency distribution:

Class	0 – 5	6 – 11	12 – 17	18 – 23	24 – 29
Frequency	13	10	115	8	11

The upper limit of the median class is

- (a) 17.5                      (b) 17                      (c) 18                      (d) 18.5

18. The probability that a non-leap year selected at random will contain 53 Sundays is

- (a)  $\frac{1}{7}$                       (b)  $\frac{2}{7}$                       (c)  $\frac{3}{7}$                       (d)  $\frac{5}{7}$

**Direction for Questions 19 and 20:** In question numbers 19 and 20, a statement of Assertion (A) is followed by a statement of Reason (R). Choose the correct option.

19. **Assertion (A):** In a circle of radius 6 cm, the angle of a sector is  $60^\circ$ . Then the area of the sector is  $\frac{132}{7}$  cm<sup>2</sup>.

**Reason (R):** Area of the circle with radius  $r$  is  $\pi r^2$ .

- (a) Both Assertion (A) and Reason (R) are true and Reason (R) is the correct explanation of Assertion (A).  
(b) Both Assertion (A) and Reason (R) are true but Reason (R) is not the correct explanation of Assertion (A).  
(c) Assertion (A) is true but Reason (R) is false.  
(d) Assertion (A) is false but Reason (R) is true.

20. **Assertion:** For any two positive integers  $p$  and  $q$ ,  
 $\text{HCF}(p, q) \times \text{LCM}(p, q) = p \times q$ .

**Reason:** If the HCF of two numbers is 5 and their product is 150, then their LCM is 40.

- (a) Both Assertion (A) and Reason (R) are true and Reason (R) is the correct explanation of Assertion (A).  
(b) Both Assertion (A) and Reason (R) are true but Reason (R) is not the correct explanation of Assertion (A).  
(c) Assertion (A) is true but Reason (R) is false.  
(d) Assertion (A) is false but Reason (R) is true.

### Section - B

Section B consists of 5 questions of 2 marks each.

21. For which value of  $p$  does the pair of equations given below has a unique solution?

$$4x + py + 8 = 0$$

$$2x + 2y + 2 = 0$$

22. E is a point on the side AD produced of a parallelogram ABCD and BE intersects CD at F. Show that  $\triangle ABE \sim \triangle CFB$ .

or

In the figure given below,  $OA \times OB = OC \times OD$ . Show that  $\angle A = \angle C$  and  $\angle B = \angle D$ .

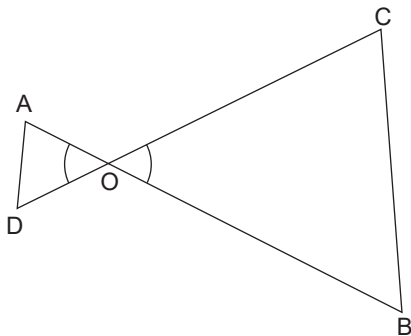

23. Calculate the length of the chord which is at a distance of 6 cm from the centre of a circle of diameter 20 cm.
24. Given A is an acute angle and  $13 \sin A = 5$ , evaluate  $\frac{5 \sin A - 2 \cos A}{\tan A}$ .
25. The circumference of a circle is 22 cm. Calculate the area of its quadrant (in  $\text{cm}^2$ ).

or

Area of a sector of a circle of radius 14 cm is  $154 \text{ cm}^2$ . Find the length of the corresponding arc of the sector. [Use  $\pi = \frac{22}{7}$ ]

### Section - C

Section C consists of 6 questions of 3 marks each.

26. Prove that  $\sqrt{3} + \sqrt{5}$  is an irrational number.
27. Find the roots of the equation  $x^2 + x - (a + 2)(a + 1) = 0$ .
28. The ratio of income of two persons is 9 : 7 and the ratio of their expenditures is 4 : 3. If each of them manages to save ₹ 2000 per month, find their monthly incomes.

or

The sum of the digits of a two-digit number is 5. The digit obtained by increasing the digit at ten's place by unity is one-eighth of the number. Find the number.

29. In the given figure, quadrilateral ABCD is circumscribed and  $AD \perp DC$ . Find  $x$  if radius of incircle is 10 cm.

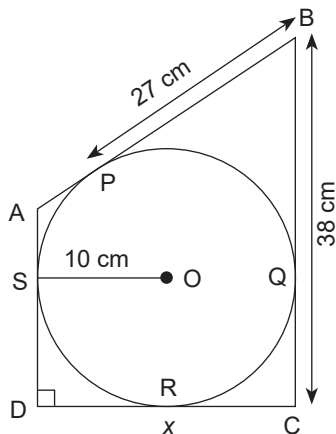

30. Prove:  $\sqrt{\frac{\sec A - 1}{\sec A + 1}} + \sqrt{\frac{\sec A + 1}{\sec A - 1}} = 2 \operatorname{cosec} A$

or

If  $\tan^4 \theta + \tan^2 \theta = 1$ , prove that  $\cos^4 \theta + \cos^2 \theta = 1$ .

31. A bag contains 5 black, 7 red and 3 white balls. A ball is drawn at random from the bag. Find the probability that the ball drawn is
- red.
  - black or white.
  - not black.

### Section - D

Section D consists of 4 questions of 5 marks each.

32. The sum of the areas of two squares is  $640 \text{ m}^2$ . If the difference in their perimeters is 64 m, find the sides of the two squares.

or

Sonal can row a boat at a speed of 5 km/h. If it takes her 1 hour more to row the boat 5.25 km upstream than to return downstream, find the speed of the stream.

33. In the given figure,  $DE \parallel BC$ .
- If  $AD = x$ ,  $DB = x - 2$ ,  $AE = x + 2$  and  $EC = x - 1$ , find the value of  $x$ .
  - If  $DB = x - 3$ ,  $AB = 2x$ ,  $EC = x - 2$  and  $AC = 2x + 3$ , find the value of  $x$ .

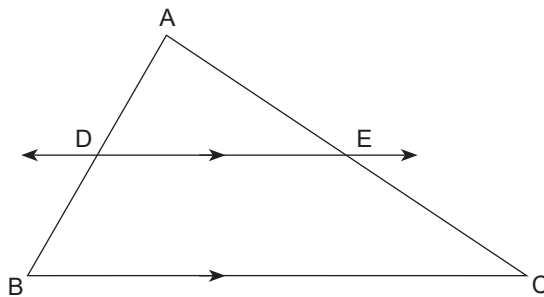

34. A solid cylinder of silver 9 cm high and 4 cm in diameter is melted and recast into a right-circular cone of diameter 6 cm. Find the height and the total surface area of the cone. Give your answer correct to one decimal place. (Take  $\pi = 3.14$ )

or

A sphere of diameter 12 cm is dropped in a right-circular cylindrical vessel, partly filled with water. If the sphere is completely submerged in water, the water level in the cylindrical vessel rises by  $\frac{32}{9}$  cm. Find the diameter of the cylindrical vessel.

35. A study of yield of 150 tomato plants resulted in the following records:

Tomatoes per plant	1 – 5	6 – 10	11 – 15	16 – 20	21 – 25
Number of plants	20	50	46	22	12

Calculate the mean of the number of tomatoes per plant.

### Section - E

Case study based questions are **compulsory**.

36. India is a competitive manufacturing location due to the low cost of manpower and strong technical and engineering capabilities contributing to higher quality production runs. The production of TV sets in a factory increases uniformly by a fixed number every year. It produced 16000 sets in the 6th year and 22600 in the 9th year.



Based on the above information, answer the following questions:

- (a) Find the production during first year. 1 mark
- (b) Find the production during 8th year. 1 mark
- (c) Find the production during first 3 years. 2 marks

**or**

In which year, the production is 29,200 sets.

37. Students of class X are having their Sports Day on a rectangular shaped playground. 12 lines are drawn along the length and along the breadth of the rectangular shaped playground, 200 potatoes are kept at a distance of 1 m from each other. A student, Raju has been told to post a yellow flag on 5th line at distance of  $\frac{1}{10}$  th of the breadth of the playground. Sanju has posted a blue flag on the 11th line at a distance of  $\frac{1}{8}$  th of the breadth. At last, Anushka has posted her green flag exactly halfway between the line segment joining two flags.

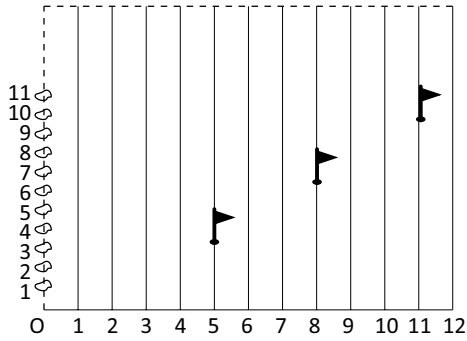

Based on the given situation, answer the following questions.

- (a) What are the coordinates of the spot where Raju has posted his yellow flag? 1 mark
- (b) Where has the green flag been posted? 1 mark
- (c) Find the distance between blue flag and yellow flag? 2 marks

or

What is the distance between yellow flag and green flag?

38. Anita, a student of class 10th, has to make a project on 'Introduction to Trigonometry'. She decides to make a birdhouse which is triangular in shape. She uses cardboard to make the birdhouse as shown in the figure. Considering the front side of birdhouse as right triangle PQR, right-angled at R, answer the following questions.

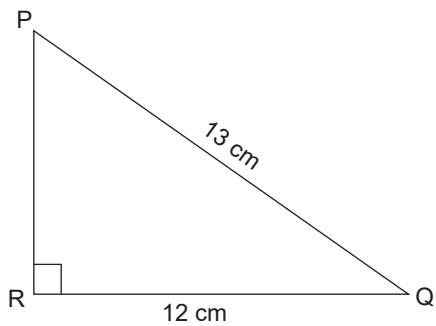

- (a) If  $\angle PQR = \theta$ , then find  $\cos \theta$ . 1 mark
- (b) Find the value of  $\sec \theta$ . 1 mark
- (c) Find the value of  $\frac{\tan \theta}{1 + \tan^2 \theta}$ . 2 marks

or

Find the value of  $\cot^2 \theta - \operatorname{cosec}^2 \theta$ .