



# Ratna Sagar

RATNA SAGAR

PRIMUS

BYWORD

E-LIVE

**Education, Our Mission**



# ICSE

# Living Science

# Physics

**Class 10**

**Chapter-10 Electromagnetism**



As per the latest ICSE syllabus

10



# Living Science PHYSICS



Dhiren M Doshi

Ratna Sagar

EDUCATION, OUR MISSION



## **LEARNING OBJECTIVES**

### **Magnetic Effect of Current**

- ❖ Properties of magnetic field lines around the straight conductor
- ❖ Rules for determining the direction of magnetic field

### **Magnetic Field due to Current in a Loop Or Circular Coil**

- ❖ Properties of magnetic field lines due to current in a loop or circular coil
- ❖ Poles of the loop (or circular coil)

### **Magnetic Field due to a Solenoid**

- ❖ Properties of the magnetic field produced by a current-carrying solenoid
- ❖ Similarities and differences between a current-carrying solenoid and a bar magnet

### **Electromagnet**

❖ Properties of an electromagnet

❖ Uses of an electromagnet

### **Force on a Current –Carrying Conductor Placed in a Magnetic Field**

- ❖ Fleming's left hand rule
- ❖ Magnitude of force acting on a current-carrying conductor placed in a magnetic field

### **Electric Motor**

### **Faraday's Laws of Electromagnetic Induction**

### **AC Generator**

### **Direct Current and Alternating Current**

### **Transformer**



## Magnetic Effect of Current

The magnetic effect of current was discovered by a Danish physicist, **Hans Oersted** in 1820. He performed a simple experiment in which he found that a wire carrying a current was able to deflect a compass needle. He concluded that a current flowing in a wire gives rise to a magnetic field around it. In other words, **flow of electric current in a conductor is the source of magnetic field.**

### Properties of magnetic field lines around the straight conductor

1. The magnetic field lines are in the form of concentric circles around the straight conducting wire.
2. The plane of the magnetic field lines is perpendicular or normal to the straight conductor
3. If the direction of the current in the wire is reversed, the direction of the magnetic field lines is also reversed.
4. The strength of the magnetic field ( $B$ ) is directly proportional to the current ( $I$ ) passing through the conductor, i.e.  $B \propto I$ .
5. the strength of the magnetic field ( $B$ ) is inversely proportional to the distance ( $r$ ) from the conductor, i.e.  $B \propto 1/r$

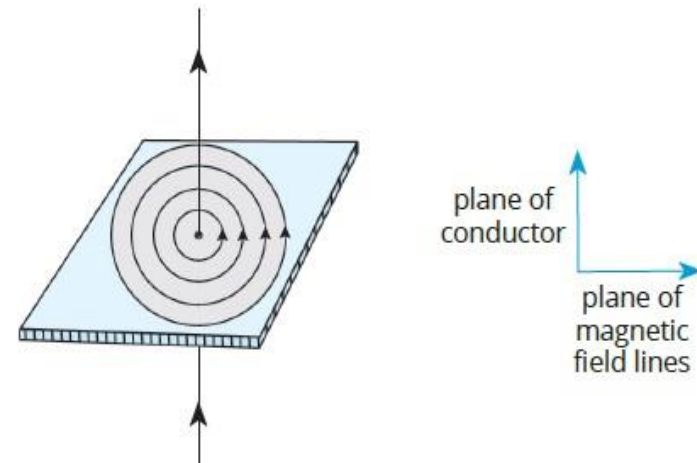



## Rules for determining the direction of magnetic field

The direction of magnetic field around the current-carrying conductor can be determined by the following rules:

**1. Right-hand thumb rule:** If a current-carrying conductor is imagined to be held in the right hand such that the thumb points in the direction of current, then the tips of the fingers encircling the conductor will give the direction of the magnetic field lines.

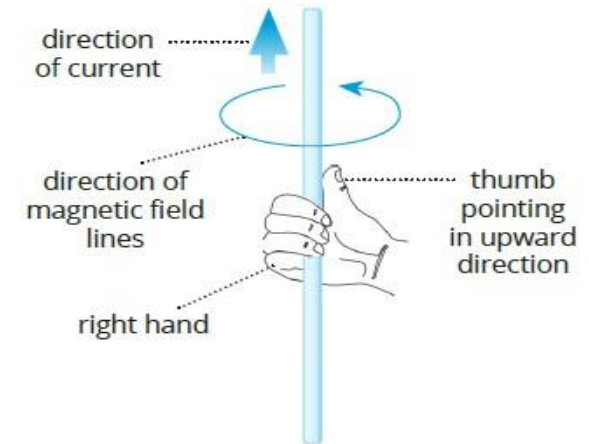

**2. Maxwell's corkscrew rule:** If the forward motion of an imaginary right-handed corkscrew is in the direction of the current through a straight conductor, then the direction of rotation of the thumb gives the direction of the magnetic field lines around the conductor.

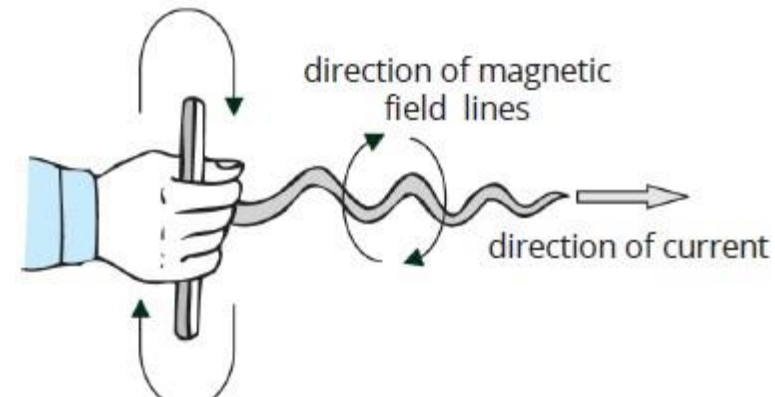



**3. Ampere's swimming rule:** Imagine a man who swims along the conductor in the direction of current facing the needle such that the current enters his feet, then north of the needle deflects towards his left hand.

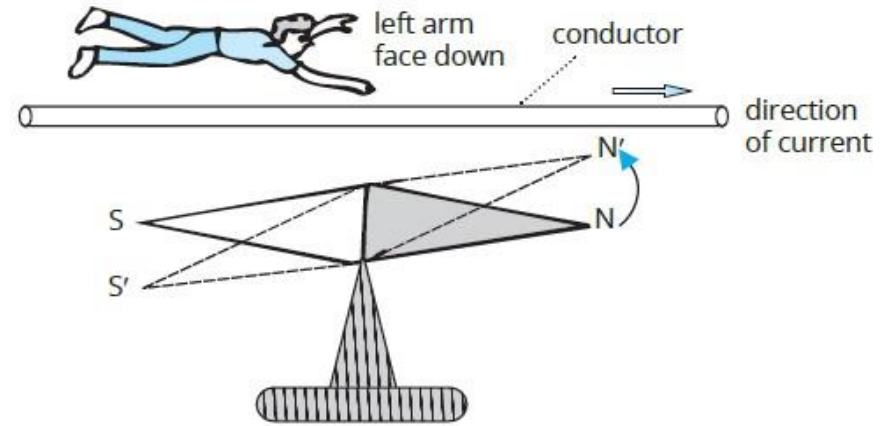

## **Magnetic Field Due to Current in a Loop or Circular Coil**

When current is passed through a circular loop of wire, a magnetic field is produced around it. Near the loop, the magnetic field lines are circular. The concentric circles representing magnetic field lines become bigger as we move away from the loop. At the centre of the loop, the magnetic field lines are straight. **Refer to Experiment -3 Fig 10.7**

## **Properties of magnetic field lines due to current in a loop or circular coil**

1. The magnetic field lines are nearly circular near the wire.
2. The magnetic field lines are in the same direction.
3. At the centre of the loop, the plane of magnetic field lines is perpendicular to the plane of the circular coil.



4. The strength of the magnetic field ( $B$ ) produced by a current-carrying loop increases

- if the strength of the current ( $I$ ) in the loop is increased, i.e.  $B \propto I$ .
- if the number of turns ( $n$ ) in the loop is increased, i.e.  $B \propto n$ .

5. The magnetic field ( $B$ ) increases if the radius of the loop is decreased, i.e.  $B \propto 1/r$ .

## Poles of the loop (or circular coil)

According to the Clock rule:

1. If the current at a face facing us is in **clockwise direction**, that face of the loop behaves like **south pole**.
2. If the current at a face facing us is in **anticlockwise direction**, that face of the loop behaves like **north pole**

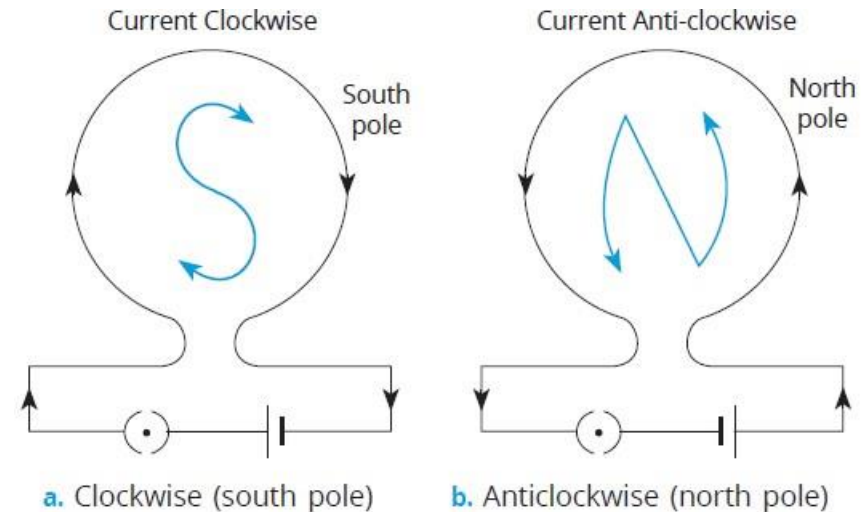

## Magnetic Field Due to a Solenoid

A coil of insulated wire wound around a non-conducting hollow cylindrical tube (like iron rod), whose diameter is less in comparison to its length is called a solenoid. When current is passed through a solenoid, it behaves like a magnet and develops a magnetic field around it.





## Properties of the magnetic field produced by a current-carrying solenoid

1. A solenoid carrying current behaves like a bar magnet as its two ends act as the two poles of a magnet.
2. The magnetic field is uniform inside the solenoid.
3. The intensity of magnetic field of a current-carrying solenoid depends upon the following factors:
  - a. Number of turns in the coil
  - b. Strength of the current
  - c. Nature of the core material:

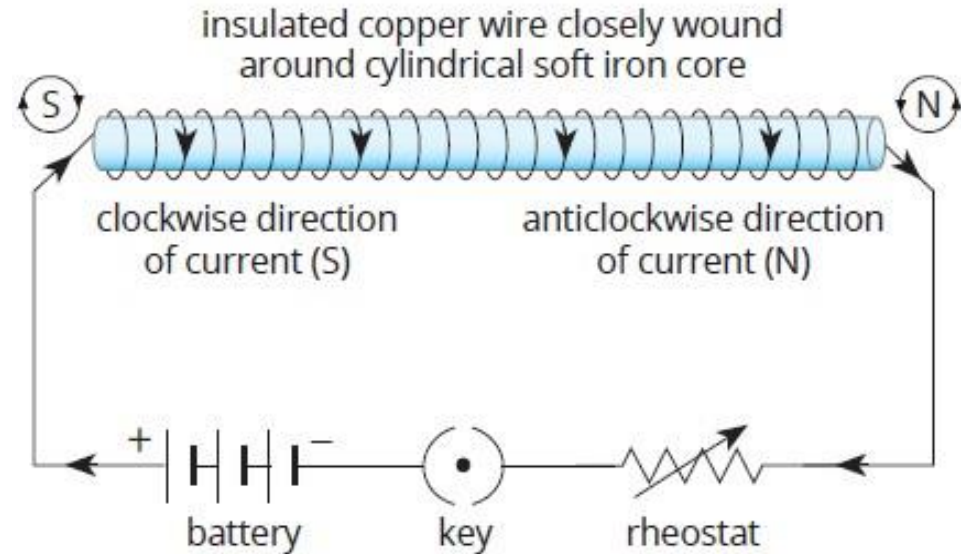

A solenoid

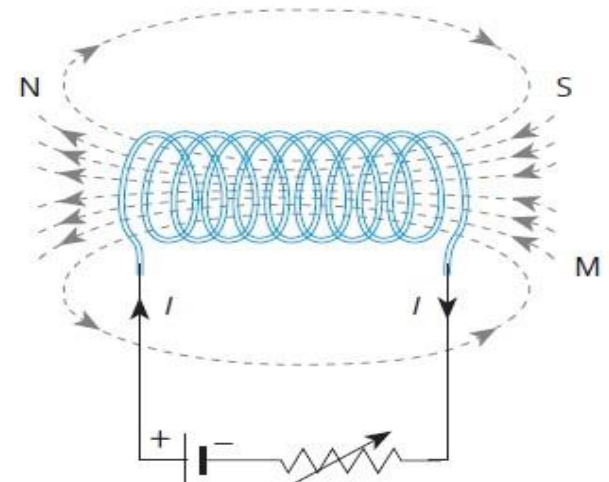

Magnetic field inside the solenoid



## Similarities and differences between a current-carrying solenoid and a bar magnet

### Similarities

The magnetic field lines due to a current-carrying solenoid are identical to the magnetic field lines due to a bar magnet. Thus, a current carrying solenoid behaves like a bar magnet.

### Differences

1. The strength of magnetic field due to a current-carrying solenoid can be increased or decreased by increasing or decreasing the magnitude of current through it. The strength of magnetic field due to a bar magnet cannot be changed.
2. The direction of magnetic field due to current-carrying solenoid can be reversed by reversing the direction of current through it. The direction of magnetic field of a bar magnet cannot be reversed.

### Electromagnet

An electromagnet is a solenoid with a soft iron core. The iron core of the solenoid produces magnetic field as iron gets magnetized due to magnetic induction



## Methods of increasing the magnetic field of an electromagnet

The magnetic field of an electromagnet can be increased in the following two ways:

1. by increasing the number of turns of the solenoid.
2. by increasing the strength of the current through the solenoid.

## Properties of an electromagnet

1. An electromagnet gets demagnetized as soon as the current is switched off.
2. The strength of the magnetic field of an electromagnet can be easily changed by changing the strength of the current in the coil or the number of turns in the solenoid.
3. The polarity of an electromagnet can be changed by reversing the direction of current in the solenoid.

## Uses of electromagnets

1. Electromagnets are used in the construction of a large number of electrical devices like electric bells, loudspeakers, electric motors, electric fans and telephone instruments.
2. Electromagnets are used to lift and transport heavy loads like big machines, steel girders and scrap iron objects for loading and unloading purposes. Unloading of goods is done by switching off the current in the electromagnet.



3. Electromagnets are used to separate magnetic substances like iron and steel from the non-magnetic heap of metal scrap.
4. They are used for removing pieces of iron accidentally getting into wounds or removing steel splinter from the eye.
5. Electromagnets are used for magnetizing steel bars.

### **Force on a Current-carrying Conductor Placed in a Magnetic Field**

H A Lorentz found that a force is experienced by a moving charge in the electromagnetic field. The total force experienced by a moving charged particle when both electric and magnetic fields are present is called **Lorentz force**. A magnetic field produced by a magnet exerts a force on a current-carrying conductor and produces a motion in it.

### **Fleming's left hand rule**

When a current-carrying wire (conductor) is placed in a magnetic field, a force is exerted on the conductor which makes the conductor move. Fleming's left hand rule is used to find out the direction of motion of a current-carrying conductor when placed in a magnetic field. According to Fleming's left hand rule: Stretch the forefinger, central finger and the thumb of your left hand mutually perpendicular to each other. If the forefinger indicates the direction of magnetic field and the central finger indicates the direction of current, then the thumb gives the direction of the force acting on the conductor.

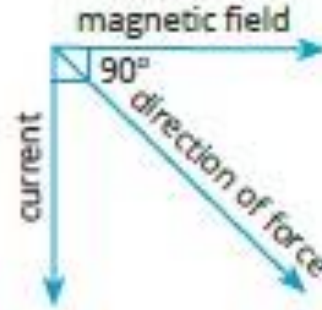

## Magnitude of force acting on a current-carrying conductor placed in a magnetic field

1. The force ( $F$ ) is directly proportional to the current ( $I$ ) flowing in the conductor, i.e.  $F \propto I$ .
  2. The force ( $F$ ) is directly proportional to the strength of the magnetic field ( $B$ ), i.e.  $F \propto B$ .
  3. The force ( $F$ ) is directly proportional to the length of the conductor ( $l$ ), i.e.  $F \propto l$ .
  4. The force ( $F$ ) is directly proportional to the sine of the angle between the direction of current in the wire and the direction of magnetic field, i.e.  $F \propto \sin \theta$
- Combining these, we obtain  $F \propto IBl \sin \theta$   
or  $F = KIBl \sin \theta$  where  $K$  is a constant.



## Electric Motor

An electric motor is a device which converts electrical energy into mechanical energy (kinetic energy).

An electric motor is based upon the magnetic effect of current. When an electric current is passed through a conductor placed at right angle to a magnetic field, a force perpendicular to both the magnetic field and the current acts on the conductor. This makes the conductor move. The direction of motion of the conductor is given by Fleming's left hand rule.

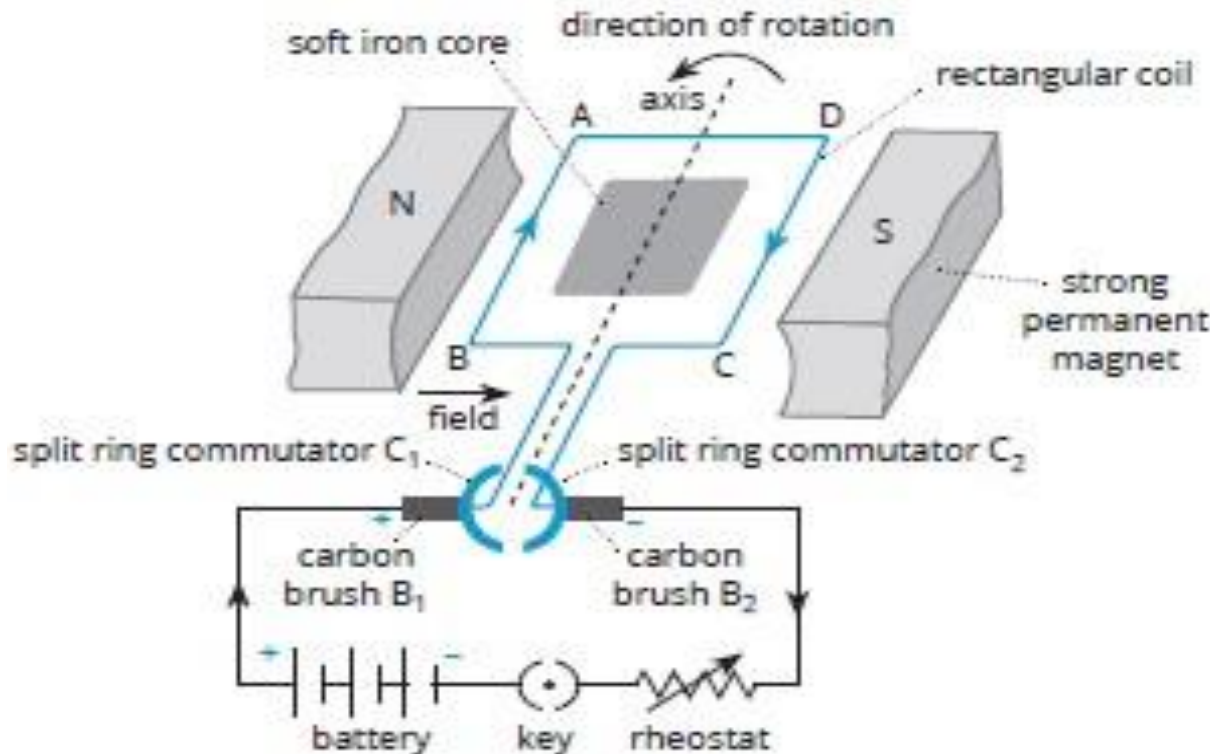

Parts of a DC motor



## Uses of a DC motor

1. DC motors are used to run machinery in factories.
2. DC motors are used in transport (electric locomotives, trolley-buses, etc.).
3. DC motors are used as special motors to carry out heavy work like that of a motor pump to pump out oil from oil well.

## Electromagnetic Induction

In 1831, Michael Faraday, the famous English scientist, performed various experiments and showed that an electric current could be produced in a circuit by changing magnetic field. He called this phenomenon as **electromagnetic induction**. The current so produced in the conductor is called the **induced current**. The electromotive force (or voltage) so produced is called the **induced e.m.f.** Most of the electrical devices (e.g. electric generator, transformer, etc.) are based on this principle.

## Faraday's Laws of Electromagnetic Induction

**First law:** When the magnetic flux linked with a conductor or coil changes, an e.m.f. is induced in it. The induced e.m.f. lasts so long as the change in the magnetic flux linked with the coil continues.

**Second law:** The magnitude of the e.m.f. induced in a conductor or coil is directly proportional to the rate of change of magnetic flux linked with the coil”,



i.e. Induced e.m.f.  $\propto$  Change in magnetic flux / Time in which magnetic flux changes

From the above relation, we can say that the magnitude of induced e.m.f. depends on the following two factors:

- 1. Change in magnetic flux:** The magnitude of induced e.m.f. increases when the change in the magnetic flux is more.
- 2. Time in which the magnetic flux changes:** The magnitude of induced e.m.f. increases when the change in the magnetic flux is rapid.

### Direction of induced e.m.f. and current

The direction of induced e.m.f. and hence the direction of induced current (if the circuit is closed) can be determined by any of the following methods:

**Fleming's right-hand rule:** According to this rule: Stretch out the forefinger, central finger and thumb of your right hand so that they are at right angles to one another (Fig. 10.22a). If the forefinger points in the direction of magnetic field, thumb in the direction of motion of the conductor, then the central finger will point in the direction of the **induced current**.

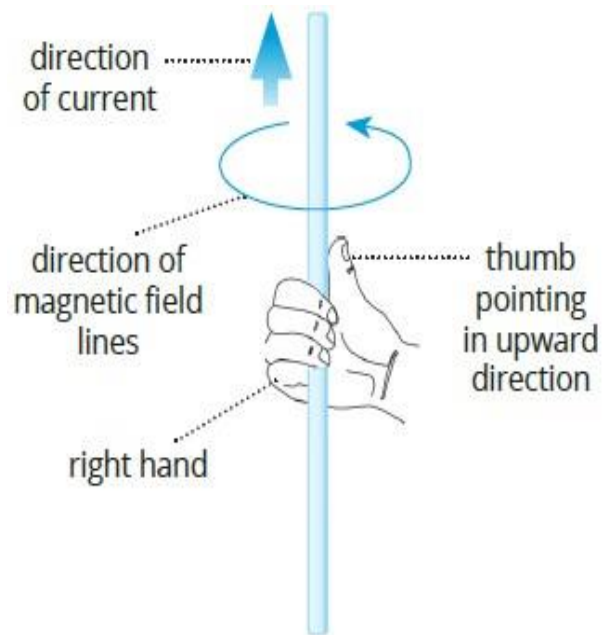





**Lenz's rule:** It states that "The direction of induced e.m.f. (or induced current) is such that it always tends to oppose the cause that is responsible for its existence."

## AC Generator or Alternator

A machine that produces electricity by converting mechanical energy into electrical energy is known as AC generator (also known as alternator). Earlier this was known as dynamo.

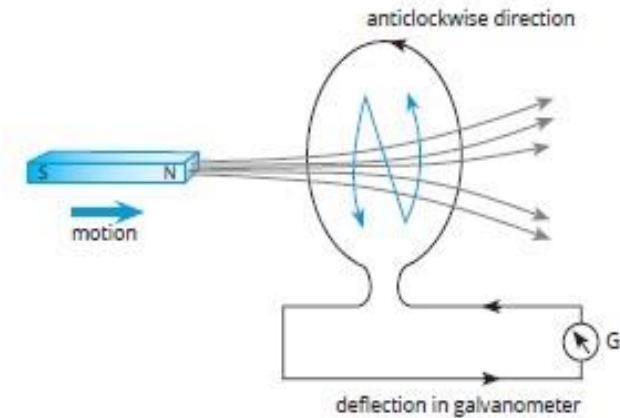
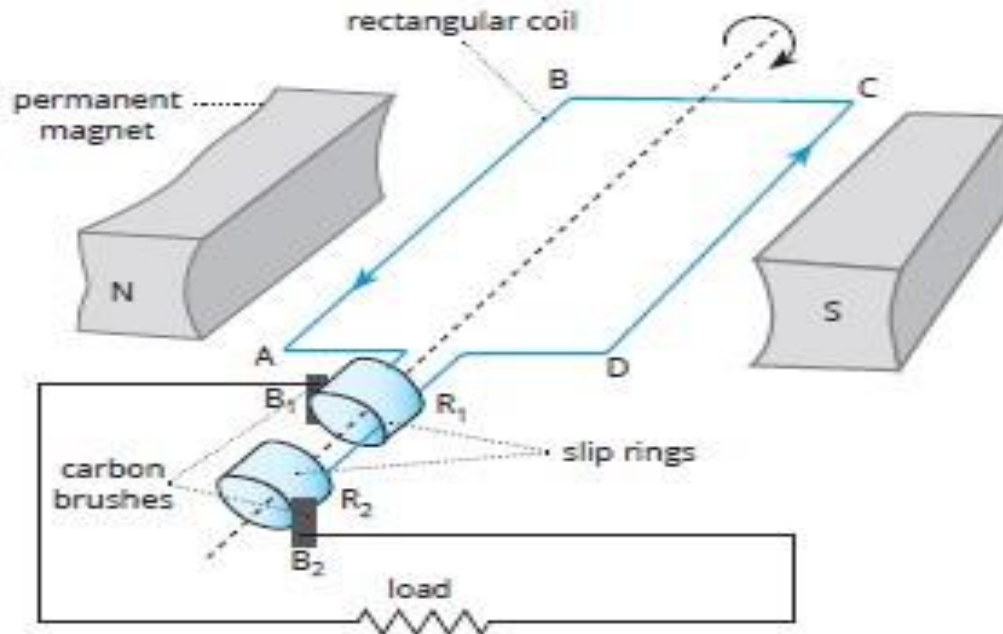

a. N-pole of the magnet moves towards the coil

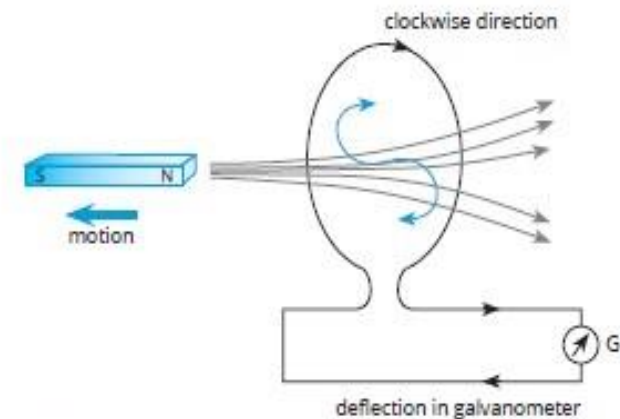

b. N-pole of the magnet moves away from the coil

Lenz's rule



**Principle:** It works on the principle of electromagnetic induction, i.e. when a coil is rotated in a uniform magnetic field, an e.m.f. is induced between the ends of the coil.

The current which changes its polarity after regular intervals of time is called **alternating current (AC)**. This electric generator produces alternating current .

### Frequency of alternating current

In India, the frequency of the alternating current supplied by the power generation units is 50 cycles per second (i.e. 50 Hz). In one revolution of the coil, current changes its polarity two times. This means the alternating current (AC) produced in our country changes polarity  $2 \times 50 = 100$  times in one second.

### Direct Current and Alternating Current

The electric current which always flows in the same direction is called **direct current or DC**. Thus, for DC, the positive and negative polarities are fixed. The current obtained from a battery or a cell is direct current.

The electric current which reverses its direction after a certain fixed interval of time is called **alternating current**. Thus, in AC, the positive and negative polarities are not fixed. The electricity supplied to our homes and industry is alternating current. The alternating current in India changes direction after every  $1/100$  second.



# Transformer

Transformer is a device used to convert low alternating voltage at higher current into high alternating voltage at lower current and vice versa. In other words, a transformer is an electrical device used either to raise or lower the voltage of an AC supply with a corresponding decrease or increase in current without affecting its frequency.

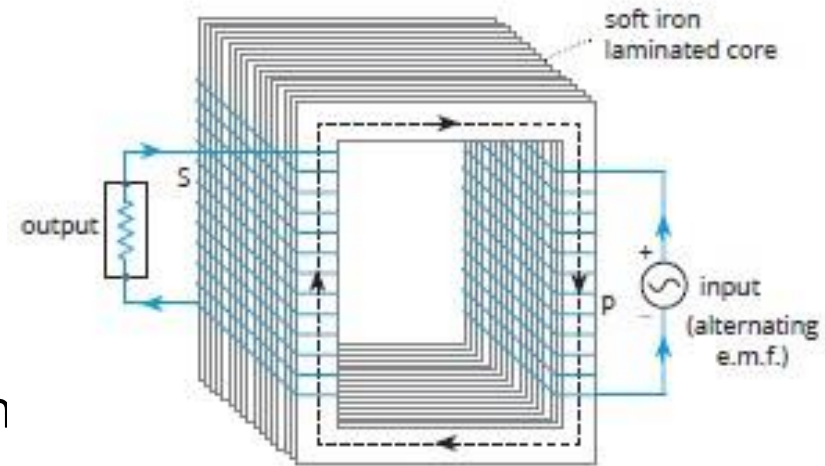

## Principle

It is based on the principle of mutual induction, i.e. whenever the current (or magnetic flux) through a coil changes, an e.m.f. is induced in the neighbouring coil.

## Types of transformers

There are two types of transformers:

1. Step-up transformer
2. Step-down transformer

**Note:** The differences between step-up transformer and step-down transformer are given in Table 10.2.



## SUMMARY

- 1. Magnetic effect of current:** An electric current produces magnetic effect in the space around the current-carrying conductor.
- 2. Rules for determining the direction of magnetic field:** a. Right-hand thumb rule b. Maxwell's corkscrew rule c. Ampere's swimming rule.
- 3. Solenoid:** A coil of insulated wire wound around a non-conducting hollow cylindrical core. When current is passed through a solenoid, it behaves like a magnet and develops a magnetic field around it.
- 4. Electromagnet:** An electromagnet is a solenoid with a soft iron core. It is usually made in the following two shapes a. I-shape b. U-shape.
- 5. Magnetic field of an electromagnet:** It can be increased by increasing the number of turns of the coil and the strength of the current through the coil.
- 6. Oersted's observation:** A current-carrying conductor when placed in a magnetic field moves in a direction perpendicular to the direction of the current as well as perpendicular to the direction of magnetic field.
- 7. Moving coil galvanometer:** A device to detect current in the circuit. Whenever a loop carrying current is placed in a magnetic field, it experiences a torque which tends to rotate it.



- 8. Electric motor:** It is a device which converts electrical energy into mechanical energy.
- 9. Power of electric motor:** It can be increased in the following ways by increasing **a.** the current flowing in the coil **b.** number of turns in the coil **c.** the area of cross section of the coil **d.** strength of radial magnetic field **e.** by laminating soft iron coil.
- 10. Faraday's observation:** An electric current could be produced in a circuit by changing magnetic field. This phenomenon is called electromagnetic induction. The current so produced is called induced current.
- 11. Generator:** A machine that produces electricity by converting mechanical energy into electrical energy. It works on the principle of electromagnetic induction.
- 12. Transformer:** It is a device used to convert low alternating voltage at higher current into high alternating voltage at lower current and vice versa. There are two types of transformers: **a.** Step-up transformer, **b.** Step-down transformer.
- 13. Energy loss:** The energy loss in a transformer takes place in the following ways: **a.** Copper losses **b.** Flux losses **c.** Eddy current losses **d.** Hysteresis losses **e.** Losses due to vibration of core



RATNA SAGAR

PRIMUS

BYWORD

E-LIVE

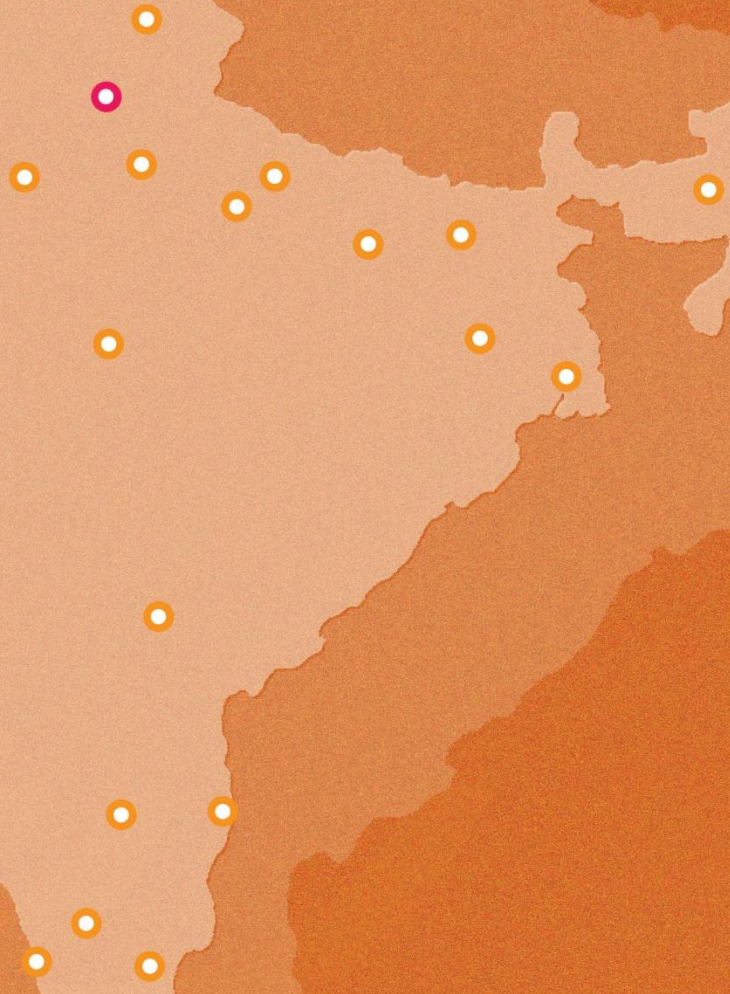
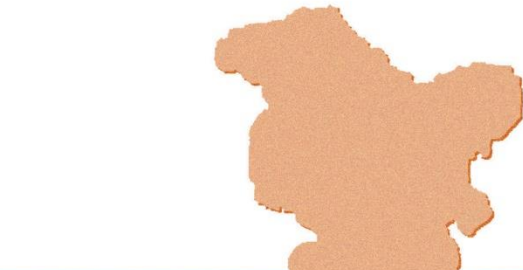

**THANK  
YOU**