



# Ratna Sagar

RATNA SAGAR

PRIMUS

BYWORD

E-LIVE

**Education, Our Mission**



# ICSE

# Living Science

# Physics

**Class 9**

**Chapter 1 Measurement and  
Experimentation**



As per the latest ICSE syllabus

9



# Living Science PHYSICS



Dhiren M Doshi

Rama Sagar

EDUCATION, OUR MISSION



## **LEARNING OBJECTIVES**

### **Measurement**

- ❖ Characteristics of a standard unit
- ❖ Old system of units

### **International System of Units-The SI Units**

- ❖ Base units
- ❖ Units of length
- ❖ Practical units for large distances
- ❖ Unit of mass
- ❖ Conventions in writing the SI units and their symbols

### **Measurement of Length**

- ❖ Least count of a measuring instrument

### **Vernier Callipers**

- ❖ Determination of zero error

### **Screw Gauge**

- ❖ Pitch, least count and zero error

### **Measurement of Time**

- ❖ Simple pendulum
- ❖ Time period of a simple pendulum
- ❖ Second's pendulum



## Measurement

Measurement is the comparison of unknown physical quantity with a known fixed unit quantity of the same nature.

To express the magnitude of a physical quantity, we should know two things:

1. The unit in which the quantity is measured.
2. The numeric value which expresses how many times the chosen unit is contained in the given physical quantity.

Magnitude of physical quantity = Numerical value of physical quantity  $\times$  Size of its unit

## Characteristics of a standard unit

The **unit** of any physical quantity must have the following features:

1. It should be of convenient size.
2. It should be well defined.
3. It should be easily reproducible, i.e. replicas of the unit should be available easily.
4. It should not change with time and place.
5. It should not change with the change in physical conditions, e.g. temperature, pressure, etc.
6. It should be easily available and accessible.



## Old system of units

Different units were assigned for mass and length in different countries. The common systems of units are given below:

- 1. CGS system:** It is the Gaussian system, which uses **centimetre, gram** and **second** as the three basic units of length, mass and time respectively.
- 2. FPS system:** It is the British engineering system of units, which uses **foot** as the unit of length, **pound** as the unit of mass and **second** as the unit of time.
- 3. MKS system:** It uses **metre** as the unit of length, **kilogram** as the unit of mass and **second** as the unit of time. When MKS system is extended to electricity, then with current as fundamental quantity, ampere (A) is taken as its unit. It is then called MKSA system.

However, the above mentioned systems (CGS, FPS, MKS) had their own **drawbacks** and **problem of coherence** and so, they are no longer used. Now, we use the SI system of units which are more scientific, convenient and have been accepted by all the countries for scientific work.

## International System of Units – The Si Units

To make measurements more scientific, convenient and uniform, the French Academy of Science in 1792 designed a metric system of measurement based on the decimal system.



In October 1960, the XIth General Conference on Weights and Measures adopted an international system of units called **SI units**. The name SI is an abbreviation of the “Système International d’Unités” in French, which means **International System of Units**.

## Base units

In SI system, there are seven base units corresponding to seven base physical quantities.

<b>Base quantity</b>	<b>SI unit</b>
<b>Name</b>	<b>Name</b> <b>Symbol</b>
1. Length	metre m
2. Mass	kilogram kg
3. Time	second s
4. Electric current	ampere A
5. Temperature	kelvin K
6. Luminous intensity	candela cd
7. Amount of substance (or quantity of matter)	mole mol



## Unit of Length

The SI unit of length is metre. One metre is defined as the length of the path travelled by light in vacuum during a time interval of  $1/299,792,458$  of a second.

### Practical units for large distances

In order to measure very large distances, we use the following three units.

1. **Astronomical Unit (AU)**: One astronomical unit is the mean distance between the centres of the earth and the sun, i.e.

$$1 \text{ astronomical unit (AU)} = 1.496 \times 10^{11} \text{ m}$$

2. **Light year (ly)**: One light year is the distance travelled by light in vacuum in one year, i.e.

$$1 \text{ light year} = \text{Speed of light in vacuum} \times \text{Time}$$

$$= 3 \times 10^8 \text{ m s}^{-1} \times 1 \text{ year}$$

$$= 3 \times 10^8 \text{ m s}^{-1} \times (365 \times 24 \times 60 \times 60) \text{ s}$$

$$= 9.46 \times 10^{15} \text{ m}$$

3. **Parsec**: One parsec is 3.26 times the light year,

$$= 3.26 \times (9.46 \times 10^{15} \text{ m})$$

$$1 \text{ parsec} = 3.08 \times 10^{16} \text{ m}$$



## Unit of Mass

The SI unit of mass is kilogram. One kilogram is defined as the mass equal to the mass of a standard platinum-iridium alloy cylinder (90% platinum and 10% iridium) kept at  $0^{\circ}\text{C}$  at the International Bureau of Weights and Measures at Sevres, near Paris in France.

## Unit of Time

The SI unit of time second. One second is the time needed for 9,192,631,770 vibrations of the radiation corresponding to the transition between the two hyperfine levels of the ground state of the two hyperfine levels of the ground state of the caesium–133 atom.

## Conventions in Writing the SI Units and their Symbols

The conventions (rules) that should be strictly followed while writing SI units are as follows:

1. In writing the value of a physical quantity, the number and the unit are separated by a space.
2. No space is to be given between number and  $^{\circ}\text{C}$ , degree, minute and second of a plane angle.



3. The symbols for the units of quantities, which are not named after scientists, are written in small letters.
4. The symbols for the units named after scientists are written with first letter of the name in capital letters.
5. To write the full name of a unit, the name is always written in small letters, even if it is the name of a scientist.
6. The symbol of a unit is never written in plural but when written in words, plural is used.
7. The symbol for a unit is not followed by a full stop until it appears at the end of a sentence.
8. In writing units for physical quantities, words and symbols should not be mixed.
9. A compound unit formed by multiplication of two or more units is written after leaving a space or a middle dot (.) between the symbols.
10. For a compound unit formed by division of units, the division is indicated by a horizontal line or a solidus (oblique stroke, /) or negative powers.
11. For numbers less than unity, zero should be inserted to the left of the decimal point.



## Measurement of Length

### Least count

The smallest value of a physical quantity which can be measured accurately with an instrument is called the least count (LC) of the measuring instrument. So, the least count of a metre scale is 1 mm.

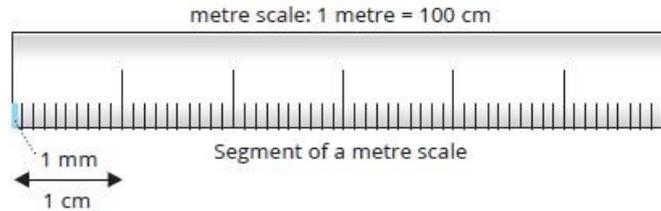

### Vernier callipers

It is a device used to measure lengths accurately up to  $1/10^{\text{th}}$  of a millimetre.

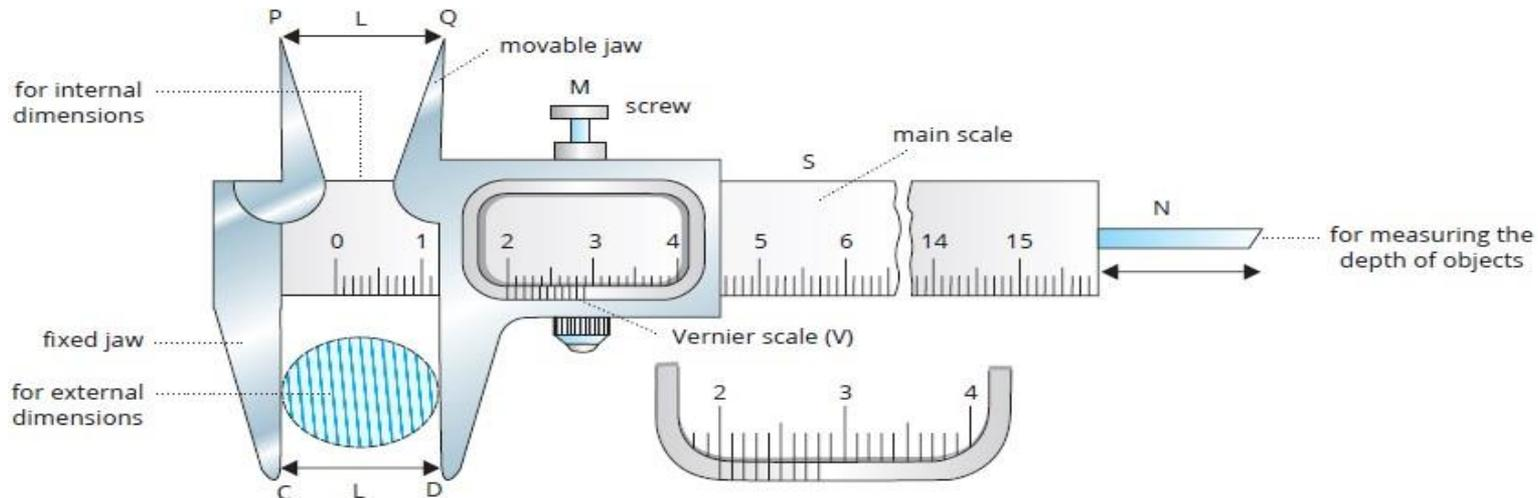



Vernier callipers comprise two scales, viz. the **Vernier scale (V)** and the **main scale (S)**. The main scale S is fixed but the Vernier scale V is movable. The Vernier scale slides along the main scale.

**Least count of Vernier callipers (Least Count) =**

Value of one main scale division/ Total number of divisions on the Vernier scale

**Determination of zero error**

Zero error can be of the following two kinds:

**1. Positive zero error:** If the zero mark of the Vernier scale lies towards the zero mark of the main scale when the jaws C and D are made to touch each other, the zero error is said to be positive.

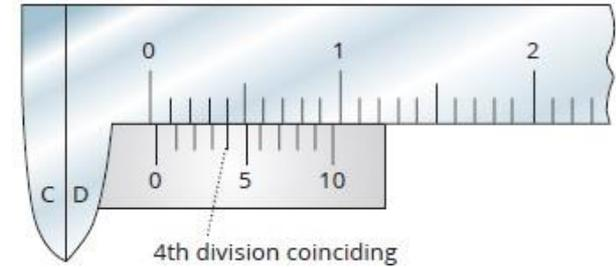

Positive zero error (+ 0.04 cm) and its correction

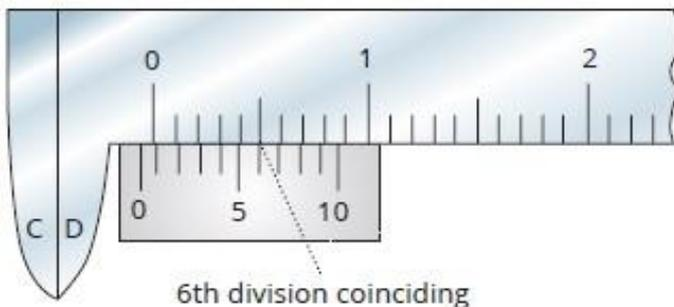

Negative zero error (− 0.04 cm) and its correction

**1. Negative zero error:** If the zero mark of the Vernier lies towards the left side of the zero of the main scale when the jaws C and D are made to touch each other, the zero error is said to be negative.



## Screw Gauge

It is a device used to measure accurately lengths up to  $1/100^{\text{th}}$  of a millimetre. As the least count of the screw is of the order of a micrometre ( $10^{-6}$  m), it is called **micrometre screw gauge**.

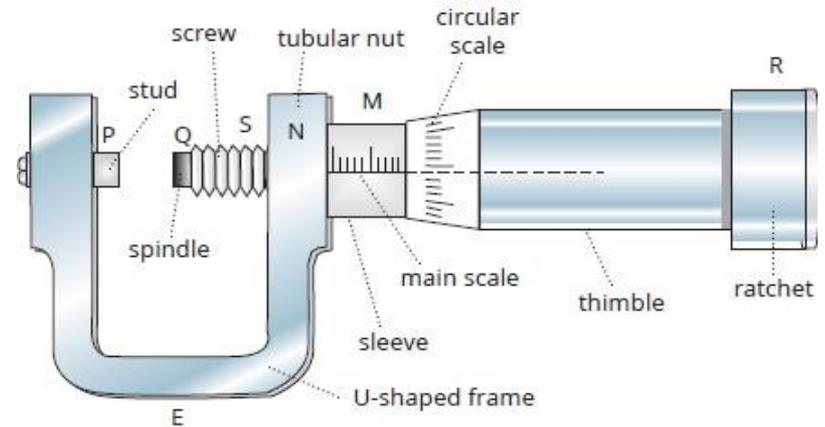

### The pitch of the screw gauge

The linear distance moved by the screw head during one complete rotation of the screw is called the pitch.

Pitch = Distance moved by the screw on the main scale/ Number of rotations

### The least count of the screw gauge

The least count of a screw gauge is the smallest length which can be measured accurately with it.

Least count of the screw gauge (L.C.) =

Pitch of the screw gauge/ Number of divisions on the circular scale

### Zero error

The zero error in case of a screw gauge may be **positive** zero error or **negative** zero error.



**No zero error:** In a perfect instrument, if on bringing the flat end Q of the screw in contact with stud P, the zero mark of the circular scale coincides with the zero mark on the line of graduation of the main scale, the instrument is said to be free from zero error

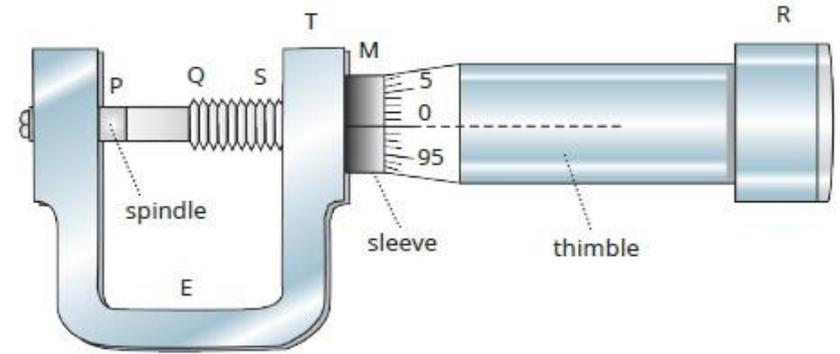

### Positive zero error and its correction

If the zero mark on the circular scale is below the line of graduation of the main scale, when the gap between stud P and flat end Q is reduced to zero (brought in contact with each other), the zero error is said to be positive.

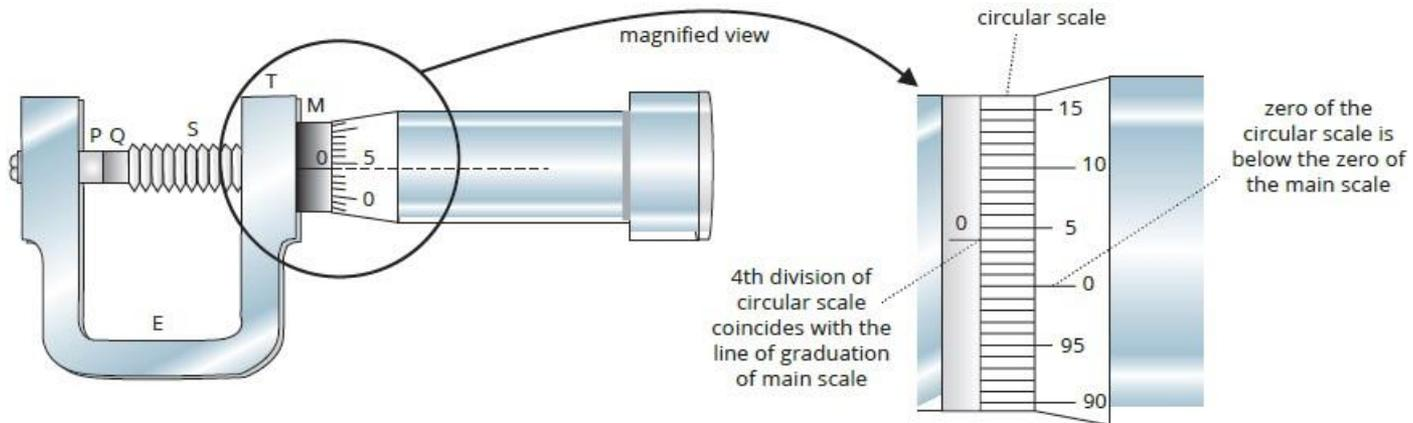



## Negative zero error and its correction

If the zero mark of the circular scale is above the line of graduation of the main scale, when the gap between stud P and flat end Q is reduced to zero (brought in contact with each other), the zero error is said to be negative.

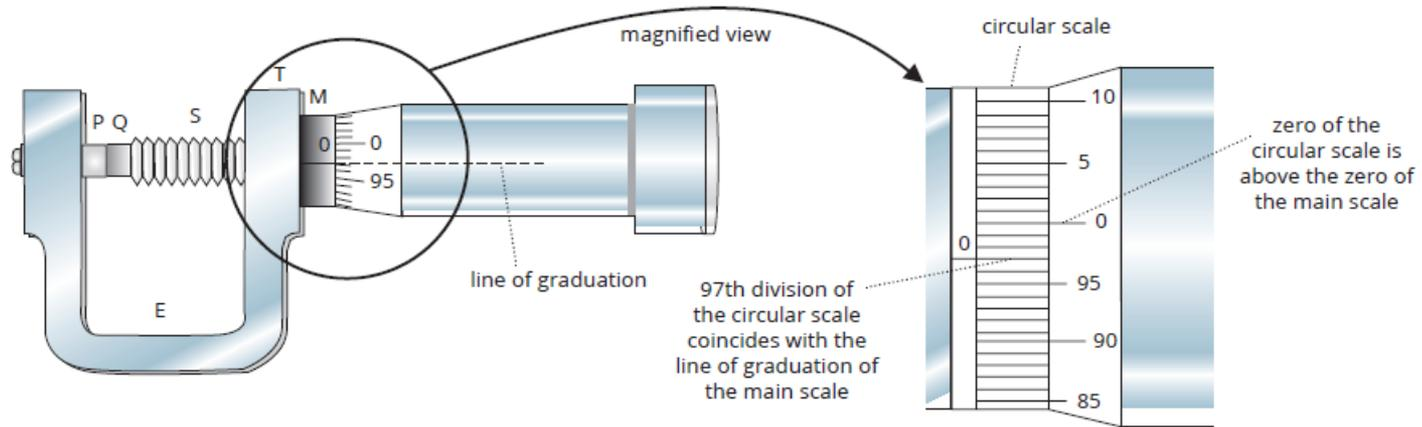

## Measurement of Time

Any phenomenon that repeats itself in a regular fashion serves as a clock for the measurement of time. Thus, clock is a device that counts the number of repetitions (including the fractions) of a periodic event.

## Simple Pendulum

A metallic bob suspended by means of a fine cotton thread (closest approximation to the ideal conditions) is used in the laboratory for measuring time interval.



The motion of a simple pendulum suspended from a rigid support is an oscillatory motion. If the bob of a pendulum is taken to one side and then left free, it performs oscillatory (or vibratory) motion.

## Important Terms

**1. Periodic motion:** A motion which repeats itself after equal intervals of time is called a periodic motion. The motion of a simple pendulum is an example of periodic motion.

**2. Oscillation or vibration:** A body is said to vibrate or oscillate when it moves to and fro (i.e. back and forth) about a fixed point which is called its mean position.

**3. One complete oscillation/vibration:** The motion of a vibrating body from its mean position to one extreme position, back to the other extreme position and then to mean position constitutes one vibration or oscillation.

**4. Time period:** The time taken by a vibrating body to complete one vibration or oscillation is called its time period. It is denoted by the symbol  $T$ . Its unit is **second (s)**.

**5. Frequency:** The number of complete vibrations made by a vibrating body in one second is called its frequency. It is denoted by  $n$  or  $f$ . The SI unit of frequency is hertz (Hz).

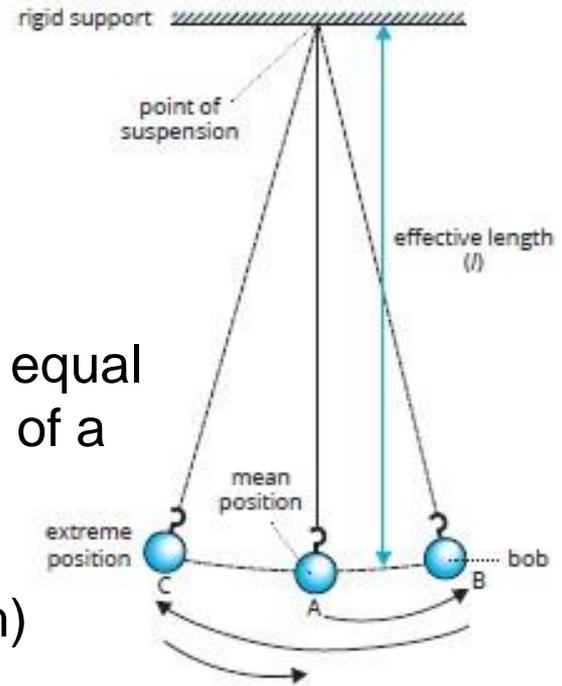



Frequency ( $f$ ) =  $1/\text{Time Period } (T)$

or  $T = 1/f$

**6. Amplitude:** The maximum displacement of a vibrating body on either side of its mean position is called its amplitude of vibration.

**7. Effective length of a pendulum:** The distance between the point of suspension and the centre of gravity of the bob is the effective length of a pendulum.

### Factors affecting the time period of a simple pendulum

1. The time period of a simple pendulum is directly proportional to the square root of its length, i.e.  $T \propto l$
2. The time period of a simple pendulum is inversely proportional to the square root of the acceleration due to gravity at that place, i.e.  $T \propto 1/\sqrt{g}$
3. The time period of a simple pendulum does not depend on the mass of the suspended body.
4. The time period of a simple pendulum does not depend on the material of the suspended body.
5. The time period of a simple pendulum does not depend upon the amplitude of the vibrations.



## Formula for the time period of a simple pendulum

The time period of a simple pendulum at a place depends on the length of the pendulum ( $l$ ) and the acceleration due to gravity ( $g$ ) at that place.

The formula for the time period ( $T$ ) of a simple pendulum is:

$$T = 2\pi \sqrt{l/g}$$

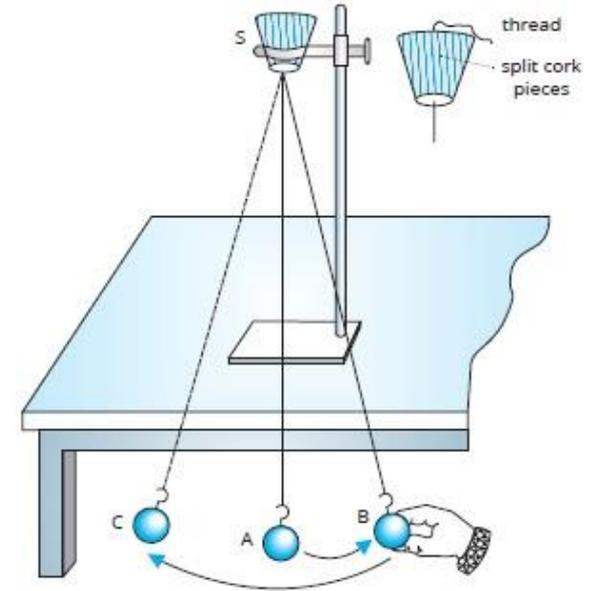

## Second's pendulum

A pendulum whose time period is two seconds is called a second's pendulum. It is used in pendulum clocks.

On the surface of the earth, a simple pendulum having a length of 99.2 cm will have a time period of 2 seconds.



## SUMMARY...

- 1. Measurement:** It is the comparison of unknown physical quantity with a known fixed unit quantity.
- 2. Fundamental units:** The units of measurement of length, mass and time are independent of each other, not definable in terms of other quantities. All other physical quantities can be obtained from them and so these three units are called fundamental or basic units.
- 3. Derived units:** The units of measurement of all other physical quantities which can be expressed in terms of the fundamental units (i.e. mass, length and time) are called derived units.
- 4. Metre:** One metre is the length of the path travelled by light in vacuum in  $1/299,792,458$  of a second. It is the SI unit of length.
- 5. Kilogram:** It is the SI unit of mass. One kilogram is the mass equal to the mass of a standard platinum–iridium alloy cylinder (90% platinum and 10% iridium) kept at  $0\text{ }^{\circ}\text{C}$  at the International Bureau of Weights and Measures at Sevres, near Paris, France.
- 6. Least count:** The smallest value of a physical quantity which can be measured accurately with an instrument is called the least count of the measuring instrument.



**7. Vernier callipers:** It is a device used to measure lengths accurately up to  $1/10$ th of a millimetre.

**8. Positive zero error of Vernier:** If the zero mark of the Vernier scale lies towards the right side of the zero mark of the main scale when both the jaws are made to touch each other, the zero error is said to be positive.

**9. Negative zero error of Vernier:** If the zero mark of the Vernier scale lies towards the left side of the zero mark of the main scale when both the jaws are made to touch each other, the zero error is said to be negative.

**10. Screw gauge:** It is a device used to measure lengths accurately up to  $1/100$ th of a millimetre.

**11. Positive zero error of a screw gauge:** If the zero mark on the circular scale is below the line of graduation of the main scale, when there is no gap between the jaws of the screw gauge, the zero error is said to be positive. In such a situation, the measured length will be more than the actual length.

**12. Negative zero error of a screw gauge:** If the zero mark on the circular scale is above the line of graduation of the main scale, when there is no gap between the jaws of the screw gauge, the zero error is said to be negative. In such a situation the measured length will be less than the actual length.



RATNA SAGAR

PRIMUS

BYWORD

E-LIVE

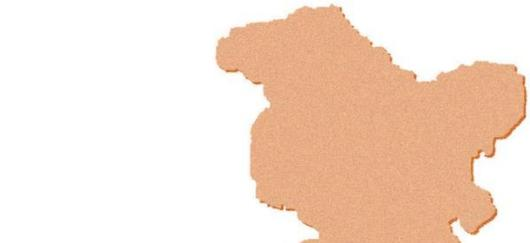

**THANK  
YOU**